

# Sigtronics SCI-S4 / SCI-S6 Installation Instructions

## INTRODUCTION

**ATTENTION INSTALLER:** To assure a trouble free installation, please read the entire instructions through once before beginning.

**WARNING:** This product can expose you to chemicals including Polyvinyl Chloride, which is known to the State of California to cause cancer, and Lead, which is known to the State of California to cause birth defects or other reproductive harm. For more information go to [www.P65Warnings.ca.gov](http://www.P65Warnings.ca.gov).

## SCI-S4 / SCI-S6 SYSTEM SPECIFICATIONS

**CONFIGURATION** - The Sigtronics SCI-S Intercom systems are specifically designed for permanent, panel mounted installation in aircraft. Up to four-position intercom is provided with the model SCI-S4. Model SCI-S6 handles up to six positions. "H" Model units for use in high noise aircraft.

**UPGRADE** - An SCI-S4 or SCI-S6 can replace an existing SPA-400, SPA-600, ST-400, or ST-600 installation. This requires minor mounting hole changes and minimal re-wiring.

**DUAL STEREO MUSIC INPUTS** - Both Crew and Passengers music inputs accept standard headphone (Walkman) or line level inputs. Automobile Speaker level outputs can be adapted for use with the SCI-S systems.

**COMPATIBILITY** - Sigtronics SCI-S intercoms have been designed to operate with all standard general aviation aircraft radios and headsets.

**SIZE:** Panel - 1" x 2½". Chassis - 1" high x 2½" wide x 6" deep. Can be mounted either horizontally or vertically in the aircraft panel.

**WEIGHT:** 7.3 ounces (SCI-S4 intercom unit with panel and knobs). Jacks and wiring harness weigh 8.9 ounces. 7.5 ounces (SCI-S6 intercom unit with panel and knobs). Jacks and wiring harness weigh 10.9 ounces.

**INPUT POWER:** 11VDC through 32VDC. Maximum current drain 0.2 Amp (SCI-S6)

**DISTORTION:** Less than 1% total harmonic distortion.

**WARRANTY:** The SCI-S units are constructed of high quality components and carry a five year parts and labor warranty.

**FAA TSO:** C-50c

**ENVIRONMENTAL:** DO-160D

**Environmental Category:**

A1D1XCAAS2MXXXXXXZBBBBXXXXXXXXXXXX



## Hardware Supplied

Besides the intercom unit and instructions, each SCI-S system comes with the following hardware:

	SCI-S4	SCI-S6
Headphone Output Jacks - Accept standard 0.250" aircraft stereo headphone plugs	4	6
Microphone Input Jacks - Accept standard 0.206" aircraft microphone plugs. (U93 plug compatible jacks can be used in place of the jacks provided - mono installations only)	4	6
Mic Jack Insulating Washers, Flat	4	6
Mic Jack Insulating Washers, Shoulder	4	6
Intercom Panel - lettered on both sides.	1	1
Intercom Control Knobs	4	4
Mounting Screws 4-40 x 1/2	2	2
Drill Template - Adhesive backed hole size pattern for drilling aircraft panel	1	1
Aircraft /IntercomInterface Cable (4 feet long)	1	1
Headphone/Music Interface Cable (4 feet long)	1	1
Stereo music input jacks 3.5mm	2	2



**Specialists in "SOUND" Management**

178 East Arrow Highway, San Dimas, CA 91773 ( 909 ) 305-9399

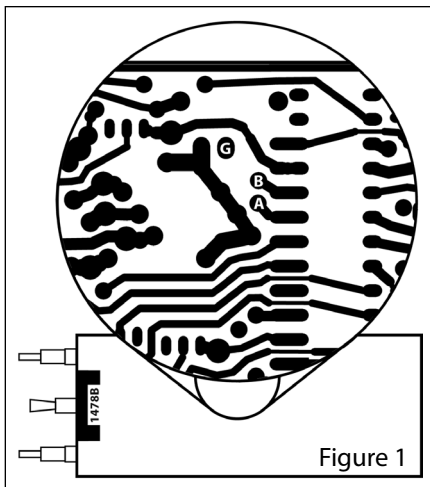

Figure 1

## INTERCOM OPTIONS

The SCI-S intercoms have two options that can be enabled if desired. Installing small jumper wires on the solder side of the circuit board enables these options. As such they have to be installed before the unit is installed into the aircraft.

**OPTION "A" - FULL MUSIC MUTE DURING ICS** - When listening to music and someone speaks on the intercom the default factory operation is to partially mute the music so you can hear the conversation. If you prefer however, the music can be completely muted during intercom if you enable this option. Note - during radio transmission and reception, the music will always be fully muted regardless if this option is selected or not. This is for communication safety reasons.

**OPTION "B" - PILOT TRANSMIT PRIORITY** - If the pilot and the copilot key at the same time (not a common occurrence) the default operation is that both microphones will go out the aircraft radio to the tower. If you prefer only the pilot's microphone active when both press their PTT's simultaneously then enable this option. Note - if only one of the pilots presses his PTT only his mic will go out over the radio regardless if this option is selected or not.

To enable either or both of these options, remove the four screws on the bottom of the SCI-S unit and remove the cover. Refer to Figure 1. To enable option A (full music mute during ICS), solder a small jumper from the pad labeled "A" to the pad labeled "G". To enable option B (pilot transmit priority) solder a small jumper between pad "B" and pad "G". Replace the cover and the four screws and tighten. Removing these jumpers will deactivate the options.

## CHASSIS INSTALLATION

To upgrade an existing SPA-400 installation to an SCI-S4 or a SPA-600 to an SCI-S6 skip to the "UPGRADING A SPA INSTALLATION TO A SCI-S" section on page 4. For a completely new intercom installation, continue below.

## UNIT PLACEMENT

The SCI-S unit has been designed to mount either horizontally or vertically in your aircraft panel. The location selected for the SCI-S unit requires a minimum front panel area of 2½" by 1". Depth required behind panel is 6" plus cable access.

**CAUTION:** Move the aircraft flight controls through the limits of travel while observing the selected area and making sure that the rear of the intercom and cable will not interfere with any aircraft control components.

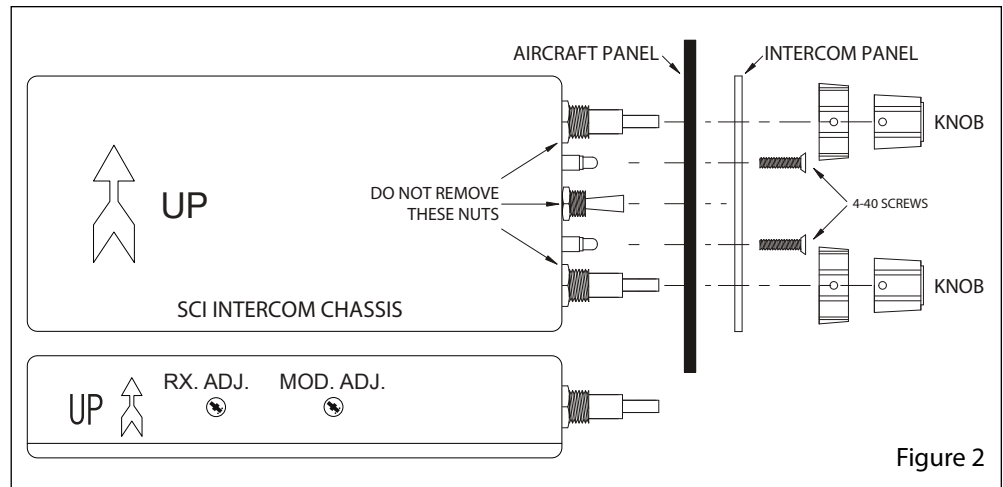

Figure 2

## Panel Preparation

1. Position the adhesive drill template on the aircraft panel in the selected area.
2. Center punch each hole at the cross lines. (Five holes are in a straight line and equally spaced 0.4" apart. The two Squelch Indicator Light holes are 0.8" apart).
3. Drill ⅛" pilot holes in all seven places.
4. Enlarge two holes to ⅜", one hole to ⅞", and two holes to ⅜" per the template.

## MOUNTING CHASSIS (See Figure 2)

1. Remove the knobs from the Volume and Squelch controls using a 0.050" Allen wrench. **NOTE:** DO NOT REMOVE the nuts from the Volume/Squelch, or ALL / ISO / CREW controls.
2. Insert the SCI-S unit from the rear of the aircraft panel with the appropriate arrow on the unit chassis pointing upwards. Make sure the squelch indicator lights have unrestricted movement through aircraft panel.
3. Install the printed SCI-S panel and lightly thread the two 4-40 screws through the holes in intercom panel. The nuts on the Volume/Squelch and ALL / ISO / CREW controls will fit inside the ⅜" and ⅞" diameter holes.
4. Tighten the two screws.
5. Install the knobs on the Volume (VOL) and Squelch (SQ) control shafts and tighten the Allen screws.

## MOUNTING HEADPHONE AND MICROPHONE JACKS (See Figure 3)

1. Locate the mounting areas. (One mic and one headphone jack required for each headset). Again, make sure that the jacks will not interfere

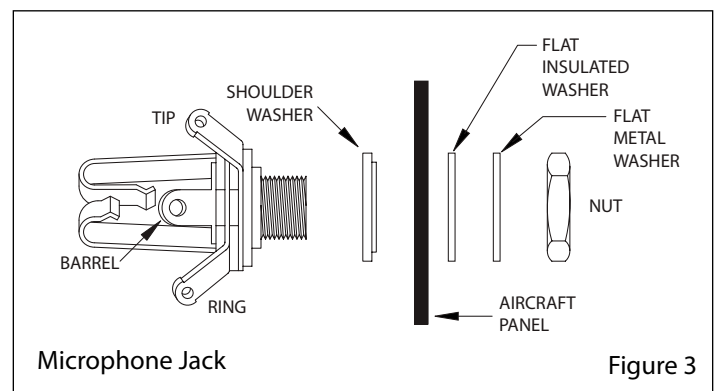
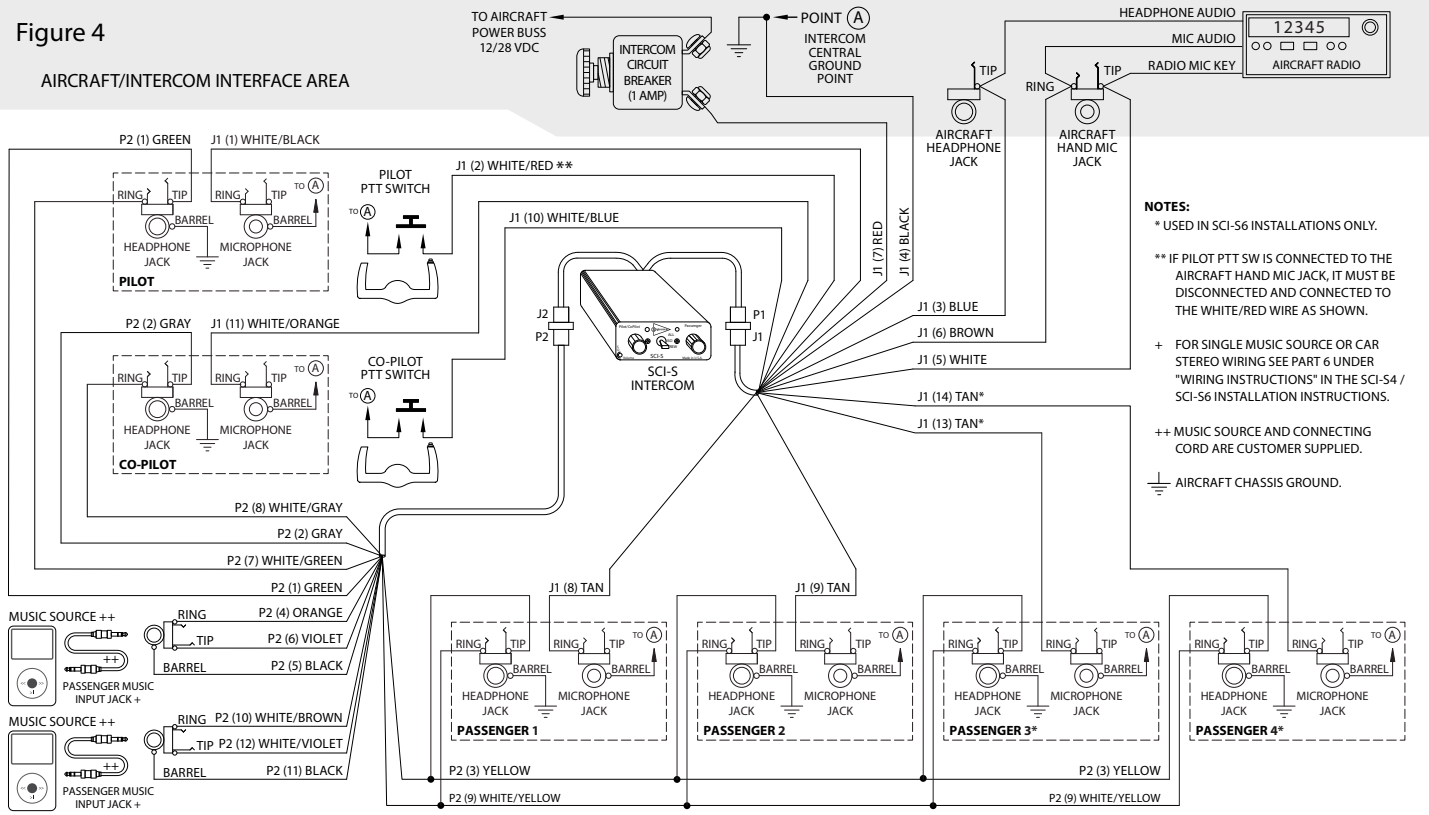

Figure 3

Figure 4

AIRCRAFT/INTERCOM INTERFACE AREA



**NOTES:**  
 \* USED IN SCI-S6 INSTALLATIONS ONLY.  
 \*\* IF PILOT PTT SW IS CONNECTED TO THE AIRCRAFT HAND MIC JACK, IT MUST BE DISCONNECTED AND CONNECTED TO THE WHITE/RED WIRE AS SHOWN.  
 + FOR SINGLE MUSIC SOURCE OR CAR STEREO WIRING SEE PART 6 UNDER "WIRING INSTRUCTIONS" IN THE SCI-S4 / SCI-S6 INSTALLATION INSTRUCTIONS.  
 ++ MUSIC SOURCE AND CONNECTING CORD ARE CUSTOMER SUPPLIED.  
 ⚡ AIRCRAFT CHASSIS GROUND.

SCI-S4 / SCI-S6 INSTALLATION WIRING DIAGRAM

TABLE 1 - P1 / J1 - See Wiring Instructions

PIN	WIRE COLOR	FUNCTION	CONNECT TO
1	White / Black	Pilot Mic Input	Ring Terminal of Pilot Mic Jack
2	White / Red	Pilot Transmit Switch Input	Pilot Transmit Switch (PTT) (Switch to Ground to Transmit)
3	Blue *1	Radio Headphone Input	Radio Headphone Output
4	Black *2	Intercom Central Grounding Point "A"	Aircraft Chassis Ground
5	White	Radio Transmit Key Output	Tip Terminal of Aircraft Hand Mic Jack, or Key Input of Aircraft Radio or Audio Panel
6	Brown	Transmit Mic Audio Output	Ring Terminal of Aircraft Hand Mic Jack or Mic Input of Aircraft Radio or Audio Panel
7	Red *3	12 through 28 VDC Power Input	Intercom Circuit Breaker
8	Tan *4	Passenger #1 Mic Input	Ring Terminal of Passenger #1 Intercom Mic Jack
9	Tan *4	Passenger #2 Mic Input	Ring Terminal of Passenger #2 Intercom Mic Jack
10	White / Blue	Co-Pilot Transmit Switch Input	Co-Pilot Transmit Switch (PTT) (Switch to Ground to Transmit)
11	White / Orange	Co-Pilot Mic Input	Ring Terminal of Co-Pilot Mic Jack
12	N/C	None	No Connection
13	Tan *5	Passenger #3 Mic Input	Ring Terminal of Passenger #3 Intercom Mic Jack
14	Tan *5	Passenger #4 Mic Input	Ring Terminal of Passenger #4 Intercom Mic Jack
15	N/C	None	No Connection

TABLE 2 - J2 / P2 - See Wiring Instructions

PIN	WIRE COLOR	FUNCTION	CONNECT TO
1	Green *7	Pilot Intercom Right Headphone Output	Tip Terminal of Pilot Headphone Jack
2	Grey *7	Co-Pilot Intercom Right Headphone Output	Tip Terminal of Co-Pilot Headphone Jack
3	Yellow *7	Passenger Intercom Right Headphone Output	Tip Terminal of Passenger Headphone Jacks
4	Orange *6	Crew Music Input Left Channel	Left Crew Music Source Headphone / Line output
5	Black *6	Crew Music Input Common	Crew Music Source Common Headphone / Line Output
6	Violet *6	Crew Music Input Right Channel	Right Crew Music Source Headphone / Line output
7	White / Green *7	Pilot Intercom Left Headphone Output	Ring Terminal of Pilot Headphone Jack
8	White / Grey *7	Co-Pilot Intercom Left Headphone Output	Ring Terminal of Co-Pilot Headphone Jack
9	White / Yellow *7	Passenger Intercom Left Headphone Output	Ring Terminal of Passenger Headphone Jacks
10	White / Brown *6	Passenger Music Input Left Channel	Left Passenger Music Source Headphone / Line output
11	Black *6	Passenger Music Input Common	Passenger Music Source Headphone / Line Common Output
12	White / Violet *6	Passenger Music Input Right Channel	Right Passenger Music Source Headphone / Line output

with any aircraft control components. (Note that the jack contacts will expand when a plug is inserted into the jack.)

2. Drill  $\frac{3}{8}$ " diameter holes for headphone jacks and install.
3. Drill  $\frac{1}{2}$ " diameter holes for the mic jacks and install with the insulating washers supplied. (See Figure 3)

**Note:** If the aircraft already has pilot headset jacks, the location can be used for intercom with the following changes. The mic jack must be re-wired as follows:

1. Remove any existing wires from the tip, ring, and barrel connections.
2. Connect the intercom white/black wire to the ring terminal.
3. Connect one end of a wire to the barrel terminal of the mic jack and connect the other end to Point "A".
4. Install insulating washers as necessary if the barrel of the mic jack is mounted in metal.

For the headphone jack, replace the mono headphone jack with the stereo headphone jack. Connect the green wire (P2 pin 1) to the tip connection. Connect the white/green wire (P2 pin 7) to the ring connection.

## WIRING INSTRUCTIONS

Connections should be made as shown in Figure 4 and indicated in Tables 1 and 2. If longer wire lengths are required, use a good quality hook-up wire - 22 gauge or larger. Although not necessary, shielded audio wire can be used if desired. This can simplify the wiring process.

1. The blue wire from Pin 3 must be connected to the aircraft radio headphone output - NOT the speaker output.
2. Connect all intercom mic jack grounds to a single aircraft chassis ground point - Point "A" - as shown in Figure 4. (Use the black washers supplied to insulate the intercom mic jacks from aircraft chassis ground). Note this intercom central grounding point is used to eliminate any unwanted electrical noises, such as alternator whine or strobe noise, from being induced into the intercom system through the grounds. All intercom mic jack barrels must be insulated from ground where they are mounted and connected back to Point "A" on their own individual ground wire. Similarly, both intercom ground wires (J1 pin 4) and the push-to-transmit switch grounds must also be connected back to Point "A". It is not necessary, however, to connect the headphone jack barrels to Point "A". They can either be grounded where they are mounted or some place nearby.

3. The red wire may be connected to either 12V (14V) or 24V (28V) power source. No switching or adjustments are required to operate from either source.

4. Tan wires (J1 pins 8, 9, 13, 14) are only used on installations that require extra intercom positions.

5. Tan wires pins 13 and 14 are provided on SCI-S6 units only.

6. The SCI-S system provides two separate music inputs - one for the crew and the other for the passengers. These music inputs accept Headphone (Walkman) or Line level music sources. The wiring diagram shows how to wire the SCI-S for dual music inputs for use with por-

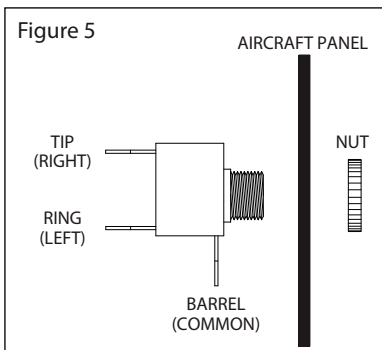
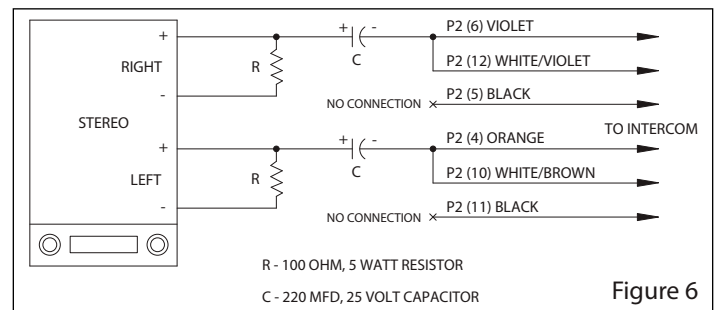

table stereo music sources. Two small stereo input jacks are supplied for this purpose. Connect the Orange, Violet, and Black wires to one jack as shown in Figure 4. Identify the jack terminals using Figure 5. Connect the White/Brown, White/Violet, and Black wires to the second jack. Drill a  $\frac{1}{4}$ " hole for each jack and mount on the aircraft panel. To use, connect an adapter cable between the music input jack and the output of the portable stereo. Suitable cables are available at your local Stereo or electronics store as well as from Sigtronics.

If only a single portable music source is to be used there are two different methods this can be done. The first way and most flexible is to wire just like the wiring drawing and use a mini-jack "Y" or splitter (also available at your local Stereo or electronics store) and dual cables to go from one stereo into both crew and passenger input jacks. The second way is to use just one of the supplied music input jacks and connect both inputs to it. Do this by connecting both the Orange and the White/Brown wire to the TIP terminal, the Violet and White/Violet to the RING, and both Blacks to the BARREL.

Speaker level output car stereo music sources can also be used with the SCI-S system. A Floating Ground Adapter or a four wire to three wire converter will have to be used between the Stereo and the SCI-S music inputs. Figure 6 shows such an adapter and how it is wired into the SCI-S.



7. The Sigtronics SCI-S system can be installed as shown for use with Stereo headsets. Alternatively, monaural general aviation type headsets can be used. To use monaural headsets follow the installation instructions as normal except for the wiring of the stereo headphone jacks. Use the stereo headphone jacks supplied with the Sigtronics SCI-S but leave the "RING" connections open. Instead connect both headphone wires to the "TIP" of the respective jacks. Connect both the WHITE/GREEN and GREEN on to the TIP of the pilot jack, WHITE/GREY and GREY on the copilot's and WHITE/YELLOW and YELLOW on the passengers.

8. Make sure any unused wires are properly insulated and kept from shorting to any other wires or aircraft ground. Skip down to the "INSTALLATION CHECK OUT AND ADJUSTMENT" section on page 5.

## UPGRADING A SPA INSTALLATION TO A SCI-S

### Chassis Mounting

The SCI-S4 is specifically designed to easily replace a SPA-400. Similarly, the SCI-S6 can replace a SPA-600. The panels are exactly the same dimensions (1" x 2 $\frac{1}{2}$ " ), however the SCI-S units are  $\frac{1}{4}$ " longer than the SPA units. You will have to make sure that you have the extra depth required behind your panel. Five mounting holes are exactly in the same positions. The center hole will have to be enlarged from  $\frac{1}{4}$ " to  $\frac{3}{16}$ ", the two outer holes will have to be enlarged to  $\frac{3}{16}$ ", and two additional holes drilled to  $\frac{3}{16}$ " (As per template).

To upgrade, first remove the SPA unit from the aircraft panel. This is done by unscrewing the two Phillips head screws and the nut on the ON / OFF switch. Remove the printed SPA panel. Pull the SPA unit out and unplug the white connector from the wiring harness. Next, drill the center hole in the aircraft panel out to 7/16". Then drill the two outer holes to 9/16", then use template to mark the position of the final two holes and drill. Finally mount the SCI-S chassis (see Figure 2):

1. Remove the knobs from the Volume and Squelch controls using a 0.050" Allen wrench. **NOTE: DO NOT REMOVE** the nuts from the Volume/Squelch (VOL/ SQ) or ALL / ISO / CREW controls.
2. Insert the SCI-S unit from the rear of the aircraft panel with the appropriate arrow on the unit chassis pointing upwards. The squelch indicator lights (LED's) should easily fit through their respective holes.
3. Install the printed SCI-S panel and lightly thread the two 4-40 screws through the holes in intercom panel. The nuts on the Volume/Squelch and ALL / ISO / CREW controls should fit inside the aircraft panel holes.
4. Tighten the two screws. Make sure LED's have unrestricted movement in aircraft panel holes.
5. Put the knobs on the Volume and Squelch control shafts and tighten the Allen screws.

### Wiring Change

The wiring changes to an existing SPA installation are as follows. Re-wire the pilot, co-pilot, and passenger(s) headphone lines. You will not need the 4-foot Intercom/Aircraft interface cable (12 or 15 pin) that comes with the SCI-S system. You will use the SPA harness already in the aircraft and the 4-foot Headphone/Music interface cable (12 pin).

In a SPA installation, the tip terminals of the pilot, co-pilot, and passenger headphone jacks are wired to the blue wire (pin 3). They need

to be disconnected from there, the mono headphone jacks need to be replaced with the supplied stereo headphone jacks and connected to their respective pins on the Headphone/Music interface harness. (See Figure 4 on page 3) Make sure that the blue wire (pin 3) is still connected to the tip of the radio headphone line.

### INSTALLATION CHECK-OUT AND ADJUSTMENTS

After the unit is installed, again check that the SCI-S unit chassis, jacks, and wiring harness are clear of all aircraft operating controls and cause no interference with them. Next, to check out the SCI-S unit installation plug in all the headset mic and phone plugs into the respective intercom jacks. Put on the pilot's headset and position the boom mic close to the mouth, as is the practice with a hand-held mic. Voice clarity is best when the mic is at one side of the mouth and 1/4" from the lips.

To assure that the aircraft radios, pilot's headset, and PTT switch are connected and functioning properly, remove power to the SCI-S by pulling intercom circuit breaker. If applicable, set the aircraft audio panel to "Headphone" position. Then turn on the aircraft radio(s) as usual, and verify that the pilot can hear the radios and can transmit using his push-to-transmit switch and headset. Aircraft radio(s) and audio panel should operate exactly as they did before the SCI-S system was installed. Aircraft radio reception should not be heard in the co-pilot or passenger headsets. There should be no intercom between headsets without power applied to the SCI-S unit.

Next restore power to the SCI-S unit. Switch ALL / ISO / CREW control to the "ALL" position. Set the SCI-S volume controls to mid-position. Set both SCI-S squelch controls fully clockwise. Pilot can operate the aircraft radio(s). In this mode all headsets on the intercom will hear the aircraft radio(s).

SCI-S4 / SCI-S6 MODE SELECTION TABLE			
MODE	PILOT HEARS	CO-PILOT HEARS	PASSENGERS HEAR
ALL	ATC, Crew ICS, Pass ICS, Crew Music	ATC, Crew ICS, Pass ICS, Crew Music	ATC, Crew ICS, Pass ICS, Pass Music
ISO	ATC	Co-pilot ICS, Pass ICS, Crew Music	Co-pilot ICS, Pass ICS, Pass Music
CREW	ATC, Crew ICS, Crew Music	ATC, Crew ICS, Crew Music	Pass ICS, Pass Music

SCI-S4 / SCI-S6 AUDIO PRIORITY TABLE			
AUDIO	MODE – ALL AUDIO IS MUTED BY:	MODE – ISO AUDIO IS MUTED BY:	MODE – CREW AUDIO IS MUTED BY:
PILOT MIC	Co-pilot PTT*	Never Muted	Co-pilot PTT*
CO-PILOT MIC	Pilot PTT*	Co-pilot PTT	Pilot PTT*
PASSENGER MICS	Pilot PTT or Co-pilot PTT	Never Muted	Never Muted
PILOT ATC RADIO	Pilot PTT or Co-pilot PTT	Never Muted	Pilot PTT or Co-pilot PTT
CO-PILOT ATC RADIO	Pilot PTT or Co-pilot PTT	Always Muted	Pilot PTT or Co-pilot PTT
PASSENGER ATC RADIO	Pilot PTT or Co-pilot PTT	Always Muted	Always Muted
CREW MUSIC **	Pilot PTT, Co-pilot PTT, ATC, Crew ICS, or Pass ICS	Co-pilot PTT, Co-pilot ICS, or Pass ICS	Pilot PTT, Co-pilot PTT, ATC, or Crew ICS
PASS MUSIC **	Pilot PTT, Co-pilot PTT, ATC, Crew ICS, or Pass ICS	Co-pilot PTT, Co-pilot ICS, or Pass ICS	Passenger ICS

**NOTES:** **ATC** - Aircraft VHF Radio. **Crew** - Pilot and Co-pilot. **ICS** - Intercom Audio. **PTT** - Push-To-Transmit Switch.

\* Pilot Mic will always go out over the VHF radio when his PTT is keyed. Co-pilot Mic will also go out when both PTT's are pressed, unless the "Pilot Transmit Priority" option is enabled.

\*\* Music sources will partial mute on ICS, unless the "Full Music Mute During ICS" option is enabled.

## Stereo Music Systems

It may be necessary at this time to adjust the SCI-S unit mic output to the aircraft radios. A small adjustable potentiometer is provided inside the unit for this purpose. It is accessible through a hole in the side of the SCI-S chassis. It is marked "Mod. Adj.," and can be adjusted with a small blade screwdriver (See Figure 2). In the event of over-modulation (garbled) or reports of weak transmissions over the aircraft radio, an appropriate adjustment can be made. Clockwise rotation increases the output level to the aircraft radio mic input. Counter-clockwise rotation decreases modulation level. This adjustment sometimes needs to be made after the initial installation of the intercom or if a new radio is installed. (The output is set for unity gain at Sigtronics).

It may also be necessary to adjust the SCI-S unit radio receive input from the aircraft radio. A small adjustable potentiometer is provided inside the unit for this purpose. It is accessible through a hole in the side of the SCI-S chassis. It is marked "RX Adj.," and can be adjusted with a small blade screwdriver (See Figure 2). In the event of low aircraft radio volume in the "ALL" or "CREW" mode relative to "ISO" mode, an appropriate adjustment can be made. Clockwise rotation increases the input level to the SCI-S radio receive input. Counter-clockwise rotation decreases input level. This adjustment sometimes needs to be made after the initial installation of the intercom or if a new radio is installed that has a low output impedance or low output power. The adjustment is best made with the pilot and co-pilot headsets plugged in. (The input is set full CCW which is unity gain for 500Ω radios).

You are now ready to check for proper wiring of the music sources. First, make sure both squelch lights are off and intercom is in ALL mode. Turn on the crew music source and listen for music through pilot and co-pilot headsets. There should be music. Then switch to CREW mode. There should also be music in both pilots' headsets. Similarly, turn on the passenger music source. There should be music in the passenger headsets.

If everything checks out, refer to the MODE SELECTION and AUDIO PRIORITY TABLES as well as the separate SCI-S4/SCI-S6 OPERATING INSTRUCTIONS sheet for proper use and other operating modes of the Sigtronics SCI-S intercom system. If something does not work as described, carefully go over the intercom wiring again. If something is still not right or you have any questions regarding the installation and operation of the Sigtronics SCI-S intercom or any other Sigtronics product feel free to contact us directly or email us at tech@sigtronics.com. Technicians are available Monday through Friday 8 am to 4:30 PM Pacific time.

This concludes the installation check-out.

Most automotive stereo units operate from 12V-14V sources. If you want to use these in a 28 volt aircraft do not connect them directly to power. Regulators or converters are available to permit operation from 24V-28V sources.

Some AM-FM music receivers are capable of causing interference with aircraft COM and NAV receivers. The aircraft panel should be placarded accordingly. Most player only units (cassette or CD) do not cause interference with aircraft receivers.

Line level stereo music outputs can also be used into the SCI-S system. Some line level outputs however, are a fixed level and are not adjusted by the devices volume control. If this is the case you will not be able to change the volume of the music you hear in the headsets. Headphone level or Speaker level outputs would be better in this case.

## Stereo Headsets

The Sigtronics SCI-S systems are designed for use with general aviation Stereo headsets with high impedance speakers (300 to 600 ohms). Headsets with low impedance (less than 100 ohms) speakers should not be used with SCI-S systems without modification. Contact Sigtronics for details. In general, headsets with speakers of high and low impedance and/or unmatched audio efficiencies should not be used together without modifications.

Sigtronics stereo headsets are specifically designed for the aircraft high noise environment and give excellent noise attenuation. They also provide full frequency response stereo for maximum enjoyment. They are compatible with aircraft mic circuits and can be used as general aviation headsets in aircraft that are not equipped with stereo headphone jacks. This is because they include a switch to change from "Stereo" to "Monaural". No adapters required.

**NOTE:** General aviation headset (monaural) phone plugs should not be plugged into SCI-S stereo phone jacks. A monaural plug in a stereo jack shorts out one of the audio channels. This will not damage the SCI-S system in any way but will cause reduced performance. General aviation headsets may be used only if one of the following three changes are made:

1. Monaural to stereo adapters are used on the headset head-phone plugs. (Only monaural music will be heard.)
2. The general aviation headsets are re-wired for stereo reception.
3. Install the Sigtronics SCI-S system for monaural operation. See note 6 on page 4 in the "WIRING INSTRUCTIONS" section.

See the separate SCI-S4/SCI-S6 OPERATING INSTRUCTIONS sheet for complete operation information.

Sigtronics Corporation  
178 East Arrow Highway  
San Dimas, Ca 91773  
909) 305-9399  
www.sigtronics.com

