

# GMA 245/245R

## Installation Manual

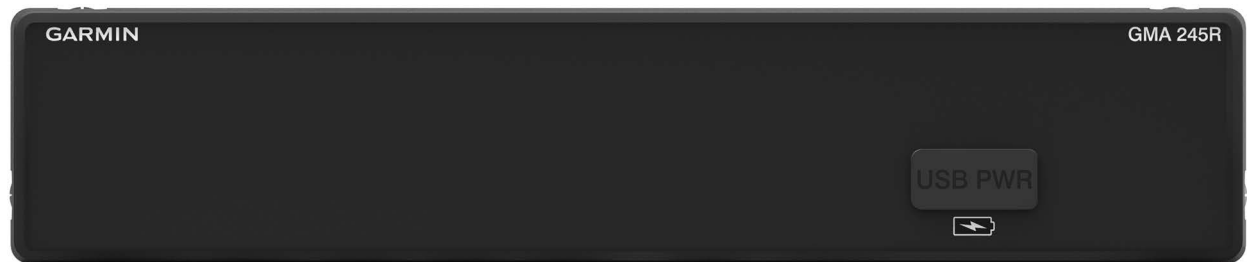

© 2023  
Garmin Ltd. or its subsidiaries  
All Rights Reserved

Except as expressly provided herein, no part of this manual may be reproduced, copied, transmitted, disseminated, downloaded or stored in any storage medium, for any purpose without the express prior written consent of Garmin. Garmin hereby grants permission to download a single copy of this manual and of any revision to this manual onto a hard drive or other electronic storage medium to be viewed and to print one copy of this manual or of any revision hereto, provided that such electronic or printed copy of this manual or revision must contain the complete text of this copyright notice and provided further that any unauthorized commercial distribution of this manual or any revision hereto is strictly prohibited.

Garmin International, Inc.  
1200 E. 151st Street  
Olathe, KS 66062 USA  
Aviation Panel-Mount Technical Support Line (Toll Free) 1.888.606.5482

Garmin (Europe) Ltd.  
Liberty House, Hounslow Business Park  
Southampton, Hampshire SO40 9LR U.K.

Garmin Würzburg GmbH  
Beethovenstrasse 1a  
97080 Würzburg, Germany

Garmin aviation support and warranty information is available at [garmin.com/aviationwarranty](https://www.garmin.com/aviationwarranty).

### **RECORD OF REVISIONS**

<b>Revision</b>	<b>Revision Date</b>	<b>Description</b>
8	02/22/19	Added GMA 245R MKR unit info
9	07/01/19	Updated interconnect drawings
10	05/17/21	Updated accessories info
11	06/07/23	Added new unit part numbers
12	07/06/23	Updated Transmitter Grant of Equipment Authorization info

### **CURRENT REVISION DESCRIPTION**

<b>Revision</b>	<b>Page Number</b>	<b>Section Number</b>	<b>Description of Change</b>
12	iii, iv	Front Section	Updated Transmitter Grant of Equipment Authorization info

### **INFORMATION SUBJECT TO EXPORT CONTROL LAWS**

This document may contain information which is subject to the Export Administration Regulations ("EAR") issued by the United States Department of Commerce (15 CFR, Chapter VII, Subchapter C) and which may not be exported, released, or disclosed to foreign nationals inside or outside of the United States without first obtaining an export license. The preceding statement is required to be included on any and all reproductions in whole or in part of this manual.

## DEFINITIONS OF WARNINGS, CAUTIONS, AND NOTES



### **WARNING**

*A warning means injury or death is possible if the instructions are not obeyed.*



### **CAUTION**

*A caution means that damage to the equipment is possible.*



### **NOTE**

*A note gives more information.*



### **WARNING**

*This product, its packaging, and its components contain chemicals known to the State of California to cause cancer, birth defects, or reproductive harm. This Notice is being provided in accordance with California's Proposition 65. If you have any questions or would like additional information, please refer to our web site at [www.garmin.com/prop65](http://www.garmin.com/prop65).*



### **NOTE**

*Throughout this document, the use of GMA 245 refers to both the GMA 245 and the GMA 245R unless specifically noted otherwise.*



### **NOTE**

*The Bluetooth® word mark and logos are registered trademarks owned by Bluetooth SIG, Inc. and any use of such marks by Garmin is under license.*

## SOFTWARE LICENSE AGREEMENT

BY USING THE DEVICE, COMPONENT OR SYSTEM MANUFACTURED OR SOLD BY GARMIN (“THE GARMIN PRODUCT”), YOU AGREE TO BE BOUND BY THE TERMS AND CONDITIONS OF THE FOLLOWING SOFTWARE LICENSE AGREEMENT. PLEASE READ THIS AGREEMENT CAREFULLY. Garmin Ltd. and its subsidiaries (“Garmin”) grants you a limited license to use the software embedded in the Garmin Product (the “Software”) in binary executable form in the normal operation of the Garmin Product. Title, ownership rights, and intellectual property rights in and to the Software remain with Garmin and/or its third-party providers. You acknowledge that the Software is the property of Garmin and/or its third-party providers and is protected under the United States of America copyright laws and international copyright treaties. You further acknowledge that the structure, organization, and code of the Software are valuable trade secrets of Garmin and/or its third-party providers and that the Software in source code form remains a valuable trade secret of Garmin and/or its third-party providers. You agree not to reproduce, decompile, disassemble, modify, reverse assemble, reverse engineer, or reduce to human readable form the Software or any part thereof or create any derivative works based on the Software. You agree not to export or re-export the Software to any country in violation of the export control laws of the United States of America.

## **Transmitter Grant of Equipment Authorization**

### **1. FCC**

011-03519-00, 011-03784-00, and 011-03784-10 contain FCC ID: QOQWT32I

011-03519-01, 011-03784-01, and 011-03784-11 contain FCC ID: 2ADHKBM83SM1

#### **NOTE**

This device complies with part 15 of the FCC Rules. Operation is subject to the following two conditions:

(1) This device may not cause harmful interference, and (2) this device must accept any interference received, including interference that may cause undesired operation.

This equipment has been tested and found to comply with the limits for a Class B digital device, pursuant to part 15 of the FCC Rules. These limits are designed to provide reasonable protection against harmful interference in a residential installation. This equipment generates, uses and can radiate radio frequency energy, and if not installed and used in accordance with the instructions, may cause harmful interference to radio communications. However, there is no guarantee that interference will not occur in a particular installation. If this equipment does cause harmful interference to radio or television reception, which can be determined by turning the equipment off and on, the user is encouraged to try to correct the interference by one or more of the following measures:

- Reorient or relocate the receiving antenna
- Increase the separation between the equipment and receiver
- Connect the equipment into an outlet on a circuit different from that to which the receiver is connected
- Consult the dealer or an experienced radio/TV technician for help

#### **FCC RF Radiation Exposure Statement:**

This equipment complies with FCC radiation exposure limits set forth for an uncontrolled environment. This equipment should be installed and operated with minimum distance 20mm between the radiator and your body. This transmitter must not be co-located or operating in conjunction with any other antenna or transmitter.

### **2. IC**

011-03519-00, 011-03784-00, and 011-03784-10 contain IC: 5123A-BGTWT32I

011-03519-01, 011-03784-01, and 011-03784-11 contain IC: 20266-BM83SM1

#### **NOTE**

This device complies with Innovation, Science and Economic Development Canada license-exempt RSS standard(s). Operation is subject to the following two conditions: (1) this device may not cause interference, and (2) this device must accept any interference, including interference that may cause undesired operation of the device.

Cet appareil est conforme aux normes RSS sans licence du ministère Innovation, Sciences et Développement économique Canada. Son fonctionnement est soumis aux deux conditions suivantes :

(1) ce périphérique ne doit pas causer d'interférences et (2) doit accepter toute interférence, y compris les interférences pouvant entraîner un fonctionnement indésirable de l'appareil.

### **3. Declaration of Conformity**

Hereby, Garmin declares that this product is in compliance with the Directive 2014/53/EU. The full text of the EU declaration of conformity is available at the following internet address:

[www.garmin.com/compliance](http://www.garmin.com/compliance).

### **UK Declaration of Conformity**

Hereby, Garmin declares that this product is in compliance with the relevant statutory requirements. The full text of the declaration of conformity is available at the following internet address:

[www.garmin.com/compliance](http://www.garmin.com/compliance).

**Radio frequency/protocol:** 2.4 GHz @ 2.42 dBm nominal

|

**TABLE OF CONTENTS**

PARAGRAPH	PAGE
<b>Section 1 General Description .....</b>	<b>1-1</b>
1.1 Introduction.....	1-1
1.2 Equipment Description .....	1-1
1.3 Technical Specifications .....	1-2
1.4 Reference Documents .....	1-6
 <b>Section 2 Installation Overview .....</b>	 <b>2-1</b>
2.1 Introduction.....	2-1
2.2 Installation Materials .....	2-1
2.3 Available Accessories.....	2-2
2.4 Installation Considerations .....	2-5
2.5 GMA 245R Status LED .....	2-7
2.6 GMA 245R Installation Guidance for Best Bluetooth Performance .....	2-8
2.7 Cabling and Wiring.....	2-9
2.8 Cooling Air .....	2-9
2.9 Configuration, and Adjustment Options .....	2-10
2.10 Updating Software .....	2-15
2.11 Noise .....	2-16
2.12 Mounting Requirements .....	2-17
 <b>Section 3 Installation Procedure.....</b>	 <b>3-1</b>
3.1 Unpacking Unit.....	3-1
3.2 Electrical Connections .....	3-1
3.3 Jackscrew and Shield Block Backshell Installation Instructions.....	3-2
3.4 Backshell Assembly.....	3-17
3.5 Audio Shield Termination .....	3-17
3.6 Unit Installation .....	3-18
3.7 Post Installation Checkout .....	3-19
3.8 Continued Airworthiness .....	3-20
3.9 Diagnostics Information .....	3-21
3.10 Disabling Bluetooth .....	3-21
 <b>Section 4 System Interconnects .....</b>	 <b>4-1</b>
4.1 Connector Description .....	4-1
4.2 Pin List.....	4-1
4.3 Aircraft Power.....	4-4
4.4 CAN Bus.....	4-4
4.5 Lighting Bus .....	4-5
4.6 Audio Inputs/Outputs and Mic Keys .....	4-6
4.7 Discrete Inputs .....	4-10
4.8 Marker Beacon Antenna, GMA 245R MKR Unit Only .....	4-11

PARAGRAPH

PAGE

**Section A Installation Considerations for Upgrading from a Garmin**

<b>GMA 240 .....</b>	<b>A-1</b>
A.1 Mechanical Considerations .....	A-1
A.2 Electrical Considerations .....	A-1
A.3 GMA 240 to GMA 245 Retrofit Connections .....	A-2
 <b>Appendix B Outline and Installation Drawings .....</b>	<b>B-1</b>
 <b>Appendix C Interconnect Drawings.....</b>	<b>C-1</b>



**LIST OF FIGURES**

<b>FIGURE</b>	<b>PAGE</b>
<b>Section 1 General Description .....</b>	<b>1-1</b>
<b>Section 2 Installation Overview .....</b>	<b>2-1</b>
Figure 2-1 GMA 245R MKR Marker Beacon Coaxial Cable D-Sub Termination .....	2-6
Figure 2-2 GMA 245R Bluetooth Transceiver Location .....	2-8
Figure 2-3 SD Card Slot and DIP Switch Locations .....	2-11
Figure 2-4 Front Panel Configuration .....	2-13
Figure 2-5 GMA 245 Unit Rack (115-00262-00) .....	2-17
Figure 2-6 GMA 245R w/Mounting Brackets on Front and Back .....	2-18
Figure 2-7 GMA 245R w/Mounting Brackets on Sides .....	2-18
<b>Section 3 Installation Procedure .....</b>	<b>3-1</b>
Figure 3-1 GMA 245R Jackscrew Backshell Assembly .....	3-4
Figure 3-2 GMA 245 Shield Block Backshell Assembly .....	3-5
Figure 3-3 Method A.1 for Shield Termination .....	3-6
Figure 3-4 Insulation/Contact Clearance .....	3-8
Figure 3-5 Method A.2 (Daisy Chain) for Shield Termination .....	3-10
Figure 3-6 Method B.1 (Quick Term) for Shield Termination .....	3-12
Figure 3-7 Method B.2 (Daisy Chain-Quick Term) for Shield Termination .....	3-13
Figure 3-8 Daisy Chain between Methods A and B .....	3-14
Figure 3-9 Jackscrew D-Sub Spliced Signal Wire illustration .....	3-15
Figure 3-10 Shield Block D-Sub Spliced Signal Wire illustration .....	3-16
Figure 3-11 Rear View of Rack and Connectors .....	3-17
Figure 3-12 GMA 245 Audio Shield Termination (top and bottom) .....	3-17
Figure 3-13 GMA 245R Audio Shield Termination (top and bottom) .....	3-18
Figure 3-14 Diagnostics Mode .....	3-21
<b>Section 4 System Interconnects .....</b>	<b>4-1</b>
Figure 4-1 Rear View of Backplate and Connectors .....	4-1
Figure 4-2 Rear Connectors J2401 & J2402, Viewed from Back of Unit .....	4-1
<b>Section A Installation Considerations for Upgrading from a Garmin GMA 240 .....</b>	<b>A-1</b>
Figure A-1 GMA 240 to GMA 245 Retrofit Connections .....	A-2
<b>Appendix B Outline and Installation Drawings .....</b>	<b>B-1</b>
Figure B-1 GMA 245 Outline Drawing .....	B-1
Figure B-2 GMA 245 Installation Drawing .....	B-2
Figure B-3 GMA 245R Outline Drawing, End Mount Bracket Installation .....	B-3
Figure B-4 GMA 245R Outline Drawing, Side Mount Bracket Installation .....	B-4
Figure B-5 GMA 245R Installation Drawing, End and Side Bracket Mounting .....	B-5

<b>FIGURE</b>	<b>PAGE</b>
Figure B-6 GMA 245 Panel Cutout Drawing.....	B-6
<b>Appendix C Interconnect Drawings .....</b>	<b>C-1</b>
Figure C-1 Notes for Example Interconnect Drawings .....	C-1
Figure C-2 J2401 Connector Example Interconnect Drawing.....	C-2
Figure C-3 J2402 Connector Example Interconnect Drawing.....	C-3
Figure C-4 Lighting Bus Example Interconnect Drawing .....	C-4
Figure C-5 Mono Audio Example Interconnect Drawing .....	C-5
Figure C-6 Four Passenger Headset Wiring Example Interconnect Drawing .....	C-6
Figure C-7 LEMO Jack Wiring Example Interconnect Drawing .....	C-7
Figure C-8 J2401 & J2402 Connector Layout Drawing.....	C-8

**LIST OF TABLES**

TABLE	PAGE
<b>Section 1 General Description .....</b>	<b>1-1</b>
Table 1-1 Physical Characteristics GMA 245 .....	1-2
Table 1-3 Electrical Characteristics .....	1-3
Table 1-2 Physical Characteristics GMA 245R.....	1-3
Table 1-5 GMA 245/245R Power Requirements .....	1-5
Table 1-6 GMA 245 Power Requirements .....	1-5
Table 1-4 Speaker Output .....	1-5
Table 1-8 Reference Documents.....	1-6
Table 1-7 GMA 245R Power Requirements.....	1-6
 <b>Section 2 Installation Overview .....</b>	 <b>2-1</b>
Table 2-1 Catalog Part Numbers .....	2-1
Table 2-2 Contents of GMA 245 Standard Installation Kit.....	2-2
Table 2-3 Contents of GMA 245R Standard Kit .....	2-2
Table 2-4 Contents of GMA 245R MKR Standard Kit .....	2-2
Table 2-5 Contents of GMA 245 Back Plate Kit (011-00678-00, also used for GMA 240/340).....	2-2
Table 2-6 Contents of GMA 245 Conn Kit (011-02302-00, also used for GMA 35/350) ...	2-3
Table 2-7 Contents of GMA 245 Ring Terminal Kit (011-04151-00) .....	2-3
Table 2-8 Contents of GMA 245 Pre-bagged Screws “D” (011-02650-03).....	2-3
Table 2-9 Contents of GMA 245R Conn Kit (011-03828-00/-10) .....	2-3
Table 2-10 Pin and Crimp Tool Part Numbers .....	2-6
Table 2-11 Status LED Indications.....	2-7
Table 2-12 GMA 245 DIP Switch Configuration Settings.....	2-11
Table 2-13 GMA 245R DIP Switch Configuration Settings .....	2-12
Table 2-14 Hardwire Configuration Options.....	2-14
 <b>Section 3 Installation Procedure.....</b>	 <b>3-1</b>
Table 3-1 Pin Contact Part Numbers .....	3-1
Table 3-3 Parts supplied for a GMA 245R Jackscrew Backshell Installation (Figure 3-1) .	3-2
Table 3-2 Recommended Crimp Tools.....	3-2
Table 3-4 Parts supplied for a GMA 245 Backshell Installation (Figure 3-2) .....	3-3
Table 3-5 Parts not supplied for a Backshell Installation (Figure 3-1).....	3-3
Table 3-6 Shielded Cable Preparations for Garmin Connectors.....	3-6
Table 3-7 Shielded Cable Preparations – (Quick Term).....	3-12
 <b>Section 4 System Interconnects .....</b>	 <b>4-1</b>
Table 4-1 J2401 Pin Assignments .....	4-1
Table 4-2 J2402 Pin Assignments .....	4-3
Table 4-3 Aircraft Power .....	4-4

<b>TABLE</b>	<b>PAGE</b>
Table 4-4 CAN Bus .....	4-4
Table 4-5 Lighting Bus .....	4-5
Table 4-6 Mic Audio Inputs and Mic Keys .....	4-6
Table 4-7 COM Audio and Mic Keys .....	4-6
Table 4-8 Alert Audio I/O .....	4-7
Table 4-9 AUX and NAV Audio Inputs .....	4-7
Table 4-10 Failsafe Warning Audio .....	4-8
Table 4-11 Music Inputs .....	4-8
Table 4-12 TEL Audio/XCVR 3 I/O .....	4-9
Table 4-13 Headset Outputs .....	4-9
Table 4-14 Speaker Audio Output .....	4-10
Table 4-15 Discrete Inputs .....	4-10
Table 4-16 Discrete Outputs .....	4-10
Table 4-17 Marker Beacon Antenna Pins .....	4-11

<b>Section A Installation Considerations for Upgrading from a Garmin GMA 240 .....</b>	<b>A-1</b>
--	------------

# 1 GENERAL DESCRIPTION

## 1.1 Introduction

This manual is intended to provide mechanical and electrical information for use in the planning and design of an installation of the GMA 245 into an aircraft. This manual is not a substitute for an approved airframe-specific maintenance manual, installation design drawing, or complete installation data package. Attempting to install equipment by reference to this manual alone and without first planning or designing an installation specific to your aircraft may compromise your safety and is not recommended.

## 1.2 Equipment Description

The Garmin GMA 245 Audio Panel is not a TSO-certified product and has received no FAA approval or endorsement.

The GMA 245 is a high-fidelity digital audio panel that collects, processes, and distributes audio signals to crew and passengers. The GMA 245 digital signal processing (DSP) core filters the audio signals and provides digital audio routing to minimize noise.

The GMA 245 provides a speaker output for use as a cockpit speaker. The GMA 245 also includes a cockpit voice recorder and playback feature to help in situations where a COM transmission may need to be heard again. In addition, the GMA 245 uses Bluetooth for listening to music and making phone calls, or sending headset audio to a VIRB XE, and a 10 Watt USB charge port for phones and tablets.

Other features include intuitive configuration, a lighting bus input, SD Card socket for code loads and Bluetooth firmware updates, an 8 position DIP switch for installation settings, and multiple audio switching functions. LED-illuminated push-buttons (keys) allow audio selection and annunciation for selection of NAV, COM, and other audio. Photocell dimming circuitry automatically adjusts the brightness of the annunciators. Backlighting is controlled by the aircraft lighting bus inputs if the lighting bus is connected. If the lighting bus is not connected, backlighting is controlled by the photocell. A fail-safe circuit connects the pilot's headset and microphone directly to COM 1 and a fail-safe warning audio input in the event that power is interrupted or the unit is turned off.

The GMA 245 has 2 music inputs in addition to the Bluetooth, NAV, COM, and ICS selections. The GMA 245 is easily configurable without an external PC connection. The GMA 245 has automatic intercom squelch and optional keyed intercom squelch. The GMA 245 also contains a CAN Bus that will interface to the G3X Touch system.

The GMA 245R is a remote mount version of the GMA 245. The GMA 245R provides audio system capabilities to a Garmin avionics system such as the G3X Touch (which provides control integration for the GMA 245R). Garmin provides two versions of the GMA 245R which are identifiable by the Garmin Part Number (GPN) marked on the side of the unit. The GMA 245R marked with the GPN 011-03784-10/011-03784-11 adds Marker Beacon Receiver capability to the unit. For referencing purposes only, this document identifies this version of the GMA 245R as GMA 245R MKR when applicable.

### 1.2.1 Features Summary

- 6 Microphone Inputs - Pilot, Copilot, 4 Passenger
- 2 Microphone Keys - Pilot, Copilot
- 3 Transceiver Channels - COM 1, COM 2, TEL
- 5 Receiver Inputs - NAV 1, NAV 2, AUX 1, AUX 2, AUX 3
- 2 Music Inputs
- 4 Alert Inputs (unswitched)
- 1 Speaker Output
- 3 Headset Outputs - Pilot, Copilot, Passenger (passenger output can drive 4 headsets)
- 5 Discrete Inputs
- 1 Discrete Outputs
- 1 Failsafe Channel - (only heard during failed mode or power off)
- 1 CAN Bus Interface
- Lighting Bus
- Bluetooth (not shared with Music 1 or Music 2)
- SD Card Socket
- 8 Position DIP Switch
- USB Charge Port
- Marker Beacon Receiver (GMA 245R MKR version only)

## 1.3 Technical Specifications

### 1.3.1 Physical Characteristics

**Table 1-1 Physical Characteristics GMA 245**

Characteristic	Specification
Bezel Height	1.30 inches (33.0 mm)
Bezel Width	6.30 inches (160.0 mm)
Rack Height (Dimple to Dimple)	1.33 inches (34.0 mm)
Rack Width	6.30 inches (160.0 mm)
Depth Behind Panel with Connectors (measured from face of aircraft panel to rear of connector backshells)	8.09 inches (205.0 mm)
GMA 245 Weight (Unit Only)	1.10 lbs (0.49 kg)
GMA 245 Weight (Installed with rack, backplate, and connectors)	1.78 lbs (0.81 kg)

**Table 1-2 Physical Characteristics GMA 245R**

Characteristic	Specification
Unit Height	1.36 inches (34.5 mm)
Unit Width	6.29 inches (159.8 mm)
Unit Depth	6.59 inches (167.3 mm)
Unit Depth w/End Mount Bracket Installation	7.71 inches (195.7 mm)
Unit Depth w/End Mount Installation and Connectors	9.06 inches (230.1 mm)
Unit Width w/Side Mount Bracket Installation	7.21 inches (183.1 mm)
Unit Depth w/Side Mount Bracket Installation and Connectors	8.50 inches (215.8 mm)
GMA 245R (011-03784-00/011-03784-01) Weight (includes Unit, Mounting Bracket, and Connectors)	1.39 lbs (0.63 kg)
GMA 245R MKR (011-03784-10/011-03784-11) Weight (includes Unit, Mounting Bracket, and Connectors)	1.42 lbs (0.64 kg)

### 1.3.2 Electrical Specifications

**Table 1-3 Electrical Characteristics**

Characteristic	Specification
Temperature Range	-20° C to +55° C (Operation) -55° C to +85° C (Storage) -40° C to +70° C (Short term)
Altitude	55,000 Feet Overpressure -15,000 Feet
Audio Panel Functions	Dedicated Transceiver inputs: 3 (including TEL) Dedicated Receiver inputs: 5 (AUX 1, 2, and 3, selected with a single key; NAV 1 and 2 independently selectable) Alert (unswitched) inputs: 4 (each with configurable volume) Input impedance: 600 Ω Input isolation: 60 dB minimum Alert/Receiver/Transceiver bandwidth: 100 Hz to 6.5 kHz Special functions: Fail-safe operation All inputs use MASQ™ processing (Master Avionics Squelch) Max input 5 Vrms

**Table 1-3 Electrical Characteristics**

Characteristic	Specification
Intercom Functions	<p>Positions: 6 - Pilot, Copilot, 4 Passengers</p> <p>Volume controls: 4 (Pilot ICS, Pilot Music, Copilot/Passenger ICS, Copilot/Passenger Music)</p> <p>Microphone input impedance: 150 <math>\Omega</math> (compatible with 150 to 600 <math>\Omega</math> mics)</p> <p>Microphone bias voltage: 11 Vdc delivered through 470 <math>\Omega</math></p> <p>Intercom isolation modes: 3 - Pilot, Crew, and All</p> <p>Telephone interfaces: 1 full-duplex (use rear LRU pins or Bluetooth)</p> <p>ICS Auto-Squelch/VOX: Independent DSP (digital signal processing) determined thresholds for each mic</p> <p>Note that keyed intercom is optional. Auto-squelch not available when using keyed ICS.</p>
Headphone Outputs	<p>Output amplifiers: 3 Stereo - Pilot, Copilot, Passengers</p> <p>Power, Load, and Distortion: 65 mW into 150 Ohms with &lt;10%</p> <p>THD+N @ 10% output &lt;3% THD+N</p> <p>Typical Operating Distortion: &lt;1% THD+N</p> <p>3dB Frequency Response Bandwidth: 20 Hz to 20 kHz for Music</p> <p>350 Hz to 6.5 kHz for Other Audio (MICs, Radios, Alerts)</p>
Music Functions	<p>Music inputs (stereo): 2</p> <p>Music input impedance: 600 <math>\Omega</math> (differential)</p> <p>Music gain: +24dB @ max. volume</p> <p>Music input level:&lt;200 mVrms for full power* output @ max music volume knob position (typ.)</p> <p>3.0 Vrms max music input level</p> <p>Music bandwidth: 20 Hz to 20 kHz @ full power output</p> <p>Music distortion: &lt;0.1% THD+N (typ.) @ full power, full bandwidth</p> <p>*Full power output refers to 65 mW into 150 <math>\Omega</math> at the headset</p>
Bluetooth Connectivity	<p>Bluetooth 3.00 Compliant (011-03519-00, 011-03784-00, and 011-03784-10). Bluetooth 5.0 Compliant (011-03519-01, 011-03784-01, and 011-03784-11). Allows music, cell phone calls, and interface with the VIRB XE action camera. Bluetooth supports HFP (including HFP v1.6 Wide Band Speech mode), A2DP, and AVRCP.</p> <p>The GMA stores 10 paired devices and overwrites the least recently connected device when a new device is paired. Only 1 Bluetooth connection allowed at one time. The VIRB XE cannot be connected when using a phone (and vice versa).</p>
USB Charge Port	<p>USB charge port - Rated for 10 W. The GMA 245 charge port features USB port detection that will connect the optimum charge rate for the device connected. The charge port supports a maximum of 2.1 Amp charge current for devices. The USB charge port will shutdown and protect the GMA for current draw above 2.3 Amps.</p>



**Table 1-4 Speaker Output**

Aircraft Voltage	Speaker Impedance	Output Power
14V	4 Ω	3 Watts
	8 Ω	Not Recommended
28V	4 Ω	10 Watts
	8 Ω	7 Watts

### 1.3.3 Power Requirements

The GMA 245/245R will operate down to emergency voltage (9 Volts). Below 11 Volts, the USB charge port and the speaker are disabled.

**Table 1-5 GMA 245/245R Power Requirements**

Characteristic	Specification
Input Voltage Range	11 to 33 Vdc
Leakage Current*	< 1 mA

\*Current the unit draws if turned off (GMA 245 is turned off by the knob, GMA 245R can only be turned off by breaker).

**Table 1-6 GMA 245 Power Requirements**

Characteristic	Current Draw	Power Consumption
Idle Current*	0.32 A @ 14 VDC	4.48 W @ 14 VDC
	0.18 A @ 28 VDC	5.04 W @ 28 VDC
Typical Operating Current without USB charge port being used.	0.77 A @ 14 VDC	10.78 W @ 14 VDC
	0.40 A @ 28 VDC	11.20 W @ 28 VDC
Maximum Current with no USB charge port connection	1.11 A @ 14 VDC	15.54 W @ 14 VDC
	0.87 A @ 28 VDC	24.36 W @ 28 VDC
Maximum Current with USB charge port connection	2.31 A @ 14 VDC	32.34 W @ 14 VDC
	1.45 A @ 28 VDC	40.60 W @ 28 VDC

\*Unit current drawn with power applied, no audio, and minimum lighting.

**Table 1-7 GMA 245R Power Requirements**

Characteristic	Current Draw	Power Consumption
Idle Current*	0.32 A @ 14 VDC	4.48 W @ 14 VDC
	0.18 A @ 28 VDC	5.04 W @ 28 VDC
Typical Operating Current without USB charge port being used.	0.60 A @ 14 VDC	8.40 W @ 14 VDC
	0.32 A @ 28 VDC	8.96 W @ 28 VDC
Maximum Current with no USB charge port connection	0.92 A @ 14 VDC	12.88 W @ 14 VDC
	0.77 A @ 28 VDC	21.56 W @ 28 VDC
Maximum Current with USB charge port connection	2.1 A @ 14 VDC	29.40 W @ 14 VDC
	1.35 A @ 28 VDC	37.80 W @ 28 VDC

\*Unit current drawn with power applied, no audio.

## 1.4 Reference Documents

The following publications are sources of additional information for installing the GMA 245. The installer should read all referenced materials along with this manual before attempting installation.

**Table 1-8 Reference Documents**

Part Number	Document
190-01115-01	G3X Installation Manual
190-01754-00	G3X Touch Pilot's Guide
190-01879-10	GMA 245 Pilot's Guide

## 2 INSTALLATION OVERVIEW

### 2.1 Introduction

This section provides the necessary information for the installation and checkout of the GMA 245 Audio Panel. Installation of the GMA 245 will differ according to equipment location and other factors. The appendices contain interconnect wiring diagrams, mounting dimensions, and information pertaining to installation.

Careful planning and consideration of the suggestions in this section are required to achieve the desired performance and reliability from the GMA 245. The guidance of FAA advisory circulars AC 43.13-1B and AC 43.13-2B, where applicable, may be found useful for making retro-fit installations that comply with FAA regulations.

### 2.2 Installation Materials

#### 2.2.1 Unit Configurations

**Table 2-1 Catalog Part Numbers**

Model	Catalog Part Number	Unit Only Part Number
GMA 245 Unit Only, SN Prefix 3YL0	010-01318-00	011-03519-00
GMA 245 Standard (includes items in <a href="#">Table 2-2</a> ), SN Prefix 3YL0	010-01318-01	011-03519-00
GMA 245 Unit Only, SN Prefix 3YL1	010-01318-02	011-03519-01
GMA 245 Standard (includes items in <a href="#">Table 2-2</a> ), SN Prefix 3YL1	010-01318-03	011-03519-01
GMA 245R Unit Only, SN Prefix 44V0	010-01471-00	011-03784-00
GMA 245R Standard Kit (includes items in <a href="#">Table 2-3</a> ), SN Prefix 44V0	010-01471-01	011-03784-00
GMA 245R Unit Only, SN Prefix 44V2	010-01471-02	011-03784-01
GMA 245R Standard Kit (includes items in <a href="#">Table 2-3</a> ), SN Prefix 44V2	010-01471-03	011-03784-01
GMA 245R MKR Unit Only, SN Prefix 44V1	010-01471-10	011-03784-10
GMA 245R MKR Standard Kit (includes items in <a href="#">Table 2-4</a> ), SN Prefix 44V1	010-01471-11	011-03784-10
GMA 245R MKR Unit Only, SN Prefix 44V3	010-01471-12	011-03784-11
GMA 245R MKR Standard Kit (includes items in <a href="#">Table 2-4</a> ), SN Prefix 44V3	010-01471-13	011-03784-11

## 2.3 Available Accessories

### 2.3.1 Standard Accessories

**Table 2-2 Contents of GMA 245 Standard Installation Kit**

Item	Part Number
Sub-Assy, Back Plate, GMA 245/245R (also used for GMA 240/340) ( <a href="#">Table 2-5</a> )	011-00678-00
Conn Kit, GMA 245/245R (also used for GMA 35/350) ( <a href="#">Table 2-6</a> )	011-02302-00
Sub-Assy, GMA 245, Ring Terminal screw/washer access kit ( <a href="#">Table 2-7</a> )	011-04151-00
SMP, Install Rack, GMA 245 (also used for GMA 240/340)	115-00262-00

**Table 2-3 Contents of GMA 245R Standard Kit**

Item	Part Number
Side Mount Bracket, GMA 245R	115-02282-00 (ordered as 011-04150-00)
Connector Kit, GMA 245R (see <a href="#">Table 2-9</a> )	011-03828-00

**Table 2-4 Contents of GMA 245R MKR Standard Kit**

Item	Part Number
Side Mount Bracket, GMA 245R, PMA	115-02282-10 (ordered as 011-04150-10)
End Mount Bracket, GMA 245R, PMA	115-02283-10 (ordered as 011-04150-11)
Connector Kit, GMA 245R, PMA (see <a href="#">Table 2-9</a> )	011-03828-10

**Table 2-5 Contents of GMA 245 Back Plate Kit (011-00678-00, also used for GMA 240/340)**

Item	Part Number	Quantity
Pre-bagged screws "D" ( <a href="#">Table 2-8</a> )	011-02650-03	1
Nut Cover, SMP	115-00261-00	1
Connector Plate Assembly, DCP	125-00040-00	1
Nut, Std, English, SS, #6-32	210-00036-07	1
Screw, 4-40 x 0.250, PHP, SS/P, w/NYL	211-60234-08	2

**Table 2-6 Contents of GMA 245 Conn Kit (011-02302-00, also used for GMA 35/350)**

Item	Part Number	Quantity
Backshell w/Hardware 25 and 44 pin	011-00950-02	2
Ground Adapter, Shell 1-3	011-01169-00	4
Screw 4-40 x 0.437, FLHP100, SS/P, Nylon	211-63234-11	4
Hi Density D-Sub Connector, Mil Crimp, 44 ckt	330-00185-44	2
Contact Pin, Mil Crimp, Size 22D	336-00021-00	94

**Table 2-7 Contents of GMA 245 Ring Terminal Kit (011-04151-00)**

Item	Part Number	Quantity
Screw, 8-32 x 0.312, PHP, SS/P	211-60209-09	8
Washer, Split Lock, Size 8	212-00018-04	8
Washer, Flat, Non-Std, SS, ID 0.195, OD 0.354	212-20065-00	8

**Table 2-8 Contents of GMA 245 Pre-bagged Screws "D" (011-02650-03)**

Item	Part Number	Quantity
Screw, 4-40 x 0.250, PHP, SS/P, w/NYL	211-60234-08	4
Cable Tie, 4.0"	231-10001-00	1

**Table 2-9 Contents of GMA 245R Conn Kit (011-03828-00/-10)**

Item	Part Number	Quantity
Jackscrew Backshell	011-01855-02	2
Screw, 8-32 x 0.312, PHP, SS/P	211-60209-09	8
Washer, Split Lock, Size 8	212-00018-04	8
Washer, Flat, Non-Std, SS, ID 0.195, OD 0.354	212-20065-00	8
Hi Density D-Sub Connector, Mil Crimp, 44 ckt	330-00185-44	2
Contact Pin, Mil Crimp, Size 22D	336-00021-00	88

### 2.3.2 Additional Equipment Required

- Cables: The installer will fabricate and supply all system cables. Interconnect wiring diagrams are detailed in [Appendix C](#).
- Hardware: #6-32 100° flat head screw (6 ea.) and #6-32 self-locking nut (6 ea.). Hardware required to mount the GMA 245 installation rack is not provided.
- Stereo headphone jacks (up to 6), microphone jacks (up to 6), 3.5mm stereo jacks (up to 2). Insulating type jacks or insulating washers should be used for all jacks to isolate them from aircraft chassis.
- For GMA 245R, Hardware: (4-6 ea) #10-32 bolts and (4-6 ea) #10-32 self-locking nut for installing the mounting bracket to the aircraft frame.
- For GMA 245, Tool: 3/32" Allen for tightening the unit into the rack and backplate.
- Push/Pull (that can be manually reset) circuit breaker (5 Amp recommended).
- Tie Wraps or Lacing Cord
- Ring Terminals (for grounding) #8 size, Yellow, Blue, and Pink.
- Silicone Fusion Tape (GPN 249-00114-00) to wrap the cable bundle. Silicone fusion tape is available at most major suppliers like Mouser, Digi-key, and Home Depot.
- Solder Sleeves for terminating the shields of the cable to the GMA backshell. See [Section 3.3](#) for part numbers.
- Optional USB Type A Panel Mount/Bulkhead Jack to Type A USB male cable to use with GMA 245R for connecting to a panel mounted USB jack. Example L-COM parts for reference-UPMAA-1M (3.3 feet), UPMAA-075M (2.46 feet), UPMAA-05M (1.64 feet).
- Heat shrink tubing
- SD card needed for updating software in the GMA 245 when not integrated in a G3X Touch system. Garmin recommends using a 4 GB Sandisk® SD card.

Insulating Washers for Headset and Microphone Jacks can be found at the following suppliers:

#### Dallas Avionics

100053 - Shoulder Washer

100054 - Flat Washer

#### Digi-key

SC1147-ND - Shoulder Washer

SC1146-ND - Flat Washer

#### Mouser

502-S-1029 – Shoulder Washer

502-S-1028 – Flat Washer

#### Newark

S1029 - Shoulder Washer

S1028 - Flat Washer

#### Switchcraft

S1029 – Shoulder Washer

S1028 – Flat Washer

## 2.4 Installation Considerations

The GMA 245 interfaces with various avionics equipment. Fabrication of a wiring harness is required. Sound mechanical and electrical methods and practices are required for installation of the GMA 245.



### NOTE

*3D audio is not available when using a mono headset or in aircraft wired with mono headset jacks. 3D audio (even if enabled), will not be available with mono audio headset jacks or mono headsets. It is recommended that stereo jacks and stereo headsets be used.*

### 2.4.1 Marker Beacon Antenna Installation

#### 2.4.1.1 Location Considerations

The marker beacon antenna should be mounted on a flat surface on the underside of the aircraft body.



### NOTE

*Do not install the antenna inside the aircraft. Installing the antenna inside the aircraft limits the antenna reception and increases the antennas susceptibility to radiation from components inside the aircraft.*

Mount the antenna so that there is a minimum of structure between it and the ground radio stations. Locate it as far away as possible from transmitter antennas.

#### 2.4.1.2 Marker Beacon Antenna Mounting

Install the antenna according to the antenna manufacturer's instructions. If the antenna is being installed on a composite aircraft, ground planes must sometimes be added. Conductive wire mesh, radials or thin aluminum sheets embedded in the composite material provide the proper ground plane allowing the antenna pattern (gain) to be maximized for optimum performance.

#### 2.4.1.3 Marker Beacon Antenna Cable

Use coaxial cable meeting the applicable aviation regulation for the marker beacon antenna. Any cable meeting specifications is acceptable for the installation. When routing antenna cables, observe the following precautions:

- All cable routing should be kept as short and as direct as possible
- Avoid sharp bends
- Avoid routing cables near power sources (e.g., 400 Hz generators, trim motors, etc.) or near power for fluorescent lighting
- Allow a 12 inch minimum separation between any other cables, including antenna cables (e.g ADF, COM, NAV, GS, MARKER)

### 2.4.1.4 Marker Beacon Antenna Cable Installation

This section provides guidance for terminating the coaxial cable into the D-Sub connector. See the system interconnect section for pin assignments.



**NOTE**

Use coaxial cable meeting the applicable aviation regulation for the marker beacon antenna. Route the cable to the D-Sub as described in [Section 2.4.1.3](#).

When terminating the coaxial cable into the D-Sub observe the following guidance (refer to Figure 2-1):

- Keep the distance from the end of the exposed shield to D-Sub as short as possible.
- Ensure the distance from the beginning of the exposed shield to D-Sub is no more than 1.5 inches long.
- Terminate the center conductor by directly connecting it to the D-sub through a crimp pin without a pigtail.

Figure 2-1 below represents a suggested method for terminating the marker beacon coaxial cable using M17/128-RG400 terminated into a high density D-Sub connector. Refer to Table 2-10 for Crimp Tool, Pin, and Crimp Tool Insert part numbers.

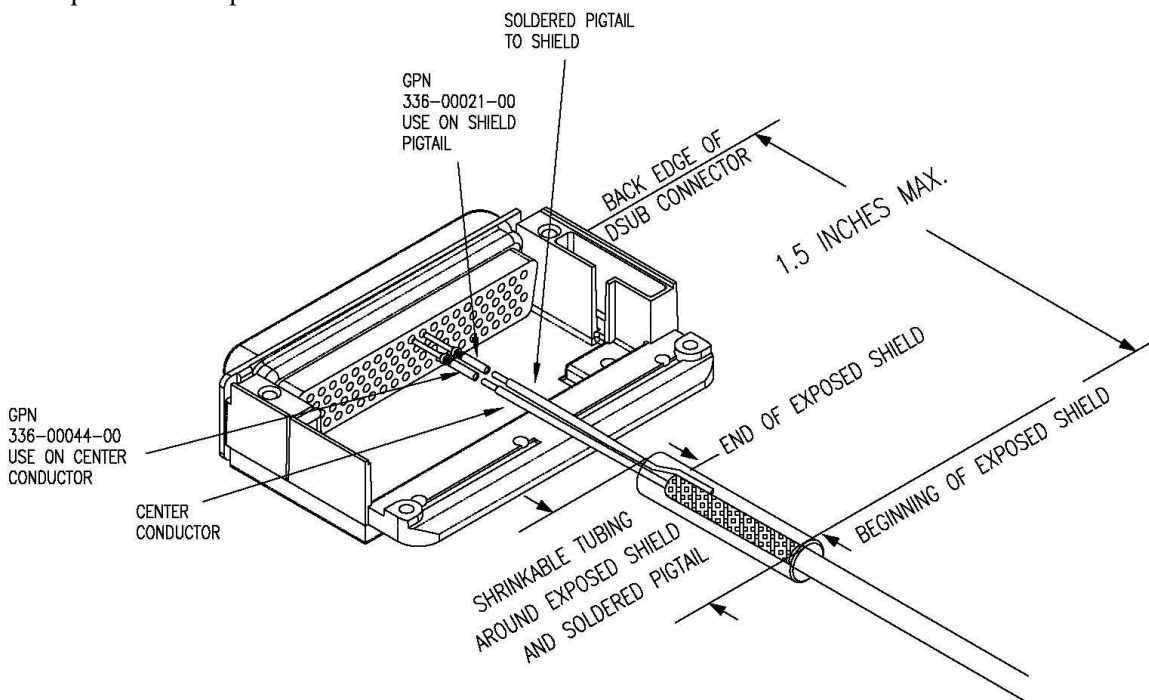

**Figure 2-1 GMA 245R MKR Marker Beacon Coaxial Cable D-Sub Termination**

**Table 2-10 Pin and Crimp Tool Part Numbers**

CRIMP TOOL	PIN	CRIMP TOOL INSERT
DANIELS MANUFACTURING CORP DMC M22520/2-01 GAGE AFM8 CRIMPING TOOL	Garmin Part Number 336-00021-00	K42
	Garmin Part Number 336-00044-00	K774



## 2.5 GMA 245R Status LED

The GMA 245R has red and green status LEDs visible on the front of the unit that indicate the unit's current status. The status indications are:

**Table 2-11 Status LED Indications**

LED Indication	Description
No Light	No Power
Steady Green	On, but not communicating via CAN Bus
Flashing Green	On and communicating via CAN Bus
Red	Hardware Fault
Alternating Red/Green	CAN bus network error two similar devices are configured with the same unit ID

## 2.6 GMA 245R Installation Guidance for Best Bluetooth Performance

The GMA 245 (panel mount) provides optimal Bluetooth performance because the Bluetooth transceiver is mounted inside the cockpit with an unobstructed view of the phone and other devices being used in the cockpit. Good Bluetooth performance can also be obtained with the GMA 245R (remote mount) if mounting location and orientation are selected to keep the instrument panel (and other aircraft metal structures) from blocking the Bluetooth signal.

GMA 245R mounting location/orientation will vary for each installation depending on aircraft body type (metal or fiberglass) and the surrounding structures/equipment. The GMA 245R Bluetooth transceiver is located behind the black plastic front face of the unit as shown in the red rectangle in Figure 2-2.

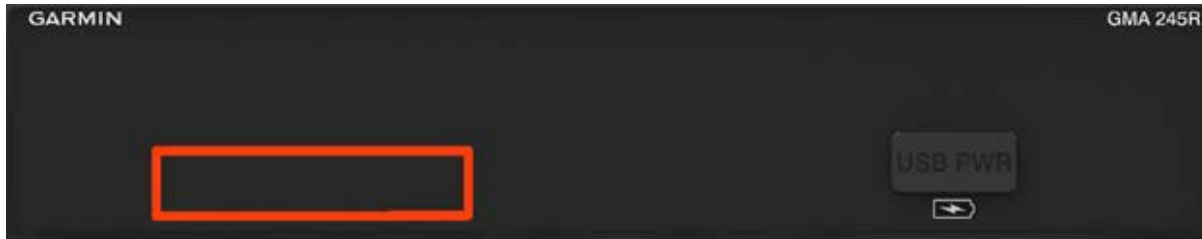

**Figure 2-2 GMA 245R Bluetooth Transceiver Location**

For best performance, mount the GMA 245R with the front of the unit facing the cockpit and centered laterally between the two aircraft sides. For example, mounting the GMA 245R at the bottom of a center radio stack facing into the cockpit (aft) typically works well, although mounting it just below the instrument panel would likely produce better results.

Mounting the GMA 245R with the front of the unit facing perpendicular to the cockpit (facing the left or right side of the aircraft), whether vertically or horizontally mounted, may have reduced connectivity depending on which side of the aircraft surrounding structures/equipment are located.

Mounting the GMA 245R with the face down can function well in locations where the face of the GMA 245R is oriented towards the aircraft cockpit floor, with the area between the floor and the aircraft panel open. Mounting the GMA 245R with the face up can work well depending on what structures/equipment are located between the GMA 245R and the cockpit.

Mounting the GMA 245R with the front face of the unit facing forward may work in some installations, but generally results in reduced Bluetooth performance.

Do not install the GMA 245R in a metal box or beneath a floor panel, as this will attenuate (decrease) the Bluetooth signal. If the installation contains another device that provides a Bluetooth interface, mount the devices apart from each other as much as possible (at minimum, leave a small gap between the devices) to prevent signal interference.

## 2.7 Cabling and Wiring

Refer to the interconnect examples in [Appendix C](#) for wire gauge guidance.

In some cases, a larger gauge wire such as AWG #18 or #20 may be needed for power connections. If using AWG #18 barrel contacts, ensure that no two contacts are mounted directly adjacent to each other. This minimizes the risk of contacts touching and shorting to adjacent pins and to ground.

Use wire and cable meeting the applicable aviation regulation. When routing wire and cable, observe the following precautions:

- Keep wire and cable as short and direct as possible
- Avoid sharp bends
- Avoid routing near power sources (e.g. 400 Hz generators, trim motors, etc) or near power of fluorescent lighting
- For Power and Ground use 2 individual wires for the units to the power source. Do not splice 2 wires to one at the unit for power and ground.



### NOTE

*Avoid installing the unit near heat sources. If this is not possible, ensure that additional cooling is provided. Allow adequate space for installation of cables and connectors. The installer will supply and fabricate all of the cables.*

## 2.8 Cooling Air

The GMA 245 does not have provisions for attaching cooling air, however the thermal characteristics of the installation should always be assessed. An undesirable thermal condition could be created due to the unit's own internal power dissipation combined with restricted ventilation, or due to heat generated by adjacent equipment. Limiting thermal build up, by means of fan or natural convection is always a good practice and recommended to increase the product life.

## 2.9 Configuration, and Adjustment Options

The GMA 245 has several configuration/adjustment options (see [Section 2.9.6](#)). These configuration/adjustments are as follows:

- Wired Telephone Volume
- Auxiliary 1 Volume
- Auxiliary 2 Volume
- Auxiliary 3 Volume
- Alert 1 Volume
- Alert 2 Volume
- Alert 3 Volume
- Alert 4 Volume
- Speaker Volume
- Master Avionics Squelch (Section 2.9.1)
- High Cockpit Noise Option (Section 2.9.2)
- Music In Isolation Option (Section 2.9.3)
- Alerts Mute Music Option (Section 2.9.4)
- Marker Beacon Receiver RF Threshold and Marker Audio Volume (GMA 245R MKR only)

### 2.9.1 Master Avionics Squelch (MASQ) Function

MASQ functions to prevent low level noise from being passed to the headset ear speakers, this is known as “squelching” or muting the audio. To “break” or “open” squelch means that enough audio signal is present that the signal is passed through and can be heard. Increasing this setting increases the signal level required to break/open squelch. If needed, adjust the MASQ SQ level so the audio background noise is muted.

### 2.9.2 High Cockpit Noise Option

Enable to help reduce intercom background noise in very high noise cockpit environments. Disabled by default.

### 2.9.3 Music In Isolation Option

Enable to allow pilot and copilot to hear selected music when PILOT or CREW isolation mode is active. Disabled by default.

### 2.9.4 Alert Mute Music Option

Disable this option to prevent music from being muted when alert audio is heard. Enabled by default.

## 2.9.5 DIP Switch Configuration

The DIP switches are used to select the configuration settings listed in Table 2-12, and are located on the right side of the unit next to the SD card slot as shown in Figure 2-3.

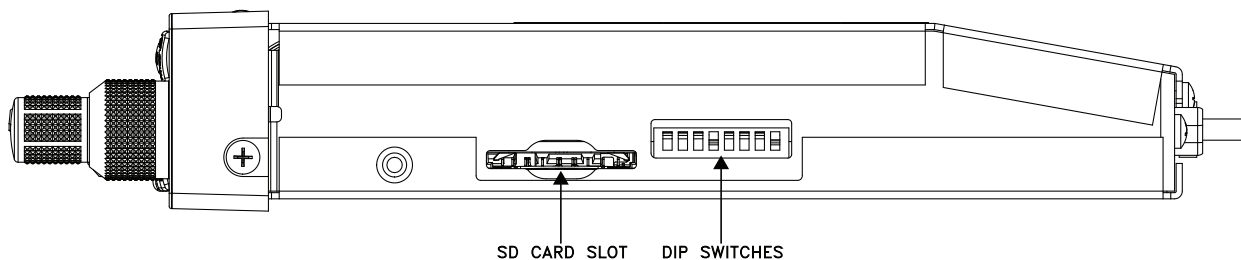

**Figure 2-3 SD Card Slot and DIP Switch Locations**

### 2.9.5.1 GMA 245 DIP Switch Configuration Settings

The GMA 245 DIP switch configuration settings are listed in Table 2-12. Per the label attached to the top cover of the unit, the down switch position is ON, the up switch position is OFF.

**Table 2-12 GMA 245 DIP Switch Configuration Settings**

Switch	Function	Description
1	ENABLED KEYED ICS	When set to ON, the intercom system (ICS) will only allow intercom MIC audio to be heard when the corresponding ICS KEY for the MIC position is pressed. When set to ON, auto squelch will NOT be active.
2	PILOT IN RIGHT SEAT	This setting is for intercom 3D audio. Normally the Pilot will be positioned to the left in the Copilot's headset, and the Copilot will be positioned to the right in the Pilot's headset. When set to ON, this setting reverses that so the Pilot is positioned to the right in the Copilot's headset, and the Copilot is positioned to the left in the Pilot's headset.
3	MUTE ON COM TX	When set to ON, the monitored COM radio is muted during mic-selected COM transmission (mic-selected COM is still heard, but not the monitored COM radio).
4	RESERVED	LEAVE SWITCH IN OFF POSITION
5	RESERVED	LEAVE SWITCH IN OFF POSITION
6	RESERVED	LEAVE SWITCH IN OFF POSITION
7	RESERVED	LEAVE SWITCH IN OFF POSITION
8	CONFIGURATION LOCKOUT	When set to ON, this prevents use of the GMA 245's config mode UI. When installed in a G3X Touch system, this setting prevents the use of the GMA 245's config mode UI, but it does not prevent an integrated G3X Touch system from configuring the unit.

### 2.9.5.2 GMA 245R DIP Switch Configuration Settings

The GMA 245R DIP switch configuration settings are listed in Table 2-13.

**Table 2-13 GMA 245R DIP Switch Configuration Settings**

Switch	Function	Description
1	ENABLED KEYED ICS	When set to ON, the intercom system (ICS) will only allow intercom MIC audio to be heard when the corresponding ICS KEY for the MIC position is pressed. When set to ON, auto squelch will NOT be active.
2	PILOT IN RIGHT SEAT	This setting is for intercom 3D audio. Normally the Pilot will be positioned to the left in the Copilot's headset, and the Copilot will be positioned to the right in the Pilot's headset. When set to ON, this setting reverses that so the Pilot is positioned to the right in the Copilot's headset, and the Copilot is positioned to the left in the Pilot's headset.
3	MUTE ON COM TX	When set to ON, the monitored COM radio is muted during mic-selected COM transmission (mic-selected COM is still heard, but not the monitored COM radio).
4	RESERVED	LEAVE SWITCH IN OFF POSITION
5	RESERVED	LEAVE SWITCH IN OFF POSITION
6	RESERVED	LEAVE SWITCH IN OFF POSITION
7	RESERVED	LEAVE SWITCH IN OFF POSITION
8	CONFIGURATION LOCKOUT	LEAVE SWITCH IN OFF POSITION

## 2.9.6 Front Panel Configuration (GMA 245 only)

Enter configuration mode by holding down the COM1 MIC and SPKR keys while turning the unit on.

When in configuration mode, pressing the PLAY key will announce the current software/database product version, e.g. “system two dot zero zero”.

When in configuration mode, pressing the COM1 MIC key selects volume mode. Press the COM1 MIC key until the desired volume is announced, e.g. “auxiliary one volume”.

When in configuration mode, pressing the COM2 MIC key selects Master Avionics Squelch mode.

When in configuration mode, pressing the SPKR key announces the current option, e.g. “Alerts Mute Music Enabled” or “Cockpit High Noise Disabled”.

When in configuration mode, pressing the PILOT key increases the selected setting as indicated by the LEDs on the Level Bar.

When in configuration mode, pressing the CREW key decreases the selected setting as indicated by the LEDs on the Level Bar.

When adjusting Options in configuration mode, the PILOT and CREW keys are used to indicate the current state and change the state. If the option is enabled, the PILOT key is lit solid and the CREW key flashes (indicating that the CREW key can be pushed to disable the option). Likewise, if the option is disabled, the CREW key is lit solid and the PILOT key flashes (indicating that the PILOT key can be pushed to enable the option). The Level Bar is not used when in the options mode.

When in configuration mode, the LEDs in the Level Bar (Figure 2-4) light to indicate an increase/decrease in the selected setting.

When in configuration mode, pressing COM1 and AUX keys simultaneously resets the configuration and operating state back to factory defaults.



**Figure 2-4 Front Panel Configuration**

## 2.9.7 Hardwired Configuration Options

The configuration options in Table 2-14 are available by wiring the inputs to a pushbutton to ground (see [Figure C-2](#) and [Figure C-3](#)).

**Table 2-14 Hardwire Configuration Options**

Connector	Pin	Description	Type	Function
J2401	16	PILOT ICS KEY*	Input	If DIP switch 1 is on, this active low input, when grounded, will allow microphone audio to the intercom from Pilot MIC.
J2401	24	COM ACTIVE OUT*	Output	This output is active when Receiving selected COM audio or when transmitting on the MIC selected COM. This output can be used to connect to other devices to inhibit other devices from playing audio into the GMA while there is COM activity.
J2402	13	PASSENGER ICS KEY*	Input	If DIP switch 1 is on, this active low input, when grounded, will allow microphone audio to the intercom from Passenger MIC.
J2402	20	COM SWAP*	Input	When grounded the MIC selected COM will swap.
J2402	22	PLAY KEY*	Input	When grounded the last voice recorded message will play. While playing, if grounded again, the previous message will play.
J2402	30	COPILOT ICS KEY*	Input	If DIP switch 1 is on, this active low input, when grounded, will allow microphone audio to the intercom from Copilot MIC.

\*Active Low



## 2.10 Updating Software

The G3X Touch system is used to update the GMA 245R software. The GMA 245 (if connected in a G3X Touch system), will also get software updates from the G3X Touch system. See the G3X Installation Manual for instruction on performing software updates using the G3X Touch system.

When the GMA 245 is not integrated in a G3X Touch system, updating software is performed using an SD card. Garmin recommends using a 4GB Sandisk® SD Card.

### 2.10.1 Checking Software Version

The GMA 245 comes pre-loaded with system software. However, if the software is out of date, it is recommended that current software be loaded from an SD card into the GMA 245.

The current version of software can be retrieved in the configuration operating mode. See [Section 2.9.6](#) for instructions.

### 2.10.2 Creating a Software Loader SD Card

The software update mode allows the installer to load unit software using an SD software loader card.



#### NOTE

*The application to create a loader card requires Windows 2000, XP, Vista, Windows 7, or Windows 10. There is no Mac support at this time.*

1. Go to the GMA 245 web page on Garmin's website.
2. Download the GMA 245 software to your PC.
3. Ensure that an SD card (Garmin recommends a Sandisk® brand 4GB SD card) is connected to the PC in the SD card slot.
4. Run the executable file that was downloaded and follow the prompts on the screen to create the software loader card.
5. After the card has been created, select finish to complete the process.
6. Remove the card from the slot. The loader card is now ready to use.

### 2.10.3 Loading Software to the GMA 245

1. Remove the unit from the rack using a 3/32" Allen tool.
2. The SD card slot is on the right side of the unit next to the dip switches. Insert the SD card with pins facing down (toward the bottom of the unit).
3. Install the unit back into the rack using a 3/32" Allen tool.
4. Press and hold the COM1 MIC and TEL keys while turning the unit on.
5. The GMA 245 will begin checking the SD card for updated software.
  - a) Do not turn the GMA 245 off or remove power during the update process.
  - b) The top row of keys, from left to right, will indicate the progress of the update process.
  - c) If a problem is encountered during the update process, all keys on the top row will flash at a 1 Hz rate.

6. If a problem is encountered during the update process, follow the below steps for possible solutions.
  - a) Use the Pilot Knob to power cycle the GMA 245, then perform the process again.
  - b) Attempt to re-download the GMA 245 software to the PC, recreating the loader SD card, and perform the process again.
  - c) Recreate the loader card using the recommended Sandisk® brand 4GB SD card, and attempt the update process again.
  - d) If still having difficulty performing the update, contact Garmin Aviation Technical support.
7. Once the update process is finished the GMA 245 will automatically reboot back into normal operating mode.
8. The update card does not need to be removed after the update process and can be left in the GMA 245 at the installer's discretion.

Once the unit has been updated, verify the correct software version is installed (see [Section 2.9.6](#) for instructions). If a Bluetooth firmware update is included with the software update, the Bluetooth firmware will be updated automatically after the GMA 245 reboots. While a Bluetooth firmware update is being performed in the GMA 245, the Bluetooth annunciator will blink in an ON - ON - OFF pattern for several minutes. When the Bluetooth update is completed, the Bluetooth functions will return to normal operation.

## 2.11 Noise

Because the audio panel is a point in the aircraft where signals from many pieces of equipment are brought together, care must be taken to minimize effects from coupled interference and ground loops.

Coupled interference can sneak into audio system interconnecting cables when they are routed near large AC electric fields, AC voltage sources, and pulse equipment (strobes, spark plugs, magnetos, EL displays, CRTs, etc). Interference can also couple into audio system interconnecting cables by magnetic induction when they are routed near large AC current-carrying conductors or switched DC equipment (heaters, solenoids, fans, autopilot servos, etc).

Ground loops are created when there is more than one path in which return currents can flow, or when signal returns share the same path as large currents from other equipment. These large currents create differences in ground potential between the various equipment operating in the aircraft. These differences in potential can produce an additive effect at an audio panel signal input.

The audio panel may "see" the desired input signal plus an unwanted component injected by ground differentials, a common cause of alternator-related noise. This is the main reason why all audio jacks should be isolated from ground. Terminating audio shields just at one end eliminates another potential ground loop injection point.

Single-point grounding cannot be overstressed for the various avionics producing and processing audio signals. Single-point, in this context, means that the various pieces of equipment share a single common ground connection back to the airframe. Good aircraft electrical/charging system ground bonding is also important.

The wiring diagrams and accompanying notes in this manual should be followed closely to minimize noise effects.

## 2.12 Mounting Requirements

The GMA 245 mounting surface must be capable of providing structural support and electrical bond to the aircraft to minimize radiated EMI and provide protection from High-Intensity Radiation Fields (HIRF).

The GMA 245 is mounted using a GMA 245 unit rack (Figure 2-5). See [Section 3.6](#) for installation instructions.



### NOTE

*Rear support is recommended to ensure a sturdy mount.*



### CAUTION

*The top cover of the unit has a connector number (1 and 2) stamped into it and centered in front of each connector. The 011-00678-00 backplate also has a stamped number on it. To prevent damage to the unit, verify the connectors are positioned correctly (connector 1 is connected in position 1) for the number 1 and number 2 locations. The stamped number 1 refers to J2401, and 2 refers to J2402.*

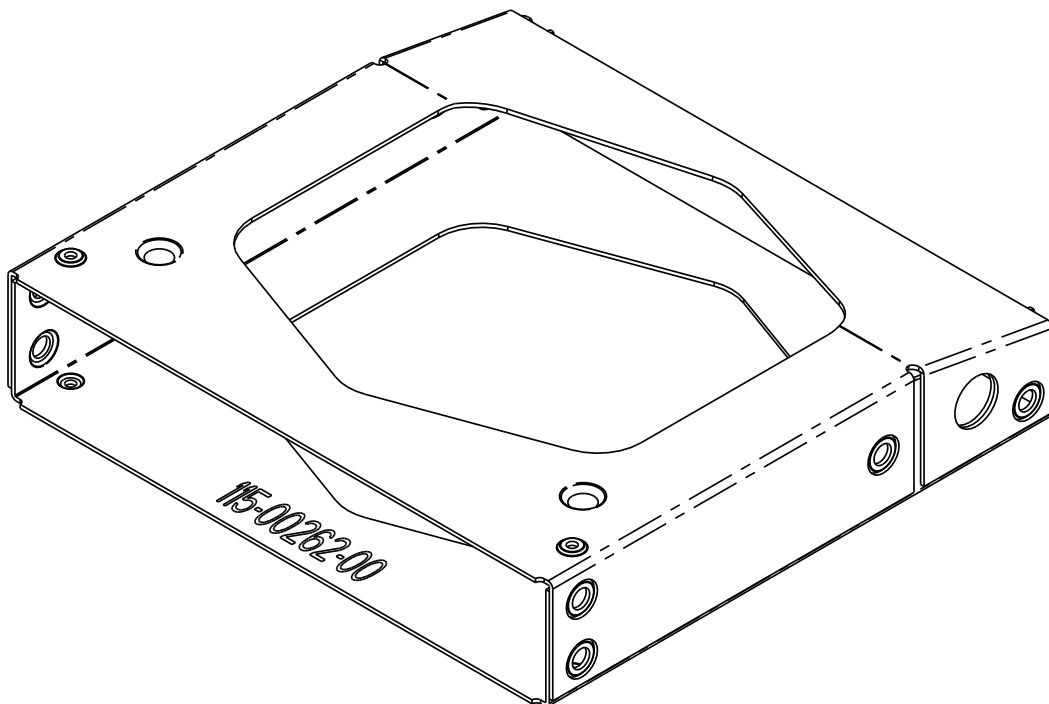

**Figure 2-5 GMA 245 Unit Rack (115-00262-00)**

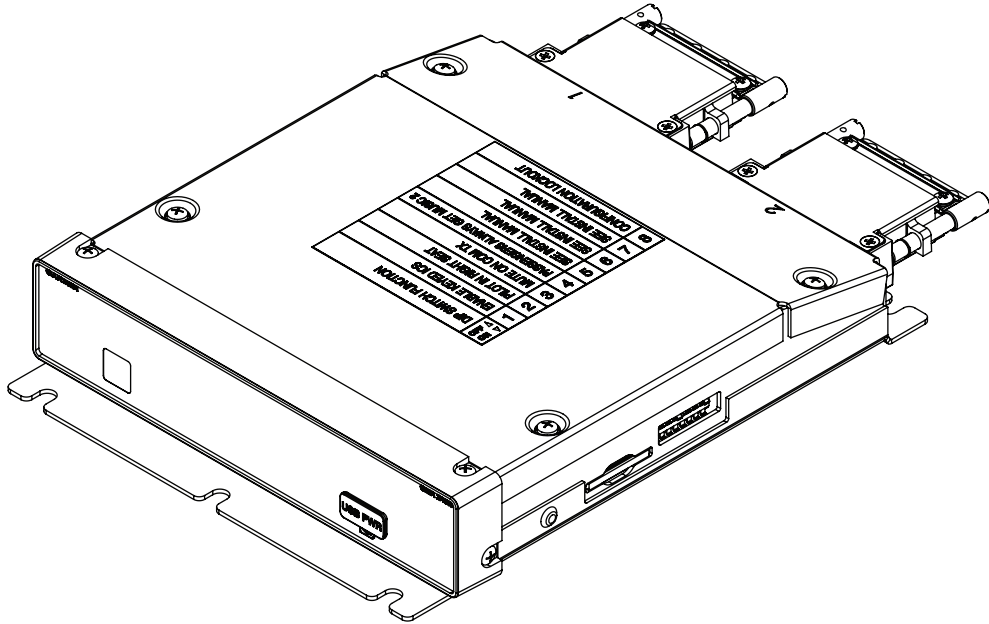

Figure 2-6 GMA 245R w/Mounting Brackets on Front and Back



**NOTE**

The GMA 245R is shipped in the configuration shown in Figure 2-6.

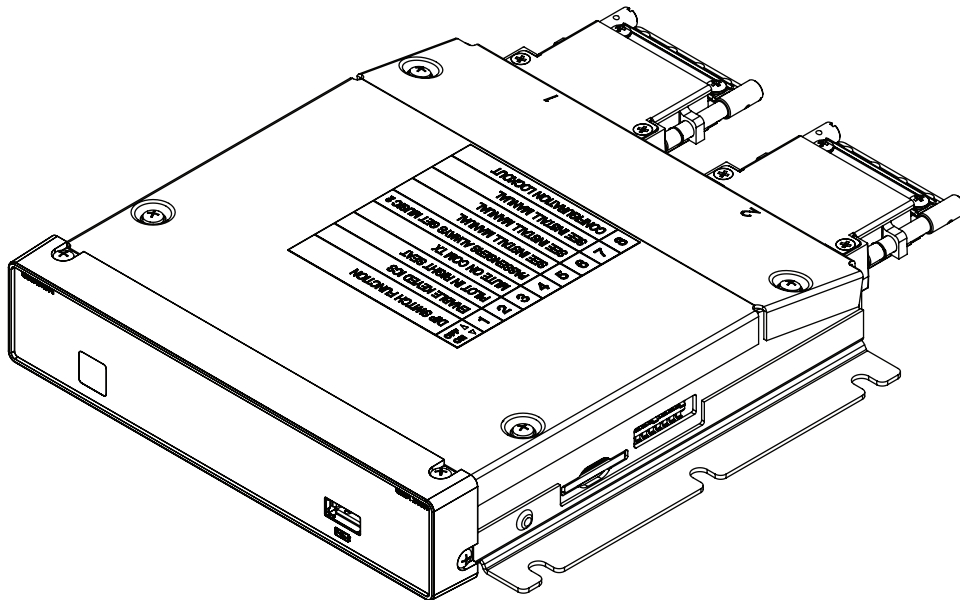

Figure 2-7 GMA 245R w/Mounting Brackets on Sides



**NOTE**

The side mounting bracket show in Figure 2-7 is an additional part included in the standard kit, and is also available as an optional accessory.

### 3 INSTALLATION PROCEDURE

#### 3.1 Unpacking Unit

Carefully unpack the equipment and make a visual inspection of the unit for evidence of damage incurred during shipment. If the unit is damaged, notify the carrier and file a claim. To justify a claim, save the original shipping container and all packing materials. Do not return the unit to Garmin until the carrier has authorized the claim.

Retain the original shipping containers for storage. If the original containers are not available, a separate cardboard container should be prepared that is large enough to accommodate sufficient packing material to prevent movement.

#### 3.2 Electrical Connections

All electrical connections to the GMA 245 are made through two 44-pin D-subminiature connectors (see [Figure 3-11](#)). [Section 4](#) defines the electrical characteristics of all input and output signals. Required connector and associated hardware are supplied in the connector kits. Refer to [Section 2.3](#) for the GMA 245 and GMA 245R standard kit part numbers that contain the necessary hardware. See [Appendix C](#) for interconnect wiring diagrams.



#### CAUTION

*Check wiring connections for errors before inserting the GMA 245 into the rack, or connecting the GMA 245R. Incorrect wiring could cause internal component damage.*

**Table 3-1 Pin Contact Part Numbers**

Manufacturer	44 pin D-Subminiature Connectors (P2401, P2402)	
	18-20 AWG (Power and Ground Only)	22-28 AWG
Garmin P/N	336-00044-00*	336-00021-00
Military P/N	N/A	M39029/58-360

\*Used for 18 AWG wire, is not included in the GMA 245/245R installation kits, and is not needed to install the GMA 245/245R. GPN 336-00021-00 is used for 22 AWG wire and is included in the GMA 245/245R installation kits. Use the 336-00044-00 if installing 18 AWG wire for Power and Ground.

**Table 3-2 Recommended Crimp Tools**

Manufacturer	Hand Crimping Tool	18-20 AWG		22-28 AWG	
		Positioner	Insertion/ Extraction Tool (Note 2)	Positioner	Insertion/ Extraction Tool
Military P/N	M22520/2-01	N/A	M81969/1-04	M22520/2-09	M81969/1-04
Positronic	9507	9502-11	M81969/1-04	9502-3	M81969/1-04
AMP	601966-1	N/A	91067-1	601966-6	91067-1
Daniels	AFM8	K774	M81969/1-04	K42	M81969/1-04
Astro	615717	N/A	M81969/1-04	615725	M81969/1-04



**NOTE**

1. Non-Garmin part numbers shown are not maintained by Garmin and consequently are subject to change without notice.
2. Extracting #18 and #20 contacts requires that the expanded wire barrel be cut off from the contact. It may also be necessary to push the pin out from the face of the connector when using an extractor due to the absence of the wire. A new contact must be used when reassembling the connector.

### 3.3 Jackscrew and Shield Block Backshell Installation Instructions

#### 3.3.1 Backshell Installation Parts

Table 3-3 and [Table 3-5](#) list the parts needed to install a Jackscrew Backshell (GMA 245R), the item numbers in these tables correspond to [Figure 3-1](#). [Table 3-4](#) and [Table 3-5](#) list the parts needed to install a Shield Block Backshell (GMA 245). The item numbers in these tables correspond to [Figure 3-2](#). Parts listed in Table 3-5 are to be provided by the installer.

The items listed in Table 3-3 are provided in the GMA 245R Connector Kit ([Table 2-9](#)).

**Table 3-3 Parts supplied for a GMA 245R Jackscrew Backshell Installation ([Figure 3-1](#))**

Item #	Description	GPN
1	Jackscrew Backshell	125-00173-00
6	Contact Pin, Mil Crimp, Size 22D	336-00021-00
8	Screw, 8-32x.312, PHP, SS/P	211-60209-09
9	Wshr, Split Lock, Size 8	212-00018-04
10	Wshr, Flat, Non-Std, SS, ID.195, OD.354	212-20065-00
12	Clamp	115-01078-02
13	Screw, 4-40x.375, PHP, SS/P, w/Nylon	211-60234-10
14	Cover	115-01079-02
15	Screw, 4-40x.187, FLHP100, SS/P, w/Nylon	211-63234-06
16	Hi Density D-Sub Connector, Mil Crimp, 44 ckt	330-00185-44

The items listed in Table 3-4 are provided in the GMA 245 Connector Kit ([Table 2-6](#) and [Table 2-7](#)).

**Table 3-4 Parts supplied for a GMA 245 Backshell Installation ([Figure 3-2](#))**

Item #	Description	GPN
1	Cast Backshell Housing	125-00083-00
6	Contact Pin, Mil Crimp, Size 22D	336-00021-00
8	Screw, 8-32x.312, PHP, SS/P	211-60209-09
9	Wshr, Split Lock, Size 8	212-00018-04
10	Wshr, Flat, Non-Std, SS, ID.195, OD.354	212-20065-00
12	Clamp	115-00499-02
13	Screw, 4-40x.375, PHP, SS/P, w/Nylon	211-60234-10
14	Cover	115-00500-02
15	Screw, 4-40x.375, PHP, SS/P, w/Nylon	211-63234-06
16	Hi Density D-Sub Connector, Mil Crimp, 44 ckt	330-00185-44
17*	Screw, 4-40x.250, FLHP100, SS/P	211-63234-08
18*	Adapter, Ring Terminal, Shell SZ 1,2	117-00147-00
19*	Screw, 4-40x.437, FLHP100, SS/P, Nylon	211-63234-11

\*GMA 245 Shield Block Backshell only

**Table 3-5 Parts not supplied for a Backshell Installation ([Figure 3-1](#))**

Item #	Description	GPN or MIL spec
2	Multiple Conductor Shielded Cable (2-conductor shown in <a href="#">Figure 3-1</a> )	Parts used depend on method chosen
3	Drain Wire Shield Termination (method optional)	Parts used depend on method chosen
4	Braid, Flat (19-20 AWG equivalent, tinned plated copper strands 36 AWG, Circular Mil Area 1000 -1300)	Parts used depend on method chosen
5	Floating Shield Termination (method optional)	Parts used depend on method chosen
7	Ring terminal, #8, insulated, 18-22 AWG	MS25036-149
	Ring terminal, #8, insulated, 14-16 AWG	MS25036-153
	Ring terminal, #8, insulated, 10-12 AWG	MS25036-156
11	Silicone Fusion Tape	-



**NOTE**

*In Figure 3-1, “AR” denotes quantity “As Required” for the particular installation.*

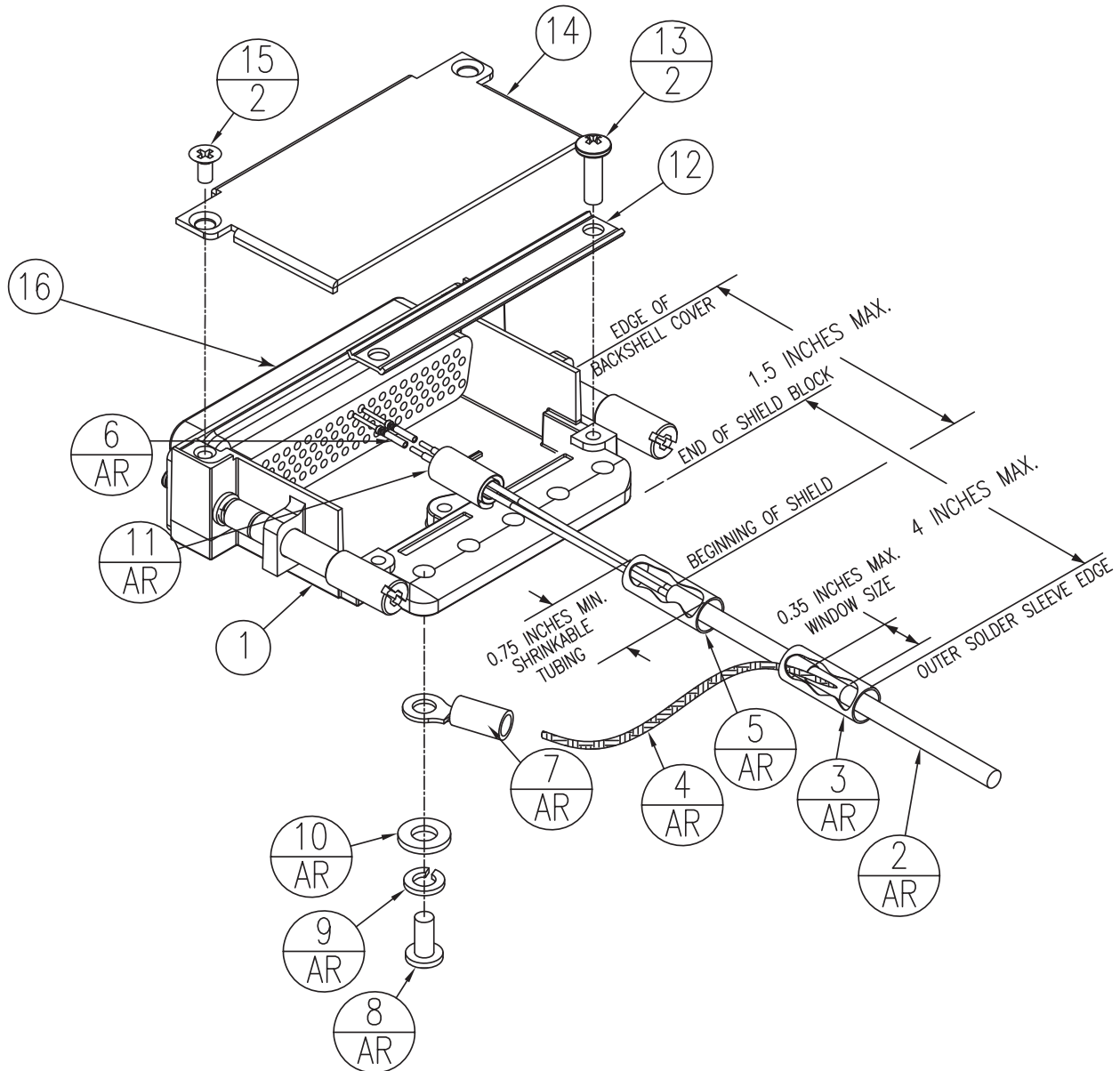

**Figure 3-1 GMA 245R Jackscrew Backshell Assembly**



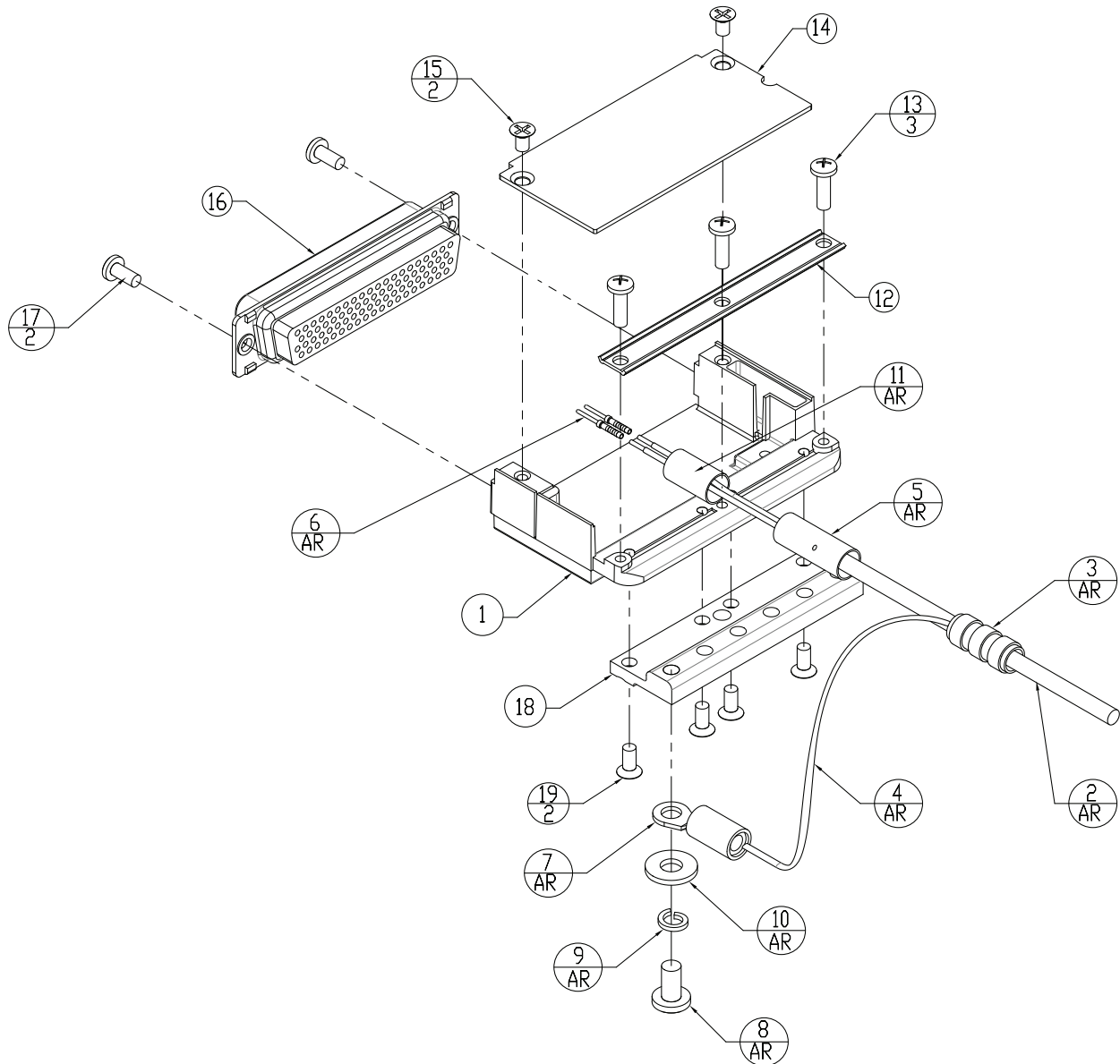

Figure 3-2 GMA 245 Shield Block Backshell Assembly

**3.3.2 Shield Termination Technique – Method A.1 (Standard)**



**NOTE**

For the following steps please refer to [Figure 3-1](#) or [Figure 3-2](#) (as appropriate), and [Figure 3-3](#).

1. The appropriate number of Backshells will be included in the particular LRU connector kit.

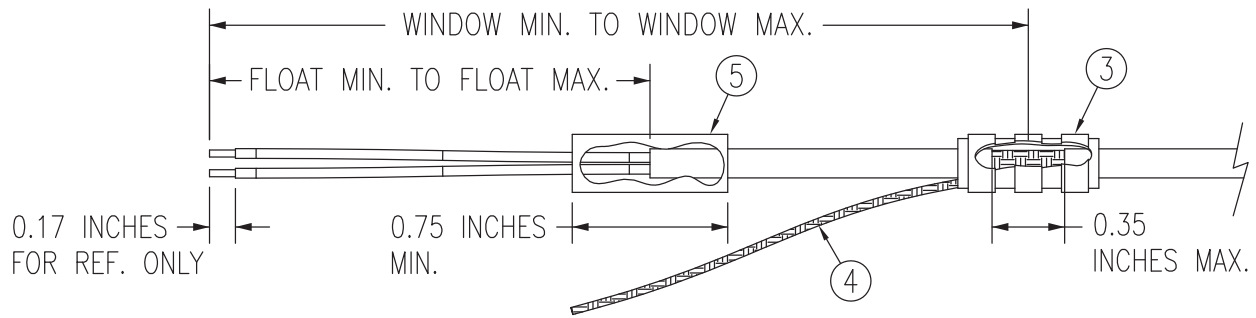

**Figure 3-3 Method A.1 for Shield Termination**

**Table 3-6 Shielded Cable Preparations for Garmin Connectors**

Backshell-Size	Number of Pins Std/HD	Float Min (inches)	Float Max (inches)	Ideal Float (inches)	Window Min (inches)	Window Max (inches)	Ideal Window (inches)
44 Pin	44	1.5	2.5	2.0	3.0	5.5	4.5

2. At one end of a shielded cable (item 2, [Figure 3-1](#) or [Figure 3-2](#)) measure a distance between “Window Min” to “Window Max” (Table 3-6) and cut a window (max size 0.35”) in the jacket to expose the shield (item 4, Figure 3-3). Use caution when cutting the jacket to avoid damaging the individual braids of the shield. When dealing with a densely populated connector with many cables, it may prove beneficial to stagger the windows throughout the “Window Min” to “Window Max” range. If staggering is not needed the “Ideal Window” length is recommended.

Suggested tools to accomplish the window cut:

- Coaxial Cable Stripper
- Thermal Stripper
- Sharp Razor Blade

3. Connect a Flat Braid (item 4, [Figure 3-3](#)) to the shield exposed through the window of the prepared cable assembly (item 2, [Figure 3-1](#) or [Figure 3-2](#)) from step 2. The Flat Braid should go out the front of the termination towards the connector. It is not permitted to exit the rear of the termination and loop back towards the connector ([Figure 3-3](#)). Make this connection using an approved shield termination technique.



#### NOTE

*FAA AC 43.13-1B Chapter 11, Section 8 (Wiring Installation Inspection Requirements) may be a helpful reference for termination techniques.*

#### **Preferred Method:**

Slide a solder sleeve (item 3, [Figure 3-1](#) or [Figure 3-2](#)) onto the prepared cable assembly (item 2, [Figure 3-1](#) or [Figure 3-2](#)) and connect the Flat Braid (item 4, [Figure 3-3](#)) to the shield using a heat gun approved for use with solder sleeves. It may prove beneficial to use a solder sleeve with a pre-installed Flat Braid versus having to cut a length of Flat Braid to be used. The chosen size of solder sleeve must accommodate both the number of conductors present in the cable and the Flat Braid (item 4, [Figure 3-3](#)) to be attached.

#### **Solder Sleeves with pre-installed Flat Braid**

A preferred solder sleeve would be the Raychem S03 Series with the thermochromic temperature indicator (S03-02-R-9035-100, S03-03-R-9035-100, S03-04-R-9035-100). These solder sleeves come with a pre-installed braid and effectively take the place of items 3 and 4, [Figure 3-3](#). For detailed instructions on product use, reference Raychem installation procedure RCPS 100-70.

#### Raychem recommended heating tools:

- HL1802E
- AA-400 Super Heater
- CV-1981
- MiniRay
- IR-1759

#### **Individual solder sleeves and Flat Braid**

##### Solder Sleeves:

Reference the following MIL-Specs for solder sleeves.

(M83519/1-1, M83519/1-2, M83519/1-3, M83519/1-4, M83519/1-5)

##### Flat Braid:

If the preferred Raychem sleeves are not being used, the individual flat braid selected should conform to ASTM B33 for tinned copper and be made up of 36 AWG strands to form an approximately 19-20 AWG equivalent flat braid. A circular mil area range of 1000 to 1300 is required. The number of individual strands in each braid bundle is not specified. (e.g. QQB575F36T062)



#### NOTE

*Flat Braid as opposed to insulated wire is specified in order to allow continuing air worthiness by allowing for visual inspection of the conductor.*

**Secondary Method:**

Solder a Flat Braid (item 4, [Figure 3-3](#)) to the shield exposed through the window of the prepared cable assembly (item 2, [Figure 3-1](#) or [Figure 3-2](#)). Ensure a solid electrical connection through the use of acceptable soldering practices. Use care to avoid applying excessive heat that burns through the insulation of the center conductors and shorts the shield to the signal wire. Slide a minimum 0.75 inches of heat shrinkable tubing (item 3, [Figure 3-3](#)) onto the prepared wire assembly and shrink using a heat gun. The chosen size of heat shrinkage tubing must accommodate both the number of conductors present in the cable and the Flat Braid (item 4, [Figure 3-3](#)) to be attached.

**Heat Shrinkable Tubing:**

Reference the following MIL-Spec for heat shrinkable tubing (M23053/5-X-Y).

- At the same end of the shielded cable (item 2, [Figure 3-1](#) or [Figure 3-2](#)) and ahead of the previous shield termination, strip back “Float Min” to “Float Max” ([Table 3-6](#)) length of jacket and shield to expose the insulated center conductors ([Figure 3-3](#)). The “Ideal Float” length may be best to build optimally.

**Preferred Method:**

The jacket and shield should be cut off at the same point so no shield is exposed. Slide 0.75 inches minimum of heat shrinkable tubing (item 5, [Figure 3-3](#)) onto the cable and use a heat gun to shrink the tubing. The chosen size of heat shrinkage tubing must accommodate the number of conductors present in the cable.

**Secondary Method:**

Leave a max 0.35 inches of shield extending past the jacket. Fold this 0.35 inches of shield back over the jacket. Slide a solder sleeve (item 5, [Figure 3-3](#)) over the end of the cable and use a heat gun approved for solder sleeves to secure the connection. The chosen size of solder sleeve must accommodate the number of conductors present in the cable.

- Strip back approximately 0.17 inches of insulation from each wire of the shielded cable (item 2, [Figure 3-4](#)) and crimp a contact (item 6, [Figure 3-4](#)) to each conductor. It is the responsibility of the installer to determine the proper length of insulation to be removed. Wire must be visible in the inspection hole after crimping and the insulation must be 1/64 – 1/32 inches from the end of the contact as shown in [Figure 3-4](#).

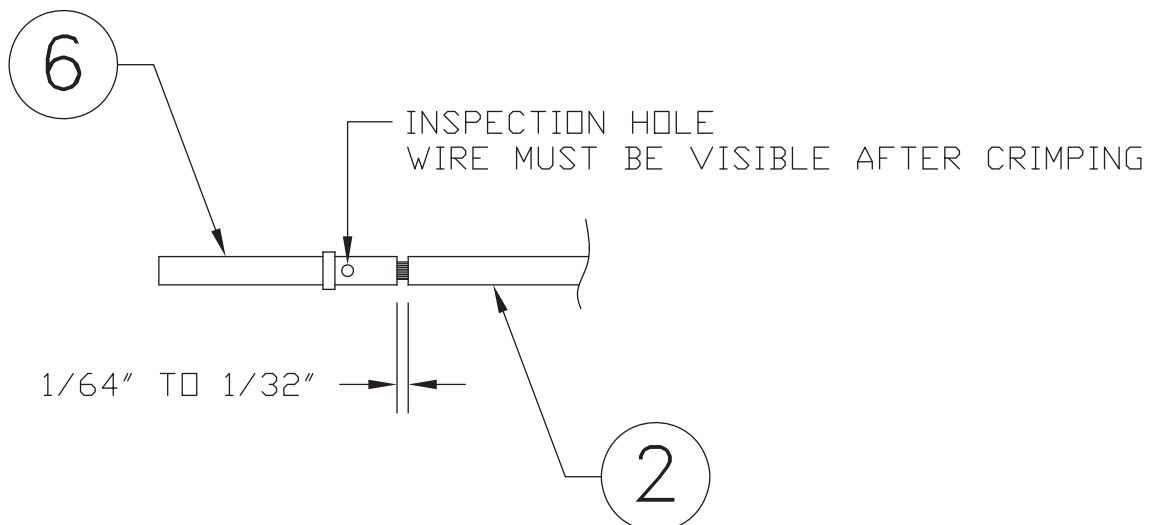

**Figure 3-4 Insulation/Contact Clearance**



### NOTE

*For the item numbers in the following steps 6-13 please refer to [Figure 3-1](#), or [Figure 3-2](#) as appropriate.*

6. Insert newly crimped pins and wires into the appropriate connector housing location as specified by the installation wiring diagrams.
7. Cut the Flat Braid (item 4) to a length that, with the addition of a ring terminal, will reach one of the tapped holes of the Jackscrew backshell (item 1). An appropriate amount of excess length without looping should be given to the Flat Braid (item 4) to allow it to freely move with the wire bundle.



### NOTE

*Position the window splice to accommodate a Flat Braid (item 4) length of no more than 4 inches.*

8. Guidelines for terminating the newly cutoff Flat Braid(s) (item 4) with insulated ring terminals (item 7):
  - Each tapped hole on the Jackscrew Backshell (item 1) may accommodate only two ring terminals (item 7).
  - It is preferred that only two Flat Braid(s) (item 4) be terminated per ring terminal. Two Flat Braids per ring terminal will necessitate the use of a Ring terminal, #8, insulated, 14-16 AWG (MS25036-153).
  - If only a single Flat Braid is left or if only a single Flat Braid is needed for this connector a Ring terminal, #8, insulated, 18-22 AWG (MS25036-149) can accommodate this single Flat Braid.
  - If more braids exist for this connector than two per ring terminal, it is permissible to terminate three braids per ring terminal. This will necessitate the use of a Ring terminal, #8, insulated, 10-12 AWG (MS25036-156).
9. Repeat steps 2 through 8 as needed for the remaining shielded cables.
10. Terminate the ring terminals to the Jackscrew Backshell (item 1) by placing items on the Pan Head Screw (item 8) in the following order: Split Washer (item 9), Flat Washer (item 10) first Ring Terminal, second Ring Terminal (if needed) before finally inserting the screw into the tapped holes on the Jackscrew Backshell. Do not violate the guidelines presented in Step 8 regarding ring terminals.
11. It is recommended to wrap the cable bundle with Silicone Fusion Tape (item 11) (GPN: 249-00114-00 or a similar version) at the point where the backshell clamp and cast housing will contact the cable bundle.



### NOTE

*Choosing to use this tape is the discretion of the installer.*

12. Place the smooth side of the backshell clamp (item 12) across the cable bundle and secure using the three screws (item 13). Warning: Placing the grooved side of the clamp across the cable bundle may risk damage to wires.
13. Attach the cover (item 14) to the backshell (item 1) using the two screws (item 15).

### 3.3.3 Shield Termination Technique - Method A.2 (Daisy Chain)

In rare situations where more braids need to be terminated for a connector than three per ring terminal it is allowable to daisy chain a maximum of two shields together before coming to the ring terminal (Figure 3-5). All other restrictions and instructions for the shield termination technique set forth for Method A.1 are still applicable.



**NOTE**

*The maximum length of the combined braids should be approximately 4 inches.*

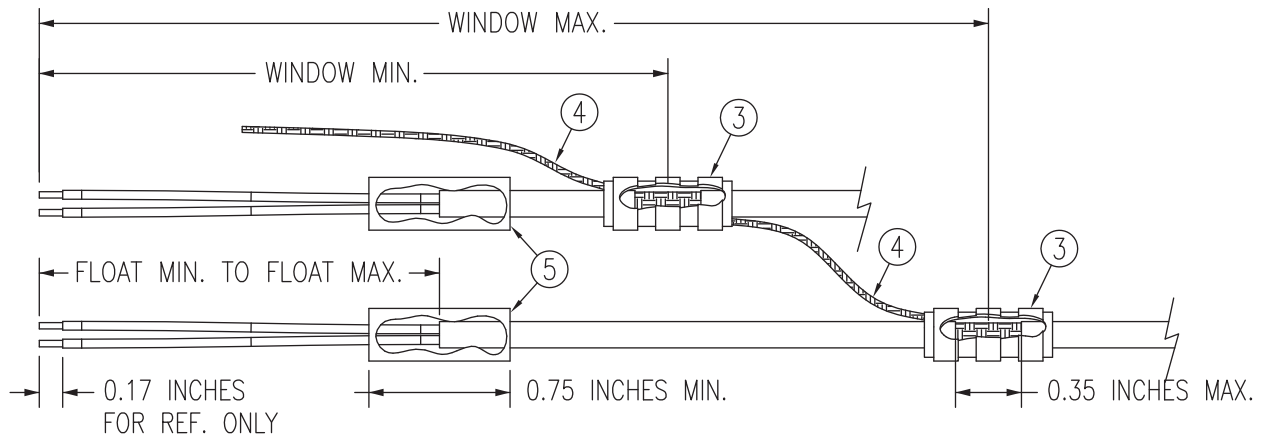

**Figure 3-5 Method A.2 (Daisy Chain) for Shield Termination**

### 3.3.4 Shield Termination – Method B.1 (Quick Term)

If desired, the drain wire termination (item 3, [Figure 3-5](#)) and the floating shield termination (item 5, [Figure 3-5](#)) can be effectively combined into a “Quick Term”. This method eliminates the float in the cable insulation and moves the placement of the window which was described by the dimensions “Window Min” and “Window Max” from Method A. This technique is depicted in [Figure 3-6](#).



#### NOTE

*The original purpose for separating the shield drain termination (item 3, [Figure 3-5](#)) from the float termination (item 5, [Figure 3-5](#)) in Method A was to allow for a variety of lengths for the drain wires so that the shield drain terminations (item 3, [Figure 3-5](#)) would not all “bunch up” in the harness and to eliminate loops in the drain wires. If Method B is chosen, as described in this section, care must be taken to ensure that all drain shield terminations can still be inspected. With connectors which require a large number of shield terminations it may be best to use Method A. This will allow the drain shield terminations (item 3, [Figure 3-5](#)) a larger area to be dispersed across.*

Using this method, the instructions from [Section 3.3.2](#) (Method A) are followed except that:

1. Step 2 is eliminated
2. Steps 3 and 4 are replaced by the following:  
At the end of the shielded cable (item 2, [Figure 3-1](#) or [Figure 3-2](#)), strip “Quick Term Min” to “Quick Term Max” ([Table 3-7](#)) length of the jacket to expose the shield. Next trim the shield so that at most 0.35 inches remains extending beyond the insulating jacket. Fold this remaining shield back over the jacket.

Connect a Flat Braid (item 4, [Figure 3-1](#) or [Figure 3-2](#)) to the folded back shield of the prepared cable assembly. The flat braid should go out the front of the termination towards the connector. It is not permitted to exit the rear of the termination and loop back towards the connector ([Figure 3-6](#)). Make this connection using an approved shield termination technique.



#### NOTE

*FAA AC 43.13-1B Chapter 11, Section 8 (Wiring Installation Inspection Requirements) may be a helpful reference for termination techniques.*

#### Preferred Method:

Slide a solder sleeve (item 3, [Figure 3-1](#) or [Figure 3-2](#)) onto the prepared cable assembly (item 2, [Figure 3-1](#), or [Figure 3-2](#)) and connect the Flat Braid (item 4, [Figure 3-1](#) or [Figure 3-2](#)) to the shield using a heat gun approved for use with solder sleeves. It may prove beneficial to use a solder sleeve with a pre-installed Flat Braid versus having to cut a length of Flat Braid to be used. The chosen size of solder sleeve must accommodate both the number of conductors present in the cable and the Flat Braid (item 4, [Figure 3-1](#) or [Figure 3-2](#)) to be attached.



#### NOTE

*Reference [Section 3.3.2](#) for recommended solder sleeves and flat braid. The same recommendations are applicable to this technique.*

Secondary Method:

Solder a Flat Braid (item 4, Figure 3-6) to the folded back shield on the prepared cable assembly (item 2, [Figure 3-1](#) or [Figure 3-2](#)). Ensure a solid electrical connection through the use of acceptable soldering practices. Use care to avoid applying excessive heat that burns through the insulation of the center conductors and shorts the shield to the signal wire. Slide a minimum of 0.75 inches of heat shrinkable tubing (item 3, Figure 3-6) onto the prepared wire assembly and shrink using a heat gun. The chosen size of heat shrinkage tubing must accommodate both the number of conductors present in the cable as well as the Flat Braid (item 4, Figure 3-6) to be attached.

Heat Shrinkable Tubing:

Reference the following MIL-Spec for general heat shrinkable tubing (M23053/5-X-Y)

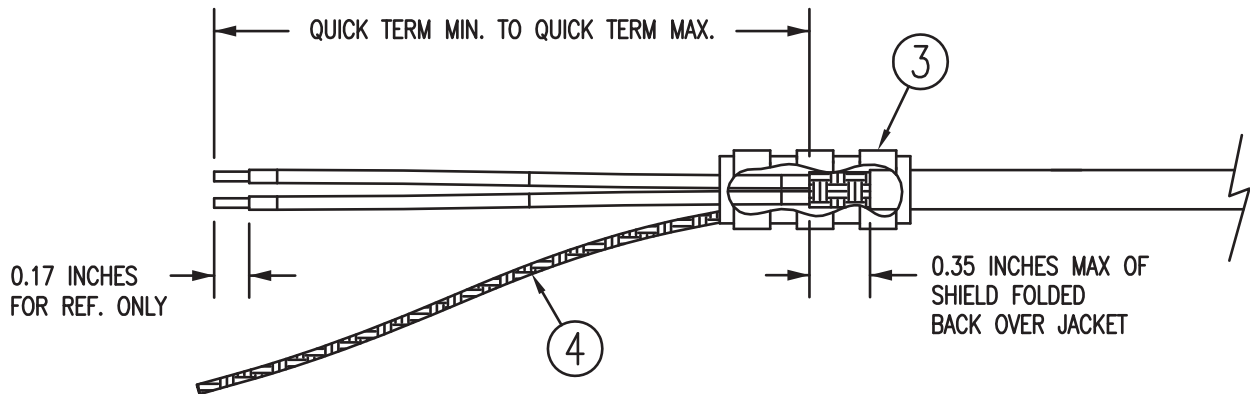

**Figure 3-6 Method B.1 (Quick Term) for Shield Termination**

**Table 3-7 Shielded Cable Preparations – (Quick Term)**

Backshell Size	Number of Pins Std/HD	Quick Term Min (inches)	Quick Term Max (inches)	Quick Term Float (inches)
44 Pin	44	1.5	2.5	2.0



### 3.3.5 Shield Termination-Method B.2 (Daisy Chain-Quick Term)

In rare situations where more braids need to be terminated for a connector than three per ring terminal it is allowable to daisy chain a maximum of two shields together before coming to the ring terminal (Figure 3-7). All other restrictions and instructions for the shield termination technique set forth for Method B.1 are still applicable.



**NOTE**

*The maximum length of the combined braids should be approximately 4 inches.*

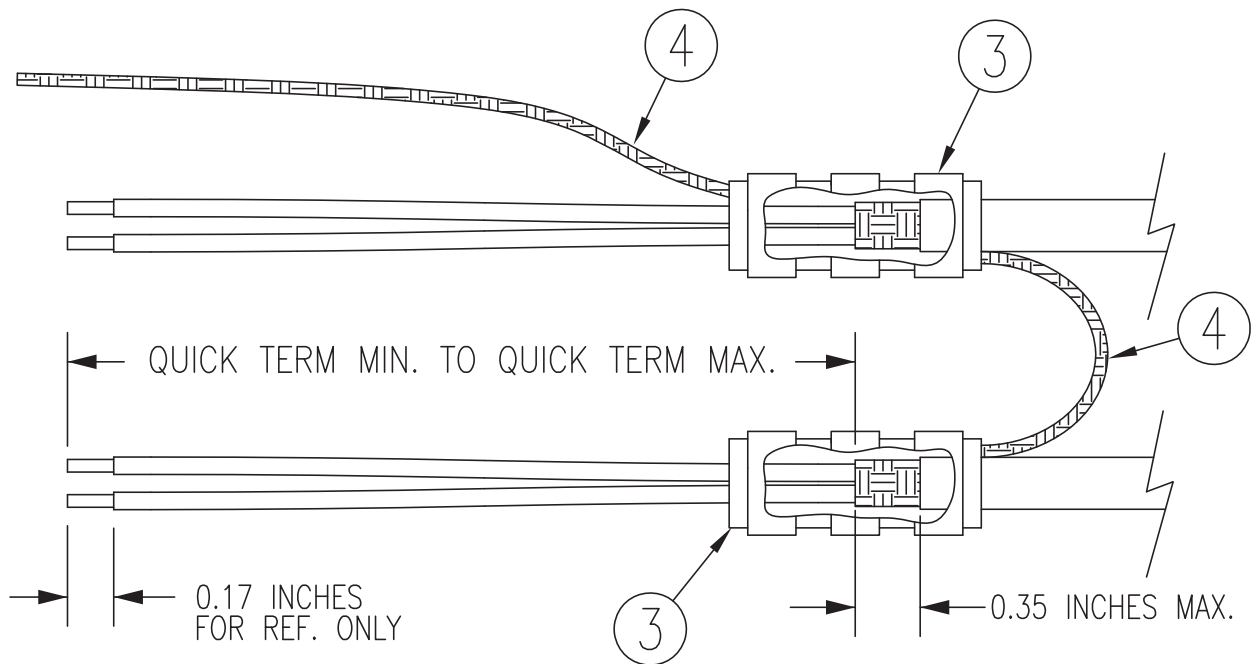

**Figure 3-7 Method B.2 (Daisy Chain-Quick Term) for Shield Termination**

### 3.3.6 Daisy Chain between Methods A and B

In rare situations where more braids need to be terminated for a connector than three per ring terminal and a mixture of Methods A and B have been used, it is allowable to daisy chain a maximum of two shields together from a Method A termination to a Method B (Figure 3-8). All other restrictions and instructions for the shield termination technique set forth for Method A and B are still applicable.



**NOTE**

*The maximum length of the combined braids should be approximately 4 inches.*

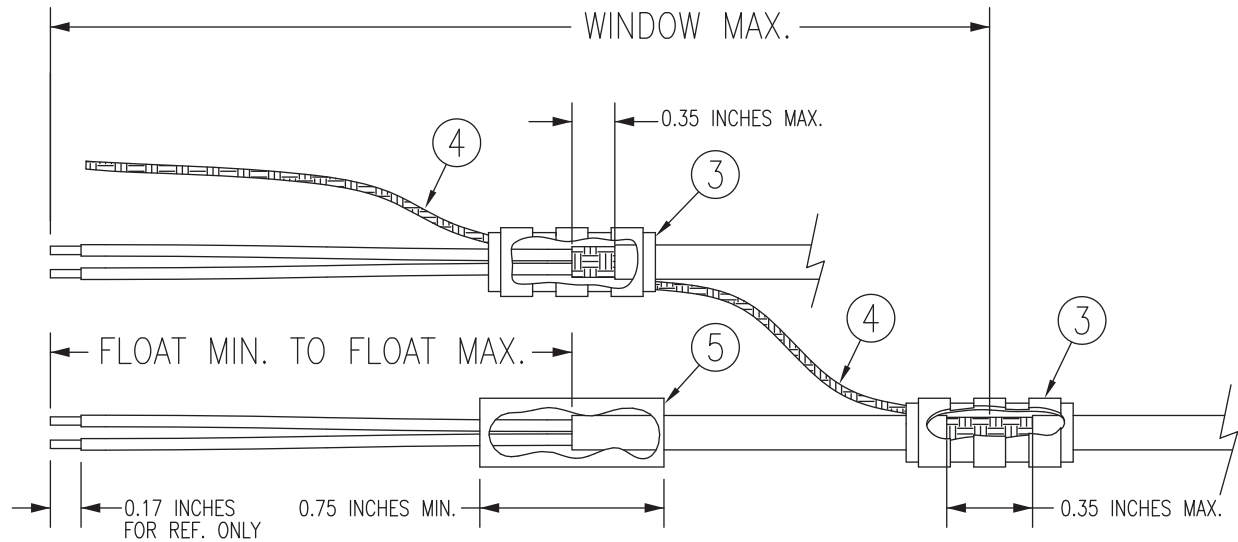

**Figure 3-8 Daisy Chain between Methods A and B**

### 3.3.7 Splicing Signal Wires

Refer to Figure 3-9 for GMA 245R installations, or to [Figure 3-10](#) for GMA 245 installations.



**NOTE**

*Figure 3-9 and [Figure 3-10](#) illustrate that a splice must be made within a 3 inch window from outside the edge of clamp to the end of the 3 inch max mark.*



**WARNING**

*Keep the splice out of the backshell for pin extraction, and outside of the strain relief to avoid preloading.*

Figure 3-9 and [Figure 3-10](#) show a two wire splice, but a maximum of three wires can be spliced. If a third wire is spliced, it is located out front of splice along with signal wire going to pin.

Splice part numbers:

- Raychem D-436-36/37/38
- MIL Spec MIL-S-81824/1

This technique may be used with shield termination methods: A.1, A.2, B.1, B.2, C.1 and C.2.

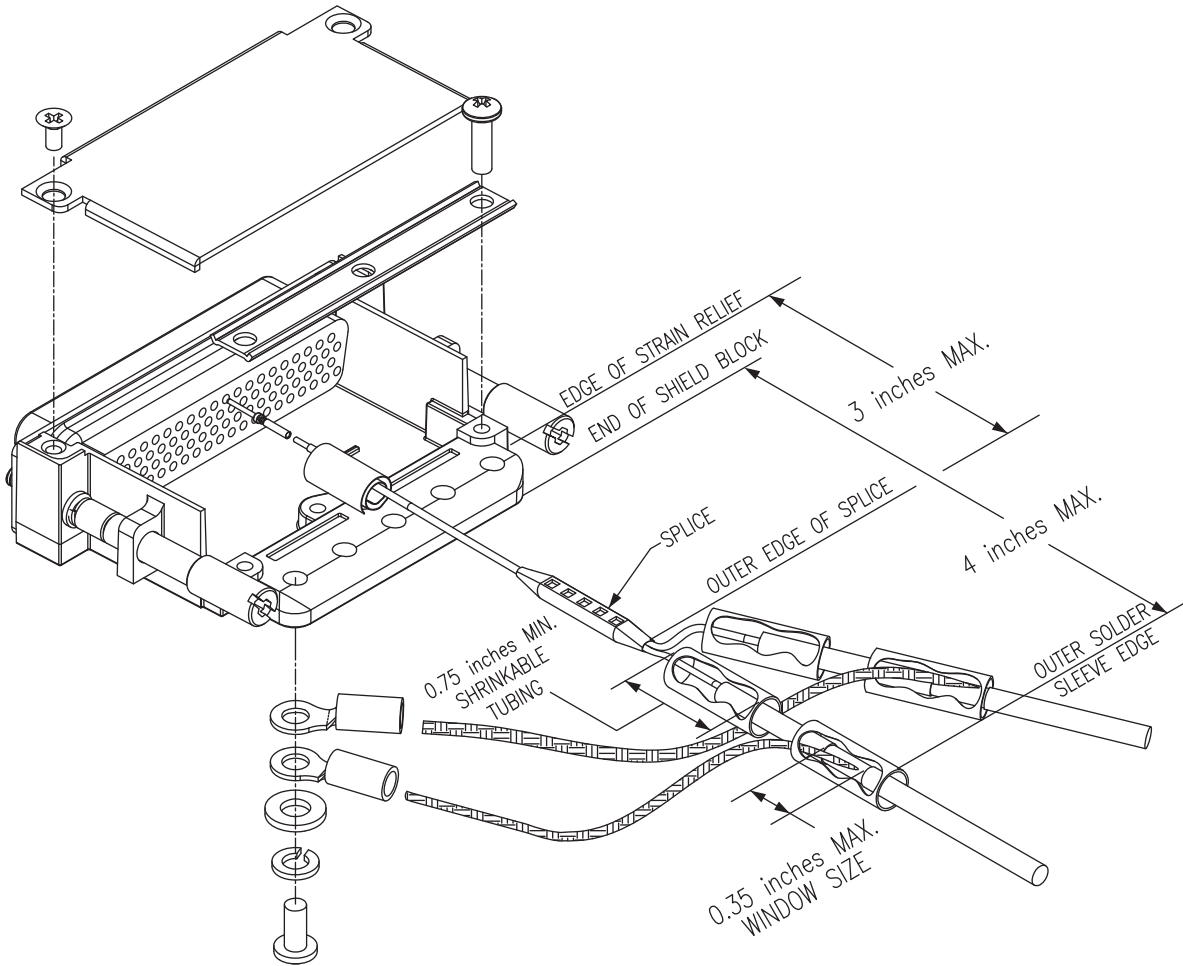

**Figure 3-9 Jackscrew D-Sub Spliced Signal Wire illustration**

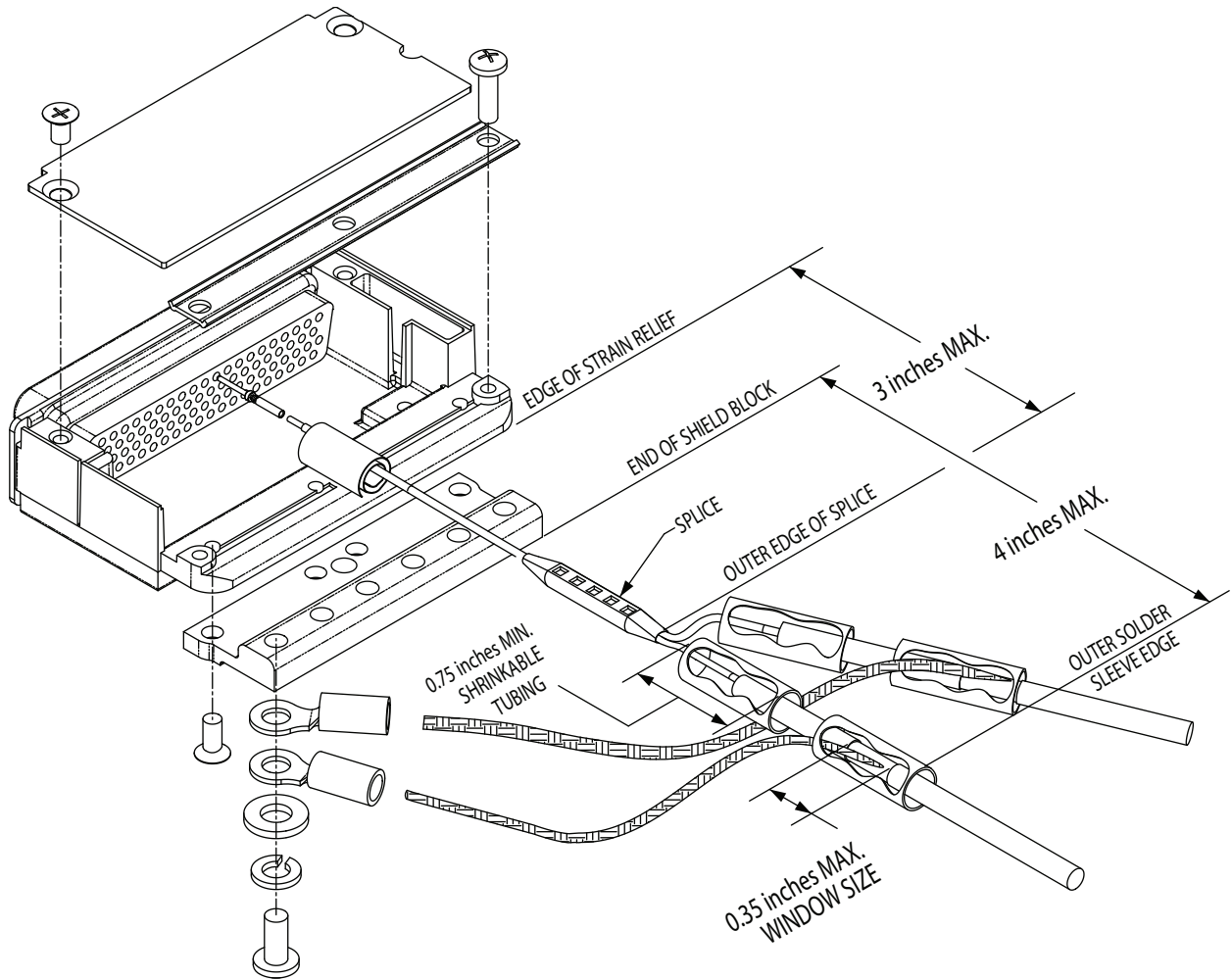

**Figure 3-10 Shield Block D-Sub Spliced Signal Wire illustration**

### 3.4 Backshell Assembly

The GMA 245 connector kit includes two Garmin backshell assemblies. Garmin’s backshell connectors give the installer the ability to quickly and easily terminate shield grounds at the backshell housing using the Shield Block. To assemble the backshell connectors and grounding system, refer to instructions provided in the [Section 3.3](#).

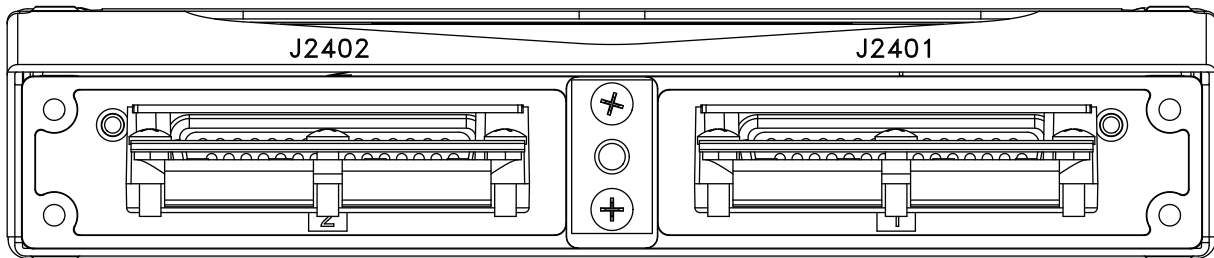

Figure 3-11 Rear View of Rack and Connectors

### 3.5 Audio Shield Termination

For audio shield terminations, the cable shield terminations should be tied to the backshell using ring terminals and the supplied #8 screws with lock and flat washer per [Figure 3-12](#) and [Figure 3-13](#).

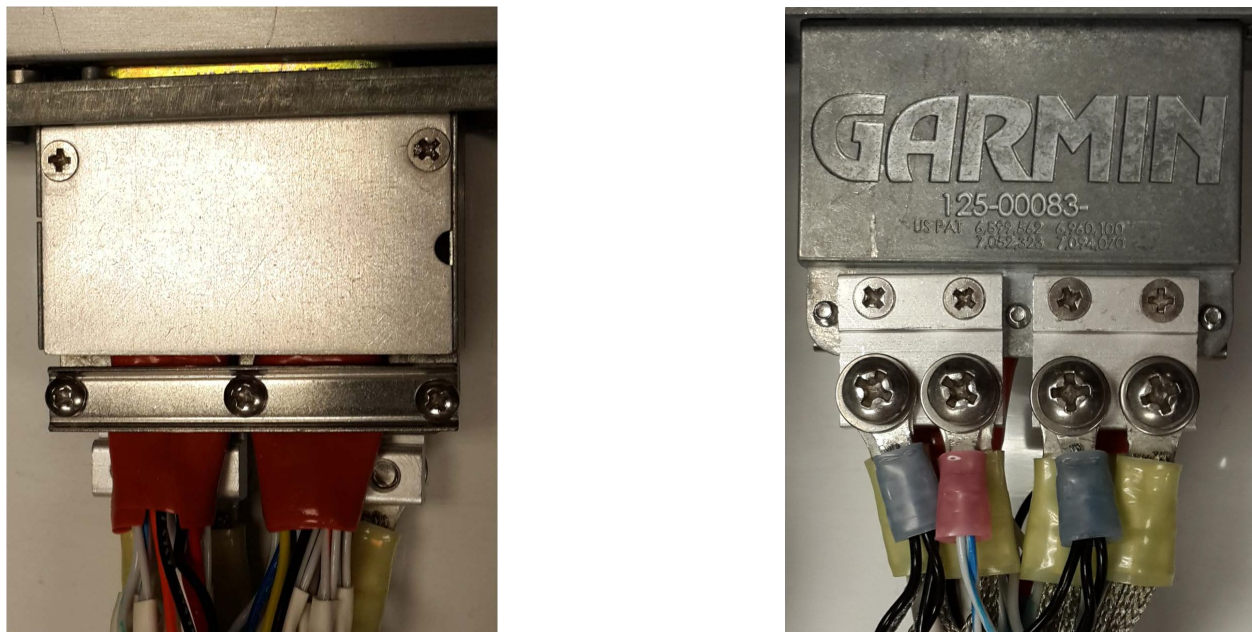

Figure 3-12 GMA 245 Audio Shield Termination (top and bottom)

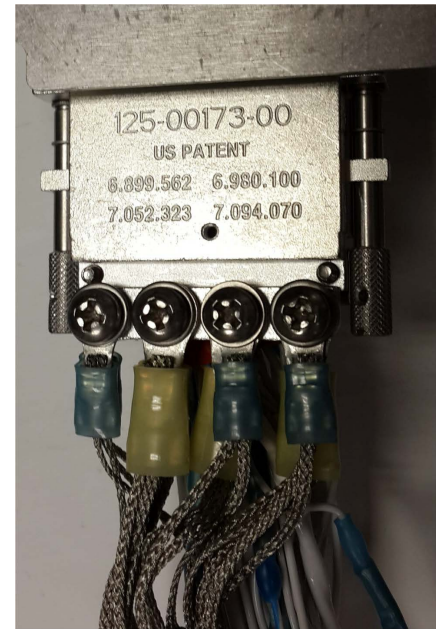
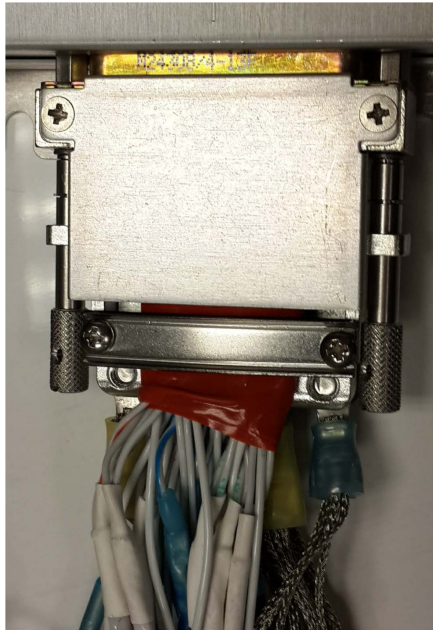

Figure 3-13 GMA 245R Audio Shield Termination (top and bottom)

### 3.6 Unit Installation



#### CAUTION

*Do not use excessive force when inserting the GMA 245 into the rack. This may damage the connectors, unit, and/or rack. If heavy resistance is felt during installation, stop! Remove the GMA 245 and identify the source of resistance.*

#### 3.6.1 GMA 245 Installation:

For final installation and assembly, refer to the outline and installation drawings [Figure B-1](#) and [Figure B-2](#)

1. Assemble the backshell as described in [Section 3.4](#).
2. Connect both backshells to the rear plate using the screws provided in the connector kit ([Figure B-2](#)).
3. Mount the GMA 245 rack to the GMA rack as shown on the installation drawing.
4. Assemble the rear plate into the GMA 245 unit rack.
5. Insert the GMA 245 into the rack, noting proper orientation as shown on the installation drawing.
6. Lock the GMA 245 in place using a 3/32" Allen tool.

#### 3.6.2 GMA 245R Installation:

For final installation and assembly, refer to the outline and installation drawings [Figure B-3](#), [Figure B-4](#), and [Figure B-5](#).

1. Assemble the GMA 245R in either the end mount bracket ([Figure B-4](#)) or side mount bracket ([Figure B-5](#)) configuration.
2. Assemble the backshell as described in [Section 3.4](#).
3. Connect both backshells to the rear plate using the screws provided in the connector kit ([Figure B-3](#)).
4. Mount the GMA 245R using a minimum of four #10 fasteners (not provided).

### 3.7 Post Installation Checkout



#### CAUTION

*Check wiring connections for errors before inserting the GMA 245 into the rack. Incorrect wiring could cause internal component damage.*

An in-aircraft checkout may be performed in the aircraft on the ramp with known good microphone, headset, and avionics receivers.

#### 3.7.1 Failsafe Operation Check

1. Remove power to the unit by pulling the GMA 245 breaker.
2. Connect a mono headset to the pilot's headset output jack and pilot's mic jack.



#### NOTE

*Use of a true mono headset is required for this test to ensure proper wiring even if a stereo jack is provided in the installation. Wiring left channel (tip contact) and right channel (ring contact) backwards will cause failsafe mode not to function with mono headsets. Use of a true mono headset is required for this test (not a stereo headset with a mono/stereo switch because headset manufactures differ on how they accomplish this switching). This will guarantee the condition of the right channel (ring terminal) being shorted to the return (sleeve terminal) by the mono headset's plug. This short occurs because of the physical design of the headset plug contacts and is an inevitable consequence of plugging a mono headset into a stereo jack. During power-on operation, this short will not damage the audio panel.*

3. Verify that COM1 transceiver can be heard in the pilot's headset.
4. Verify that COM1 can key and transmit the pilot's mic audio by verifying received sidetone or checking reception of the transmission with another radio tuned to receive this transmission (verify Pilot PTT and mic operation is delivered to this transceiver).
5. Apply unit power by restoring the audio breaker to the normal operating position

#### 3.7.2 Transceiver Operational Check

1. Perform a ramp test radio check by exercising the installed transceivers, microphone, microphone key, and audio over the headphone.
2. Verify that communications are loud and clear and PTT operation is correct.

#### 3.7.3 Intercom System (ICS) Check



#### NOTE

*Stereo headsets are recommended if stereo jacks are installed. If a monaural headset is used in a stereo jack, the audio panel's right channel output is shorted to ground by the mono headset's plug (the audio panel automatically detects the short and turns off the right channel). In the case of passenger positions wired in parallel, any stereo listener will lose right channel audio when another passenger plugs in a mono headset.*

1. Set the intercom to the ALL mode [Pilot and Crew LED off.]
2. Plug in headsets at each ICS position.
3. Check Pilot and Copilot ICS positions for isolation and proper operation of volume controls.

### 3.7.4 Aircraft Receivers Check

1. Select the audio source corresponding to each installed avionics unit and check for audio over the headsets.

### 3.7.5 Music System Check

1. Set GMA to ALL mode with Pilot and Crew keys off.
2. Connect a stereo audio source to MUSIC 1. Verify that stereo audio is heard over all headset positions when MUSIC 1 is selected as the music source and MUSIC LED is on. Verify that music volume adjustment is working properly for Pilot and Copilot/Passengers (if passenger headsets are wired).
3. Connect a stereo music source to MUSIC 2. Verify that stereo audio is heard when MUSIC 2 is selected as the music source and MUSIC LED is on.

### 3.7.6 Speaker Check

1. If a speaker was installed, select SPKR and receive COM audio on the selected COM. When the speaker is selected, the selected Receivers on the GMA (COM, NAV, AUX ) should be heard from the speaker.



#### CAUTION

*Be sure to check all aircraft control movements before flight is attempted to ensure that the wiring harness does not touch any moving part.*

This completes the in-aircraft post installation checkout. Perform a flight test after installing the unit to ensure satisfactory performance of the audio functions.

### 3.7.7 Marker Beacon Operation, GMA 245R MKR only

1. With a marker signal generator/transmitter test set, generate Marker Tones.
2. From the pilot headset position, verify that marker audio can be heard when selected.
3. If the system includes integrated lamp annunciation, verify that each marker tone illuminates the proper lamp.



#### NOTE

*Outer Marker – Blue Lamp – 400 Hz (AM or received audio tone)  
Middle Marker – Amber Lamp – 1300 Hz (AM or received audio tone)  
Inner Marker – White Lamp – 3000 Hz (AM or received audio tone)*



#### NOTE

*For instructions to configure Marker RF threshold sensitivity and audio volume settings, see the Installation Manual for the avionics system to which it is integrated for User Interface control..*

4. Verify that during HI SENS operation, the RF threshold is more sensitive (marker audio/indication occurs as a lower RF power) when in HI SENSE mode.

## 3.8 Continued Airworthiness

Other than for regulatory checks, maintenance of the GMA 245/245R is "on condition" only. Periodic maintenance of the GMA 245/245R is not required. Instructions for Continued Airworthiness (ICA) are not required for this product under 14 CFR Part 21 since the GMA 245/245R has received no FAA approval or endorsement.



### 3.9 Diagnostics Information

The GMA 245 is capable of displaying diagnostics information while in normal mode of operation. To show the diagnostics information press the PLAY key for five seconds. While still holding the PLAY key, all key annunciators will turn off except for those associated with certain diagnostic states. All key annunciators are off if no diagnostic information is available. The image below depicts which key annunciators are associated with which diagnostic states.

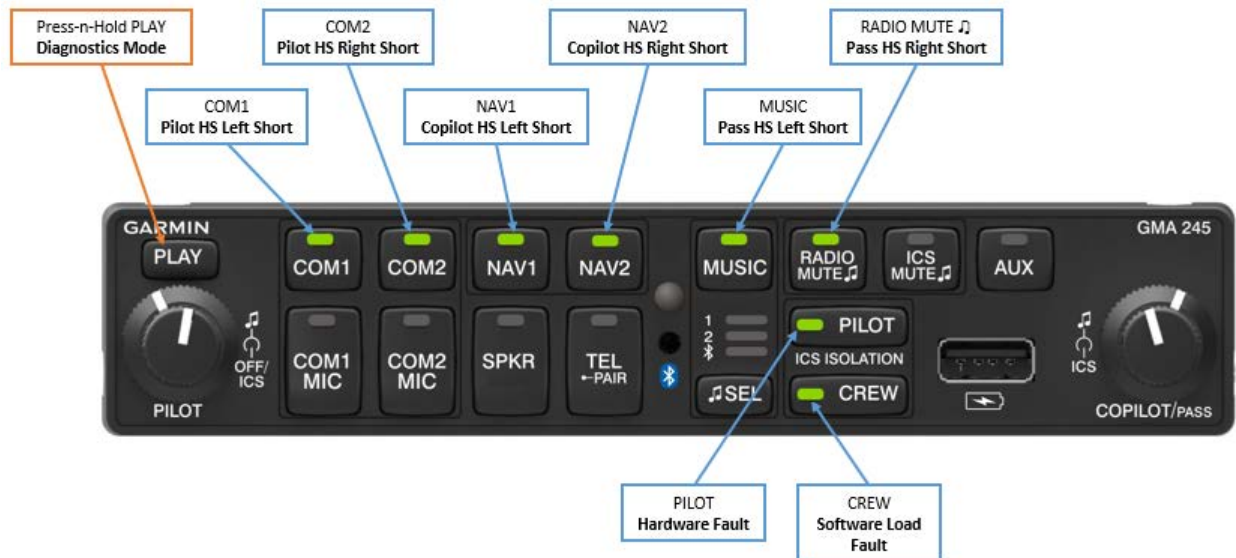

**Figure 3-14 Diagnostics Mode**

- A Headset Short indication means that the unit has detected the associated headset wire is shorted to ground or to another headset channel. No headset short should be detected if the headset jack is wired for a stereo jack, and the headset is a stereo headset. A headset short may be detected for a mono headset.
- A Hardware Fault indication means the unit has detected an internal unrecoverable fault. Contact Garmin Aviation Customer support for assistance.
- A Software Load Fault indication means the previous software update didn't complete successfully. Retry loading software from the loader card to resolve this fault.

### 3.10 Disabling Bluetooth

To aid in troubleshooting the GMA 245, Bluetooth function can be disabled. To disable Bluetooth:

1. Press and hold the TEL key for 5 seconds.
2. An audio clip will be heard in the headset that says "Bluetooth Disabled".
3. To re-enable Bluetooth without power cycling, press and hold the TEL key for 5 seconds.
4. An audio clip will be heard in the headset that says "Bluetooth Enabled".



#### NOTE

Once disabled, the GMA 245 Bluetooth function does not remain disabled after powercycling. The GMA 245 Bluetooth function is always enabled following a power cycle.

## 4 SYSTEM INTERCONNECTS

### 4.1 Connector Description

The GMA 245 has two 44-pin connectors located at the rear of the unit designated J2401 and J2402 which are oriented as shown in Figure 4-1. The GMA 245 is installed into a rack with shield block backshells. The GMA 245R is remote mounted using jackscrew backshells.

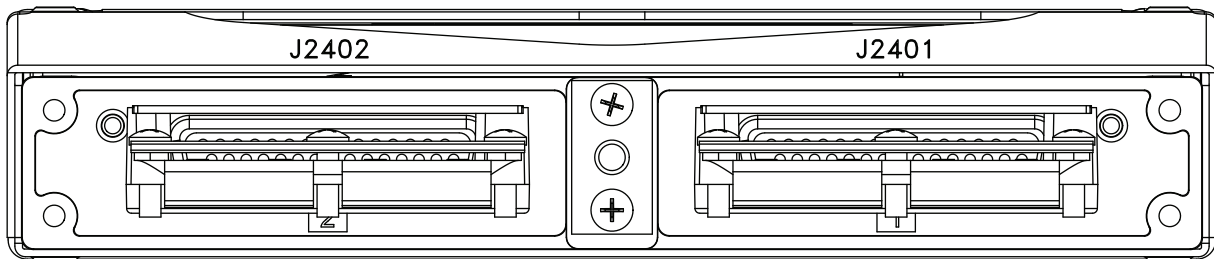

Figure 4-1 Rear View of Backplate and Connectors

### 4.2 Pin List

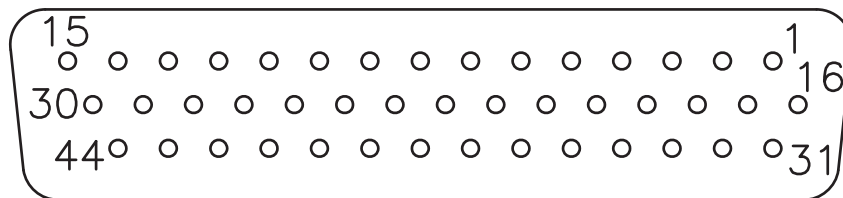

Figure 4-2 Rear Connectors J2401 & J2402, Viewed from Back of Unit

J2401 and J2402 pins are configured as shown in Figure 4-2. J2401 and J2402 pin assignments are given in Table 4-1, [Table 4-2](#), and [Appendix C](#).

Following the [Table 4-1](#) & [Table 4-2](#), additional tables group pin connections by function.

An asterisk (\*) following a signal name denotes that the signal is active low logic. Active low inputs are connected to ground to activate. Active low outputs sink current to ground when active.

#### 4.2.1 P2401 Connector

Table 4-1 J2401 Pin Assignments

Pin	Pin Name	I/O
1	RESERVED	--
	MARKER ANTENNA HI (GMA 245R MKR only)	IN
2	RESERVED	--
	MARKER ANTENNA LO (GMA 245R MKR only)	--
3	XCVR 3 AUDIO IN (WIRED TEL)	IN
4	XCVR 3 AUDIO LO (WIRED TEL)	--
5	XCVR 3 MIC OUT HI (WIRED TEL)	OUT
6	RESERVED	--
7	RCVR 4 AUDIO IN HI (AUX 2)	IN

**Table 4-1 J2401 Pin Assignments**

Pin	Pin Name	I/O
8	RCVR 4 AUDIO IN LO (AUX 2)	--
9	COM 1 AUDIO IN HI	IN
10	COM 1 AUDIO LO	--
11	COM 1 MIC AUDIO OUT HI	OUT
12	COM 1 MIC KEY* OUT	OUT
13	COM 2 AUDIO IN HI	IN
14	COM 2 AUDIO LO	--
15	COM 2 MIC AUDIO OUT HI	OUT
16	PILOT ICS KEY*	IN
17	NAV 1 AUDIO IN HI	IN
18	NAV 1 AUDIO IN LO	--
19	NAV 2 AUDIO IN HI	IN
20	NAV 2 AUDIO IN LO	--
21	RCVR 3 AUDIO IN HI (AUX 1)	IN
22	RCVR 3 AUDIO IN LO (AUX 1)	--
23	RCVR 5 AUDIO IN HI (AUX 3)	IN
24	COM ACTIVE OUT*	OUT
25	RESERVED	--
26	RESERVED	--
27	RESERVED	--
28	RESERVED	--
29	ALERT 3 AUDIO IN HI	IN
30	COM 2 MIC KEY* OUT	OUT
31	ALERT 1 AUDIO IN HI	IN
32	ALERT 1 AUDIO IN LO	--
33	PILOT MIC AUDIO IN HI	IN
34	PILOT MIC KEY* IN	IN
35	PILOT MIC AUDIO IN LO	--
36	CAN BUS HI	I/O
37	CAN BUS LO	I/O
38	RESERVED	--
39	RESERVED	--
40	PASS HEADSET AUDIO OUT LEFT	OUT
41	PASS HEADSET AUDIO OUT RIGHT	OUT
42	PASS HEADSET AUDIO OUT LO	--
43	ALERT 3, 4, AUX 3 AUDIO IN LO	--
44	ALERT 4 AUDIO IN HI	IN

\*Denotes Active Low (Inputs: ground to activate; Outputs: grounded when active)

## 4.2.2 J2402 Connector

**Table 4-2 J2402 Pin Assignments**

Pin	Pin Name	I/O
1	PILOT HEADSET AUDIO OUT LO	--
2	COPILOT HEADSET AUDIO OUT LO	--
3	COPILOT HEADSET AUDIO OUT LEFT	OUT
4	COPILOT HEADSET AUDIO OUT RIGHT	OUT
5	LIGHTING BUS 14V LO/28V LO	--
6	LIGHTING BUS 14V HI/28V LO	IN
7	LIGHTING BUS 14V HI/28V HI	IN
8	AIRCRAFT POWER	IN
9	AIRCRAFT POWER	IN
10	POWER GROUND	--
11	POWER GROUND	--
12	RESERVED	--
13	PASSENGER ICS KEY*	IN
14	ALERT 2 LO, FAILSAFE AUDIO IN LO	--
15	ALERT 2 AUDIO IN HI	IN
16	PILOT HEADSET AUDIO OUT LEFT	OUT
17	RESERVED	--
18	RESERVED	--
19	RESERVED	--
20	COM SWAP*	IN
21	GROUND	--
22	PLAY KEY*	IN
23	MUSIC 1 IN LEFT	IN
24	MUSIC 1 IN RIGHT	IN
25	MUSIC 1 IN LO	--
26	MUSIC 2 IN LEFT	IN
27	MUSIC 2 IN RIGHT	IN
28	MUSIC 2 IN LO	--
29	FAILSAFE WARN AUDIO IN HI	IN
30	COPILOT ICS KEY*	IN
31	PILOT HEADSET AUDIO OUT RIGHT	OUT
32	COPILOT MIC AUDIO IN HI	IN
33	COPILOT MIC KEY* IN	IN
34	COPILOT MIC AUDIO IN LO	--
35	PASS 1 MIC AUDIO IN HI	IN

\*Denotes Active Low (Inputs: ground to activate; Outputs: grounded when active)

**Table 4-2 J2402 Pin Assignments**

Pin	Pin Name	I/O
36	PASS 1 MIC AUDIO IN LO	--
37	PASS 2 MIC AUDIO IN HI	IN
38	PASS 2 MIC AUDIO IN LO	--
39	PASS 3 MIC AUDIO IN HI	IN
40	PASS 3 MIC AUDIO IN LO	--
41	PASS 4 MIC AUDIO IN HI	IN
42	PASS 4 MIC AUDIO IN LO	--
43	SPEAKER AUDIO OUT LO	--
44	SPEAKER AUDIO OUT HI	OUT

\* Denotes Active Low (Inputs: ground to activate; Outputs: grounded when active)

### 4.3 Aircraft Power

The GMA 245 has four pins for aircraft power bus inputs. Use one wire for each of the pins connecting to the aircraft power and ground. Do not splice the power and ground pins at the unit and use only one wire to aircraft power and ground.

**Table 4-3 Aircraft Power**

Pin	Connector	Pin Name	I/O
8	J2402	AIRCRAFT POWER	IN
9	J2402	AIRCRAFT POWER	IN
10	J2402	POWER GROUND	--
11	J2402	POWER GROUND	--

### 4.4 CAN Bus

The CAN bus is used to interface with G3X Touch systems, and conforms to the BOSCH standard for Controller Area Network 2.0-B, and complies with ISO 11898.

**Table 4-4 CAN Bus**

Pin	Connector	Pin Name	I/O
36	J2401	CAN BUS HI	I/O
37	J2401	CAN BUS LO	I/O

#### 4.4.1 CAN Bus Terminator

The following procedures are applicable **only if the GMA 245 is at the end of the CAN bus**, a 120  $\Omega$  termination will be required to be added between the CAN HI and CAN LO pins at the unit. This termination can be accomplished in 2 different ways.

##### Method 1

Using a 1/4 Watt 120  $\Omega$  5% wirewound resistor, splice in the resistor at the unit pins connecting one side of the resistor to HI and the other to the LO. Heat shrink over the leads of the resistor to prevent shorting to the backshell.

##### Method 2

Use the optional accessory GPN 011-03002-00 (Connector Kit, 9 Pin, w/CAN Term). Referencing the J2401 wiring diagrams in this manual, install 011-03002-00 no more than 0.3 meters from the GMA. Pins 1 and 2 are the resistor connection for the 9 pin D-sub terminator in this kit. This kit allows easy removal of the termination for allowing CAN Bus changes in the aircraft installation.

#### 4.5 Lighting Bus

The GMA 245 can be configured to track a 14 or 28 Vdc lighting bus using these inputs. Refer to [Appendix C](#) for lighting interconnections.

Backlighting refers only to the lighting of the text labels on the front panel and is controlled by the inputs in Table 4-5. The brightness of the LED annunciators that illuminate each key when selected is controlled by a photocell that operates independently of the backlight input.



#### NOTE

*Backlighting of key and panel text is controlled by the aircraft lighting bus inputs if the lighting bus is connected. If the lighting bus is not connected, all backlighting is controlled by the photocell.*

**Table 4-5 Lighting Bus**

Pin	Connector	Pin Name	I/O
5	J2402	LIGHTING BUS 14V LO/28V LO	--
6	J2402	LIGHTING BUS 14V HI/28V LO	IN
7	J2402	LIGHTING BUS 14V HI/28V HI	IN

## 4.6 Audio Inputs/Outputs and Mic Keys

### 4.6.1 Mic Audio Inputs and Mic Keys

**Table 4-6 Mic Audio Inputs and Mic Keys**

Pin	Connector	Pin Name	Description	I/O
34	J2401	PILOT MIC KEY* IN	Enables respective MIC audio into the selected transceiver unit	IN
33	J2402	COPILOT MIC KEY* IN		IN
33	J2401	PILOT MIC AUDIO IN HI	Pilot Mic audio input and ground reference	IN
35	J2401	PILOT MIC AUDIO IN LO		--
32	J2402	COPILOT MIC AUDIO IN HI	Copilot Mic audio input and ground reference	IN
34	J2402	COPILOT MIC AUDIO IN LO		--
35	J2402	PASS 1 MIC AUDIO IN HI	Passenger 1 Mic audio and ground reference	IN
36	J2402	PASS 1 MIC AUDIO IN LO		--
37	J2402	PASS 2 MIC AUDIO IN HI	Passenger 2 Mic audio and ground reference	IN
38	J2402	PASS 2 MIC AUDIO IN LO		--
39	J2402	PASS 3 MIC AUDIO IN HI	Passenger 3 Mic audio and ground reference	IN
40	J2402	PASS 3 MIC AUDIO IN LO		--
41	J2402	PASS 4 MIC AUDIO IN HI	Passenger 4 Mic audio and ground reference	IN
42	J2402	PASS 4 MIC AUDIO IN LO		--

\*Denotes Active Low (Ground to activate)

### 4.6.2 COM Audio and Mic Keys

**Table 4-7 COM Audio and Mic Keys**

Pin	Connector	Pin Name	Description	I/O
12	J2401	COM 1 MIC KEY* OUT	Enables transmission on the respective transceiver unit	OUT
30	J2401	COM 2 MIC KEY* OUT		OUT
9	J2401	COM 1 AUDIO IN HI	COM 1 Audio Input	IN
11	J2401	COM 1 MIC AUDIO OUT HI	COM 1 Audio Output	OUT
10	J2401	COM 1 AUDIO LO	Ground Reference for COM 1	--
13	J2401	COM 2 AUDIO IN HI	COM 2 Audio Input	IN
15	J2401	COM 2 MIC AUDIO OUT HI	COM 2 Audio Output	OUT
14	J2401	COM 2 AUDIO LO	Ground Reference for COM 2	--

\*Denotes Active Low (grounded when active)

### 4.6.3 Alert Audio I/O

**Table 4-8 Alert Audio I/O**

Pin	Connector	Pin Name	Description	I/O
31	J2401	ALERT 1 AUDIO IN HI	Alert 1 Audio Input	IN
32	J2401	ALERT 1 AUDIO IN LO	Ground Reference for Alert 1	--
15	J2402	ALERT 2 AUDIO IN HI	Alert 2 Audio Input	IN
14	J2402	ALERT 2 LO, FAILSAFE AUDIO IN LO	Ground Reference for Alert 2	
29	J2401	ALERT 3 AUDIO IN HI	Alert 3 Audio Input	IN
43	J2401	ALERT 3, 4 AUX 3 AUDIO IN LO	Ground Reference for Alert 3 & 4	--
44	J2401	ALERT 4 AUDIO IN HI	Alert 4 Audio Input	IN

### 4.6.4 RCVR, AUX, and NAV Audio Inputs

**Table 4-9 AUX and NAV Audio Inputs**

Pin	Connector	Pin Name	Description	I/O
21	J2401	RCVR 3 AUDIO IN HI (AUX 1)	RCVR 3/AUX 1 Audio Input	IN
22	J2401	RCVR 3 AUDIO IN LO (AUX 1)	Ground Reference for RCVR 3/AUX 1 Input	--
7	J2401	RCVR 4 AUDIO IN HI (AUX 2)	RCVR 4/AUX 2 Audio Input	IN
8	J2401	RCVR 4 AUDIO IN LO (AUX 2)	Ground Reference for RCVR 4/AUX 2 Input	--
23	J2401	RCVR 5 AUDIO IN HI (AUX 3)	RCVR 5/AUX 3 Audio Input	IN
43	J2401	ALERT 3, 4 AUX 3 AUDIO IN LO	Ground Reference for RCVR 5/AUX 3 Audio Input	--
17	J2401	NAV 1 AUDIO IN HI	NAV 1 Audio Input	IN
18	J2401	NAV 1 AUDIO IN LO	NAV 1 Ground Reference	--
19	J2401	NAV 2 AUDIO IN HI	NAV 2 Audio Input	IN
20	J2401	NAV 2 AUDIO IN LO	NAV 2 Ground Reference	--



#### 4.6.5 Failsafe Warning Audio

Failsafe audio is audio from another device that is heard when the GMA is in failsafe mode (power off or unit failure) and is desired to be heard in addition to the COM audio.

**Table 4-10 Failsafe Warning Audio**

Pin	Connector	Pin Name	Description	I/O
29	J2402	FAILSAFE WARN AUDIO IN HI	In the event of power loss, if wired, failsafe warning audio will be heard in the Pilot's Left headset in addition to the COM1 Audio Input.	IN
14	J2402	ALERT 2 LO, FAILSAFE AUDIO IN LO	Ground Reference for Failsafe Warning Audio Input	--



#### **CAUTION**

*During failsafe mode both FAILSAFE WARN AUDIO IN HI and COM 1 AUDIO INPUT are connected to the PILOT HEADSET LEFT OUTPUT. When in failsafe the output of the COM 1 radio and the output of the device connected to FAILSAFE WARN AUDIO IN HI will become shorted together, potentially causing damage or interference. If the FAILSAFE WARN AUDIO IN HI is used, it may be necessary to install summing resistors in series between these sources and the inputs to the audio panel to protect the outputs from damage.*

#### 4.6.6 Music Inputs

The MUSIC LO signals are not the same reference as other ground connections. The MUSIC LO signals should be used as part of a differential pair (along with the MUSIC RIGHT and MUSIC LEFT signals). If the MUSIC LO signal is tied to a ground connection, the music will contain noise, and the audio quality will be degraded.

**Table 4-11 Music Inputs**

Pin	Connector	Pin Name	Description	I/O
23	J2402	MUSIC 1 IN LEFT	Music 1 Input	IN
24	J2402	MUSIC 1 IN RIGHT		
25	J2402	MUSIC 1 IN LO	Differential Reference for Music 1	--
26	J2402	MUSIC 2 IN LEFT	Music 2 Input	IN
27	J2402	MUSIC 2 IN RIGHT		
28	J2402	MUSIC 2 IN LO	Differential Reference for Music 2	--

#### 4.6.7 Tel Audio I/O

**Table 4-12 TEL Audio/XCVR 3 I/O**

Pin	Connector	Pin Name	Description	I/O
3	J2401	XCVR 3 AUDIO IN (WIRED TEL)	Telephone Audio Input	IN
4	J2401	XCVR 3 AUDIO LO (WIRED TEL)	Ground Reference for Telephone	--
5	J2401	XCVR 3 MIC OUT HI (WIRED TEL)	TEL MIC Audio Output	OUT

#### 4.6.8 Headset Outputs

Garmin recommends that stereo headsets and stereo jacks be used to fully utilize the 3D audio features of the GMA 245. A true mono headset will work correctly with the GMA 245, but only mono (left channel) audio will be heard, and 3D audio will not be available (even if enabled). The GMA 245 will detect the mono headset (if stereo jacks are used), and automatically switch to mono operation. 3D audio is not available with mono headsets or in installations that use mono jacks for the headsets.

In aircraft systems that are wired with stereo headset jacks, if a true mono headset is plugged into the jack, the right audio channel is shorted to ground. In this condition the GMA 245 will detect the right channel short, and turn off the right channel audio to the headset output to protect the GMA 245 headset output from driving a signal into a short (and also for internal audio routing determined by the mono headset plugged into the headset jack).

In aircraft systems that use mono headset jacks, and are wired correctly (if used, mono jacks should always use left channel audio and headset lo), 3D audio will not be available, and only left channel audio for music inputs or headset outputs will be heard.

**Table 4-13 Headset Outputs**

Pin	Connector	Pin Name	Description	I/O
16	J2402	PILOT HEADSET AUDIO OUT LEFT	Pilot Headset Audio Output	OUT
31	J2402	PILOT HEADSET AUDIO OUT RIGHT		OUT
1	J2402	PILOT HEADSET AUDIO OUT LO		--
3	J2402	COPILOT HEADSET AUDIO OUT LEFT	Copilot Headset Audio Output	OUT
4	J2402	COPILOT HEADSET AUDIO OUT RIGHT		OUT
2	J2402	COPILOT HEADSET AUDIO OUT LO		--

**Table 4-13 Headset Outputs**

Pin	Connector	Pin Name	Description	I/O
40	J2401	PASS HEADSET AUDIO OUT LEFT	Passenger Headset Audio Output	OUT
41	J2401	PASS HEADSET AUDIO OUT RIGHT		OUT
42	J2401	PASS HEADSET AUDIO OUT LO		--

#### 4.6.9 Speaker Audio Out

Do not connect the LO of the speaker to the aircraft chassis. Two wires must be connected from the GMA to the Speaker for the HI and LO signals. If speaker LO is connected to the aircraft chassis ground, the speaker will contain more noise than if connected back to the GMA source connections.

**Table 4-14 Speaker Audio Output**

Pin	Connector	Pin Name	Description	I/O
43	J2402	SPEAKER AUDIO OUT LO	Speaker Audio Output Ground Reference	--
44	J2402	SPEAKER AUDIO OUT HI	Speaker Audio Output Hi	OUT

#### 4.7 Discrete Inputs

The ICS KEYs are enabled by setting switch 1 of the DIP switch to ON. The COM Swap and Play key are always enabled.

**Table 4-15 Discrete Inputs**

Pin	Connector	Pin Name	Description	I/O
16	J2401	PILOT ICS KEY*	Discrete Input	IN
13	J2402	PASSENGER ICS KEY*	Discrete Input	IN
20	J2402	COM SWAP*	Discrete Input	IN
22	J2402	PLAY KEY*	Discrete Input	IN
30	J2402	COPILOT ICS KEY*	Discrete Input	IN

\*Denotes Active Low (Inputs: ground to activate)

#### 4.7.1 Discrete Outputs

**Table 4-16 Discrete Outputs**

Pin	Connector	Pin Name	Description	I/O
24	J2401	COM ACTIVE OUT*	Discrete Out	OUT

\*Denotes Active Low (Grounded when active)

## 4.8 Marker Beacon Antenna, GMA 245R MKR Unit Only

**Table 4-17 Marker Beacon Antenna Pins**

<b>Pin</b>	<b>Connector</b>	<b>Pin Name</b>	<b>Description</b>	<b>I/O</b>
1	J2401	MARKER ANTENNA HI	Antenna Input	IN
2	J2401	MARKER ANTENNA LO	Antenna Ground	--

## APPENDIX:A INSTALLATION CONSIDERATIONS FOR UPGRADING FROM A GARMIN GMA 240



### NOTE

*This appendix contains installation considerations for upgrading from a Garmin GMA 240. This is not a set of comprehensive installation instructions for installing a Garmin GMA 245 in place of a Garmin GMA 240. Read this manual in its entirety before starting any installation.*

### A.1 Mechanical Considerations

- The GMA 240 installation rack is compatible with the GMA 245. Refer to [Section 2.2](#) of this manual for a list of installation materials.
- The GMA 240 connectors are compatible and may be reused.

If replacing a GMA 240 with a GMA 245, the GMA 240 (330-00220-25) connector backshells can be reused. However, grounding the wire shields to the GMA will be easier with the Garmin backshells in GPN 011-02302-00. The Garmin backshells also offer higher immunity to HIRF. Current installations will not be required to change the backshell type, but would benefit from doing so.

### A.2 Electrical Considerations

[Figure A-1](#) shows the GMA 240 pins that may need to be modified to accommodate the GMA 245. Refer to [Section 4](#) and [Appendix C](#) of this manual for a list of pin functions and interconnect examples.

### A.3 GMA 240 to GMA 245 Retrofit Connections

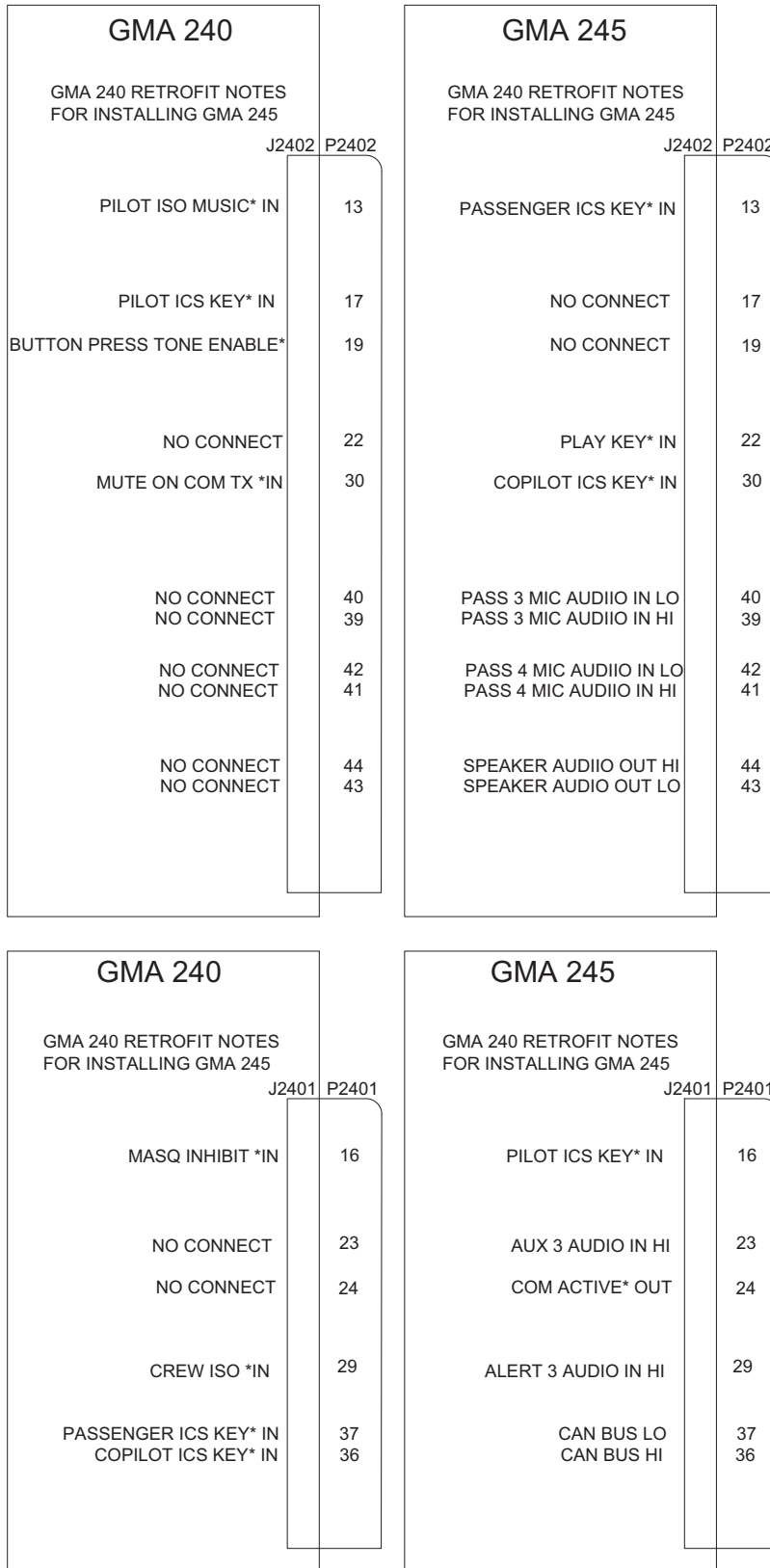

Figure A-1 GMA 240 to GMA 245 Retrofit Connections

APPENDIX B OUTLINE AND INSTALLATION DRAWINGS

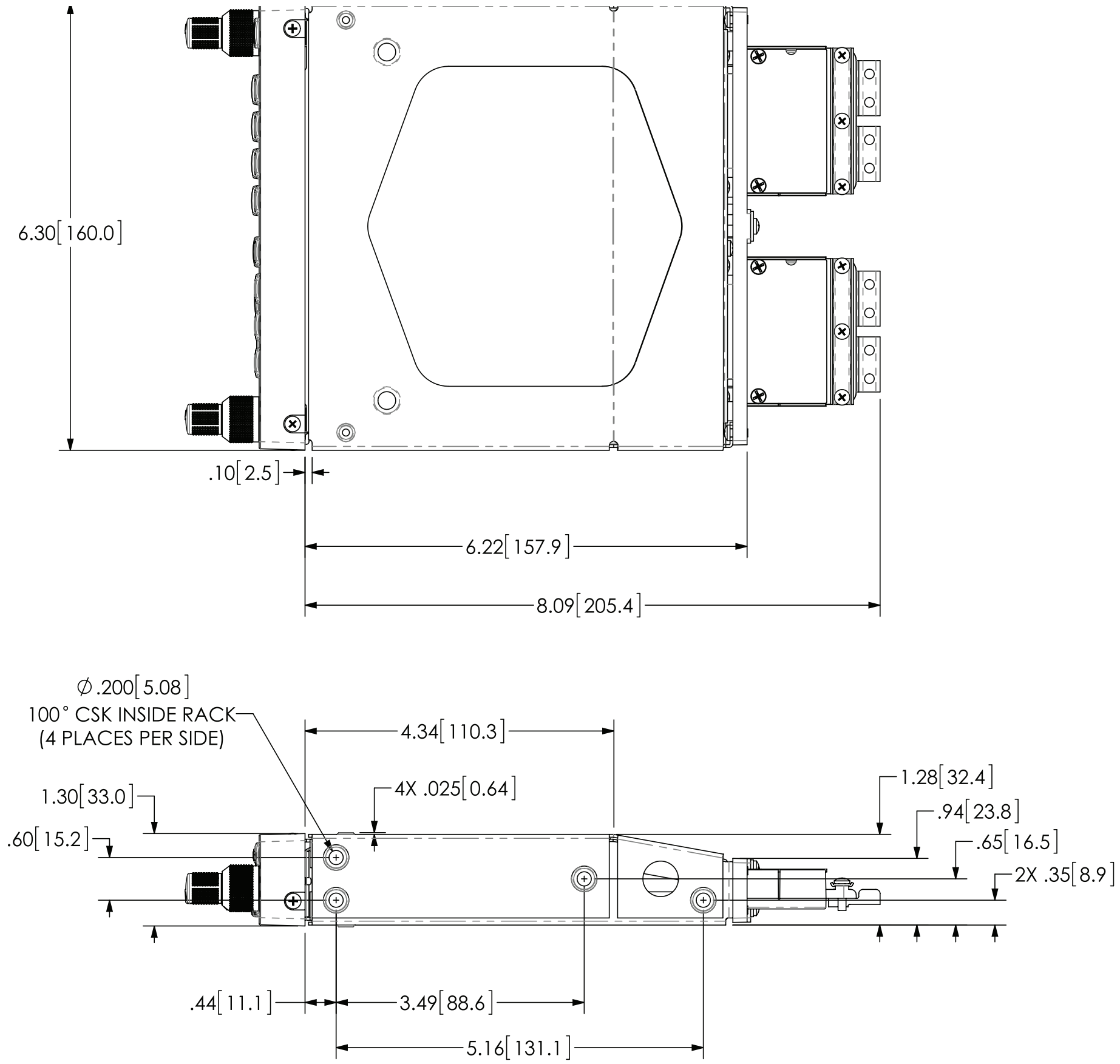

Figure B-1 GMA 245 Outline Drawing

APPENDIX B OUTLINE AND INSTALLATION DRAWINGS

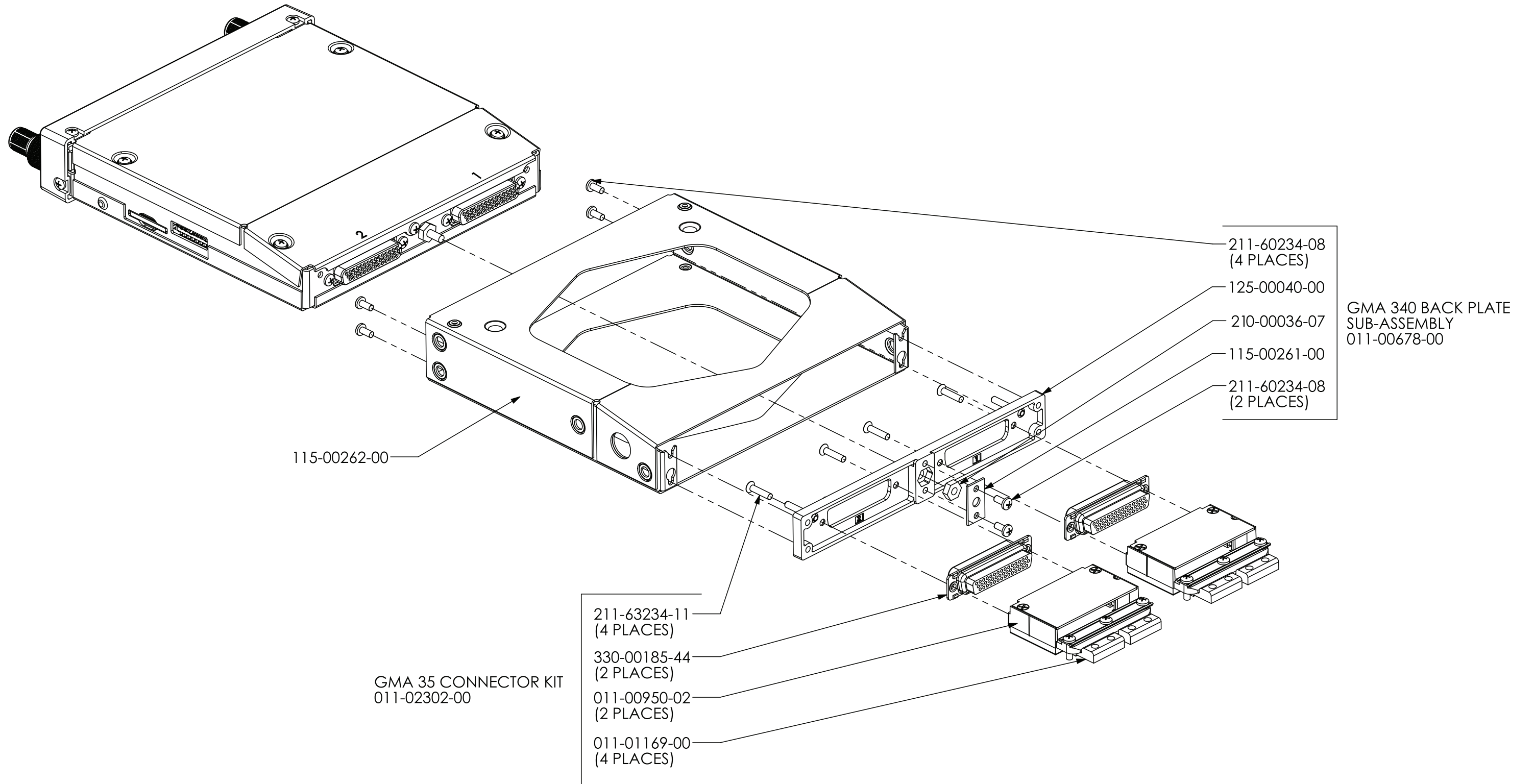

Figure B-2 GMA 245 Installation Drawing





APPENDIX B OUTLINE AND INSTALLATION DRAWINGS

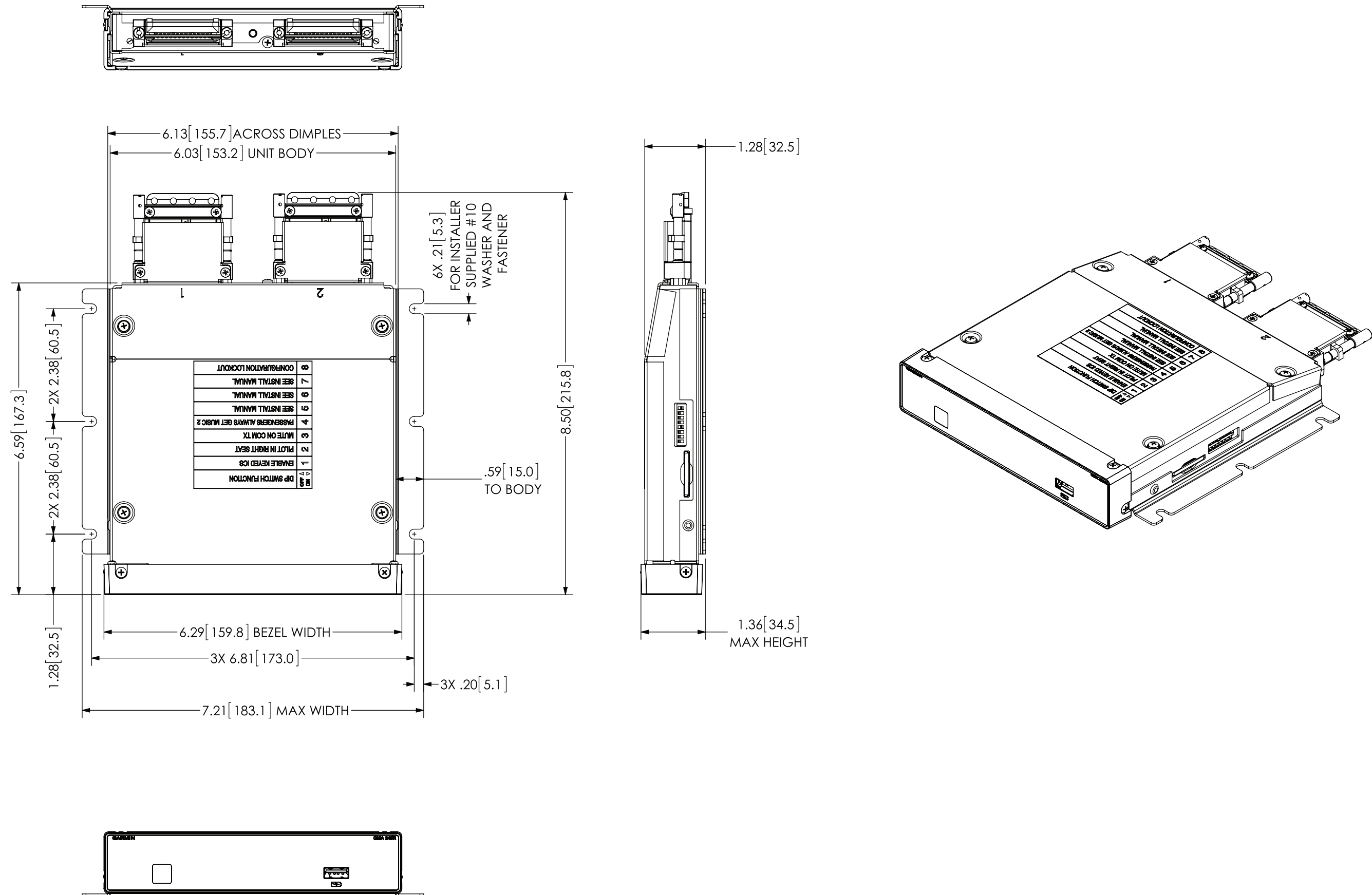
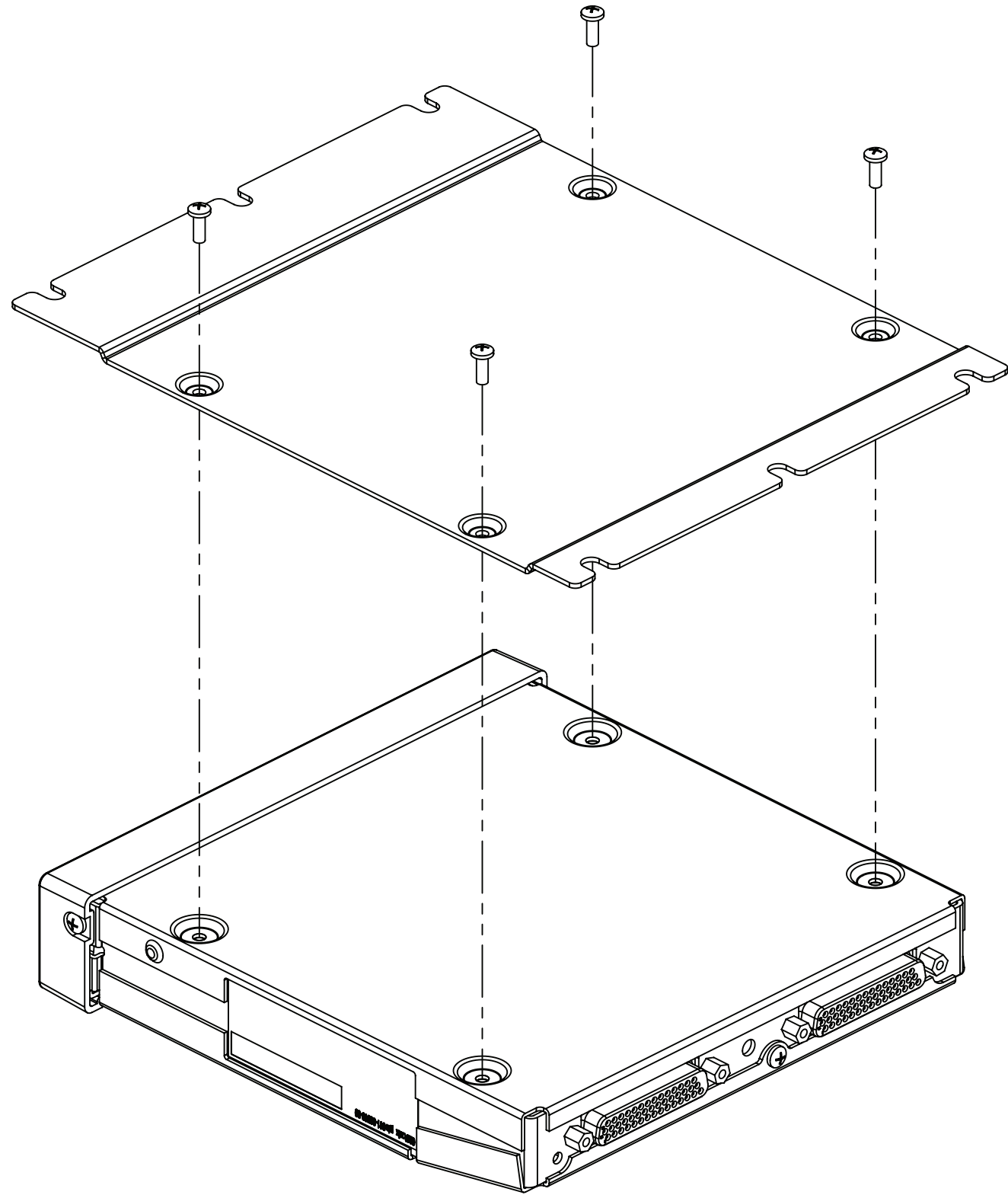
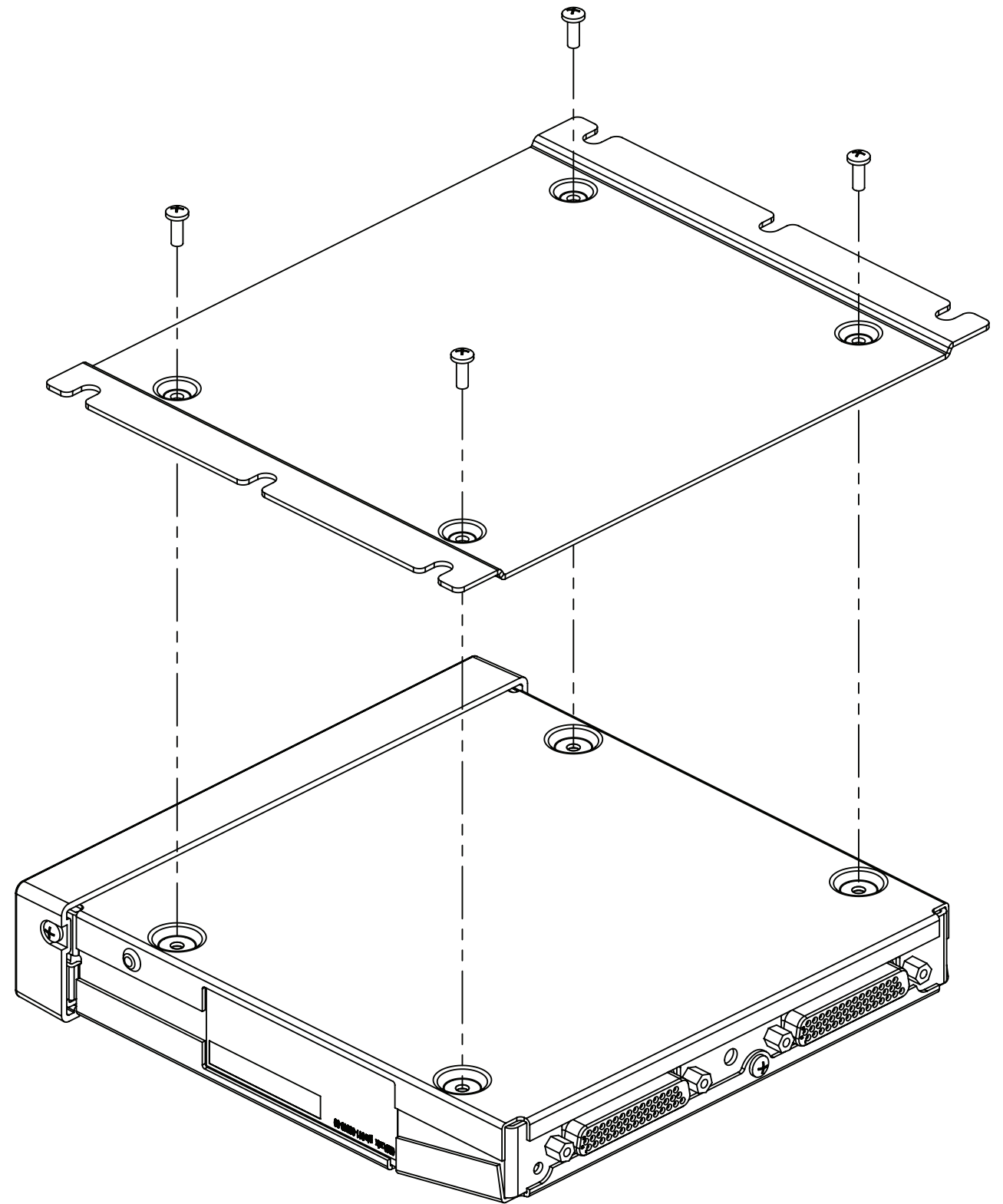

Figure B-4 GMA 245R Outline Drawing, Side Mount Bracket Installation

APPENDIX B OUTLINE AND INSTALLATION DRAWINGS



END MOUNT BRACKET INSTALLATION



SIDE MOUNT BRACKET INSTALLATION

Figure B-5 GMA 245R Installation Drawing, End and Side Bracket Mounting

APPENDIX B OUTLINE AND INSTALLATION DRAWINGS

**OPTION 1:**  
STACK CUTOUT (RACK INSTALLED  
FROM FRONT OF AIRCRAFT PANEL)

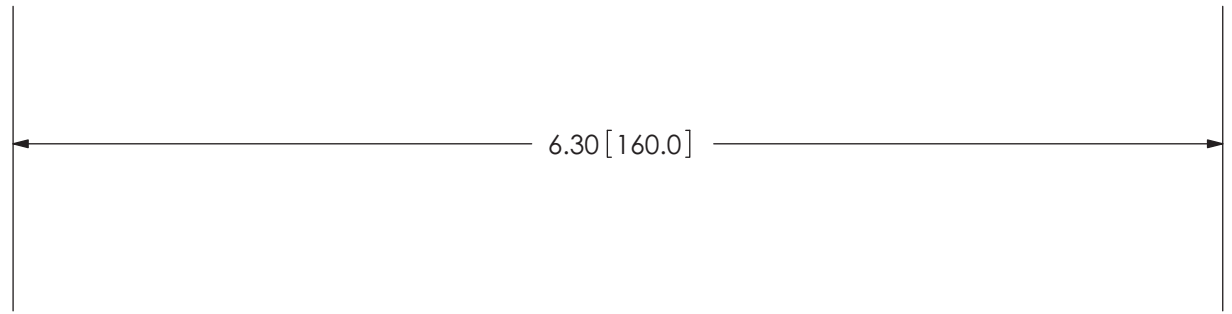

**OPTION 2:**  
RADIO CUTOUT (RACK INSTALLED  
FROM FRONT OF AIRCRAFT PANEL)

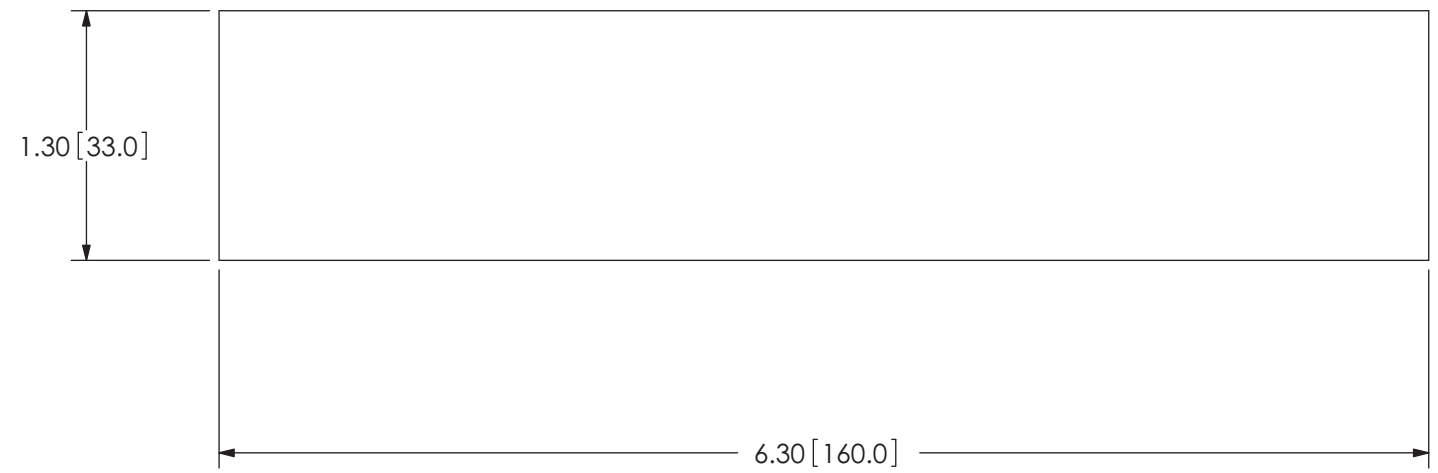

**OPTION 3:**  
RADIO CUTOUT (RACK INSTALLED  
FROM BACK OF AIRCRAFT PANEL  
ONLY) MAXIMUM AIRCRAFT PANEL  
THICKNESS IS .125 INCH [3.2 mm]

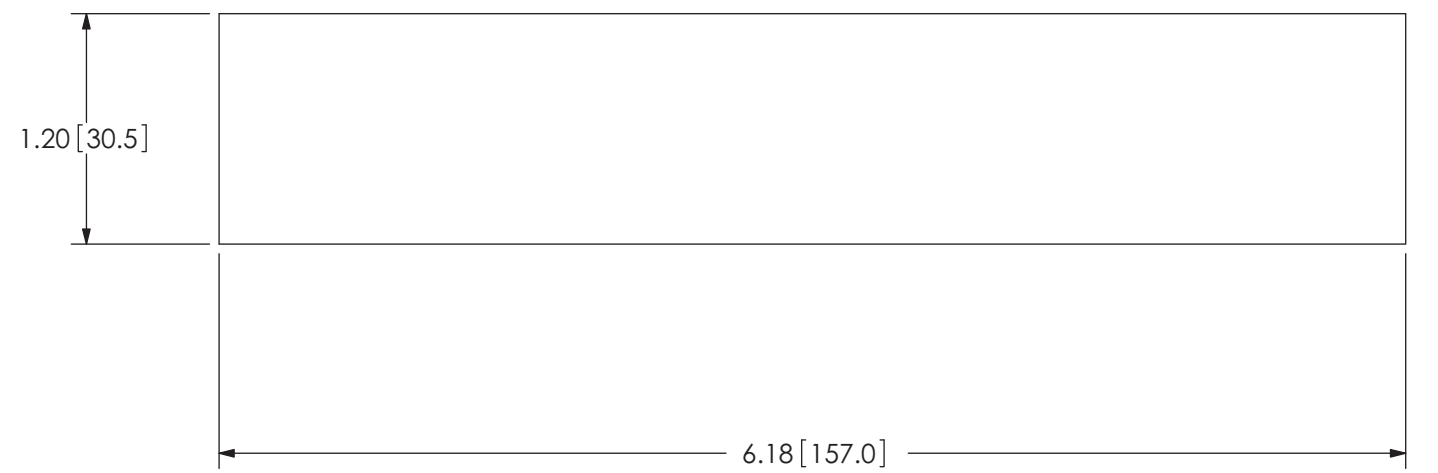

**NOTES:**  
1. DIMENSIONS: INCH [mm]  
2. IF THE FRONT LIP OF THE  
MOUNTING RACK IS BEHIND  
THE SURFACE OF THE AIRCRAFT  
PANEL THE UNIT CONNECTORS  
MAY NOT FULLY ENGAGE.

Figure B-6 GMA 245 Panel Cutout Drawing

APPENDIX C INTERCONNECT DRAWINGS

# GMA 245 INSTALLATION NOTES

1. UNLESS OTHERWISE INDICATED, ALL SHIELDS MUST BE TERMINATED AT THE GMA 245 END ONLY. ALL SHIELDS ARE TIED TO THE BACKSHELL USING RING TERMINALS. FOR GMA 245, USE THE RING TERMINAL ADAPTERS PROVIDED FOR THE BACKSHELLS IN THE CONNECTOR KIT. FOR GMA 245R, CONNECT RING TERMINALS TO THE BACKSHELLS. FOR BOTH UNITS, #8 SCREWS, WASHERS, AND SPLIT WASHERS ARE PROVIDED.
2. UNLESS OTHERWISE NOTED, ALL STRANDED WIRE MUST CONFORM TO MIL-W-22759/16 OR EQUIVALENT. UNLESS OTHERWISE NOTED, ALL SHIELDED WIRE MUST CONFORM TO MIL-C-27500 OR EQUIVALENT.
3. UNLESS OTHERWISE NOTED, ALL WIRES ARE 22 AWG MINIMUM.

4. SYMBOL DESIGNATIONS AND CONNECTOR GUIDANCE:

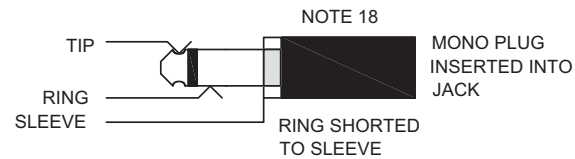
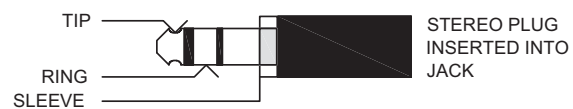
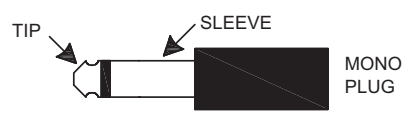
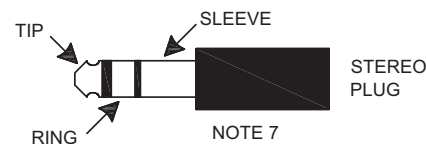
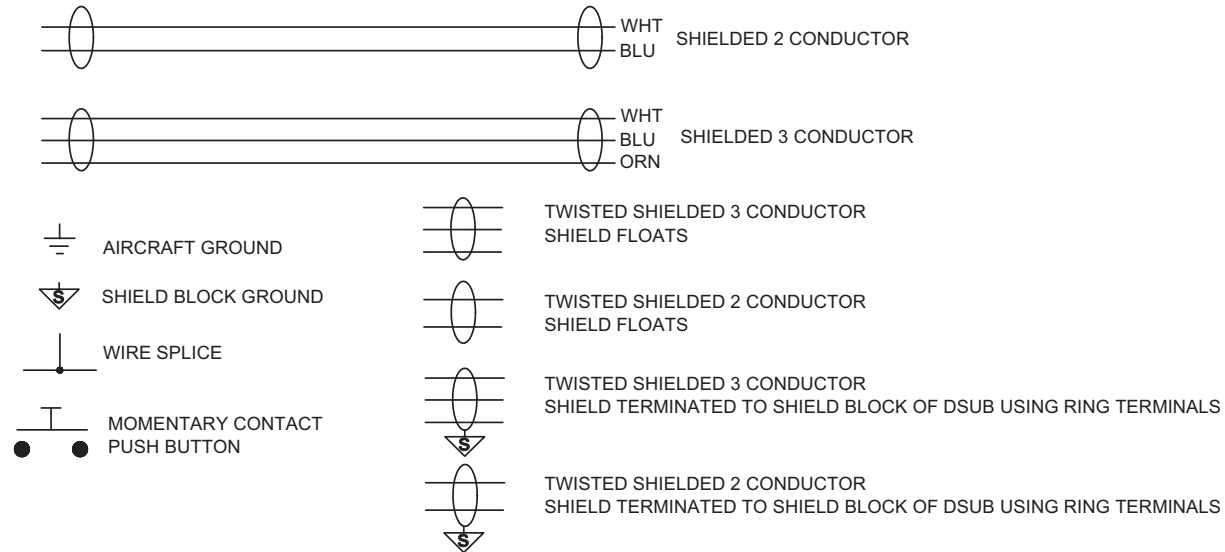

NOTE 5. AUDIO JACK ISOLATION DIAGRAM

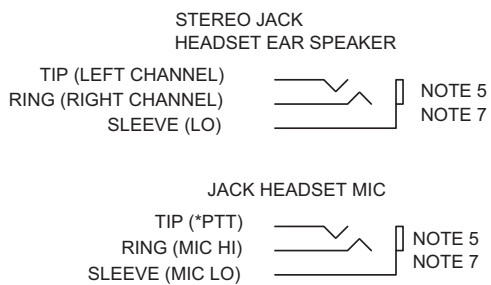
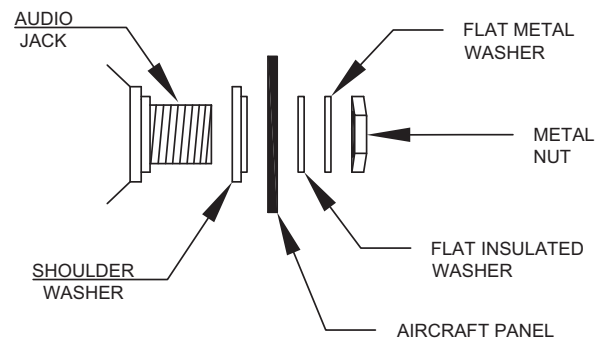

5. ISOLATE JACK SLEEVE (MOUNTING NUT AND NUT PLATE) FROM AIRCRAFT CHASSIS. ALL HEADSET, MICROPHONE, AND MUSIC PHONE JACKS MUST BE ELECTRICALLY ISOLATED FROM GROUND. REFER TO THE FIGURE ABOVE FOR HOW THE JACK IS ISOLATED. NOT ISOLATING WILL CAUSE GROUND LOOPS AND NOISE.
6. THE CONNECTION BETWEEN PTT AND THE MIC JACK TIP IS REQUIRED IF HAND MICS WILL BE USED. \*DENOTES AN ACTIVE LOW SIGNAL.
7. THE HEADSET EAR SPEAKER SLEEVE DIAMETER IS 0.25 INCH AND LARGER THAN THE HEADSET MIC SLEEVE DIAMETER 0.206 INCH.
8. IF THE TRANSCEIVER HAS A SEPARATE RETURN FOR AUDIO IN AND AUDIO OUT, CONNECT BOTH TO THE GMA AUDIO LO AT THE GMA.
9. DO NOT CONNECT THE SPEAKER GROUND RETURN TO THE AIRCRAFT CHASSIS. THE GROUND RETURN MUST GO TO THE GMA.
10. THE LIGHTING BUS VOLTAGE RANGE IS CONFIGURABLE FOR EITHER 14 OR 28 VOLT SYSTEMS. REFER TO INSTALL MANUAL CONFIGURATION OPTIONS.
11. GARMIN RECOMMENDS USING STEREO HEADPHONES. IF MONO JACKS ARE DESIRED, GARMIN RECOMMENDS THE USE OF THE LEFT OUTPUT ONLY (LEAVE THE RIGHT CHANNEL UNCONNECTED). DO NOT CONNECT THE LEFT AND RIGHT CHANNELS TOGETHER.
12. THE TELEPHONE INTERFACE MAY BE WIRED TO A FIXED MOUNTED TELEPHONE SOURCE (SHOWN) OR TO A SUITABLE JACK FOR PORTABLE TELEPHONE.
13. TRANSCEIVER INTERFACES CAN ALSO BE WIRED THROUGH SUITABLE JACKS AND CABLES TO HANDHELD COMS THAT HAVE HEADSET INTERFACE CAPABILITY. THE HANDHELD'S HEADSET OUTPUT (LEFT CHANNEL ONLY IF STEREO) CONNECTS TO THE GMA'S COM AUDIO IN HI AND COM AUDIO LO PINS, THE HANDHELD'S MIC INPUT CONNECTS TO GMA'S COM MIC AUDIO OUT HI AND COM AUDIO LO PINS, AND THE HANDHELD'S PTT KEY CONNECTS TO GMA'S COM MIC KEY\* OUT. SEE TRANSCEIVER'S INSTRUCTION MANUAL.
14. \* DENOTES ACTIVE LOW.
15. MONO ONLY HEADSET JACK CONNECTION DETAIL.
16. USE A MINIMUM 10 WATT SPEAKER. USE 8 OHM SPEAKER FOR 28 VOLT SYSTEMS ONLY. USE 4 OHM SPEAKER FOR 14 OR 28 VOLT SYSTEMS.
17. ICS KEY INPUTS ARE ALSO COMPATIBLE WITH TWO-STAGE PTT KEYS IN WHICH THE FIRST DETENT ACTIVATES THE ICS KEY AND THE SECOND DETENT ACTIVATES THE TRANSCEIVER PTT (CREW ONLY) FOR THAT POSITION.
18. PLUGGING A MONORAIL HEADSET INTO A STEREO JACK SHORTS THE RIGHT CHANNEL OUTPUT TO GROUND. THIS WILL CAUSE EXCESS CURRENT TO BE DRAWN. THIS WILL NOT DAMAGE THE GMA, BUT IS NOT RECOMMENDED. THE GMA WILL DETECT THE SHORTED CHANNEL AND SHUT THE AUDIO TO THE SHORTED CHANNEL OFF TO PREVENT THE INTERNAL AMPLIFIER FROM DRIVING A SIGNAL INTO A SHORT.
19. THE MUSIC LO SIGNALS ARE NOT THE SAME REFERENCE AS OTHER GROUNDS. THE MUSIC LO SIGNALS ARE PART OF A DIFFERENTIAL PAIR WITH THE RIGHT AND LEFT SIGNALS. IF THE MUSIC LO SIGNAL IS TIED TO A GROUND, THE MUSIC WILL CONTAIN NOISE, AND THE AUDIO QUALITY WILL BE DEGRADED.
20. IF THE GMA IS AT THE END OF THE CAN BUS, ADD GPN 011-03002-00 CAN TERMINATION KIT TO THE CAN BUS AS SHOWN. ONLY INSTALL CAN TERMINATION KIT IF THE GMA IS AT THE END OF THE CAN BUS. THE TERMINATION STUB LENGTH SHOULD NOT EXCEED 0.3 METERS. IT IS RECOMMENDED THAT THE GMA BE LOCATED IN THE MIDDLE OF THE CAN BUS SO A TERMINATION KIT IS NOT NEEDED. THE TERMINATION KIT IS AN OPTIONAL ACCESSORY.
21. USE RG400 FOR MARKER BEACON COAXIAL CABLE. THE RF MATING CONNECTION FOR THE ANTENNA (BNC, TNC, N) WILL DEPEND ON THE MARKER BEACON ANTENNA USED. FOR DSUB COAXIAL CABLE INSTALLATION GUIDELINES, REFER TO MARKER INSTALLATION SECTION OF INSTALL MANUAL. AVOID SHARP CORNERS AND ROUTE AWAY FROM HIGH CURRENT WIRING AND ANY TRANSMITTER CABLES.

Figure C-1 Notes for Example Interconnect Drawings

APPENDIX C INTERCONNECT DRAWINGS

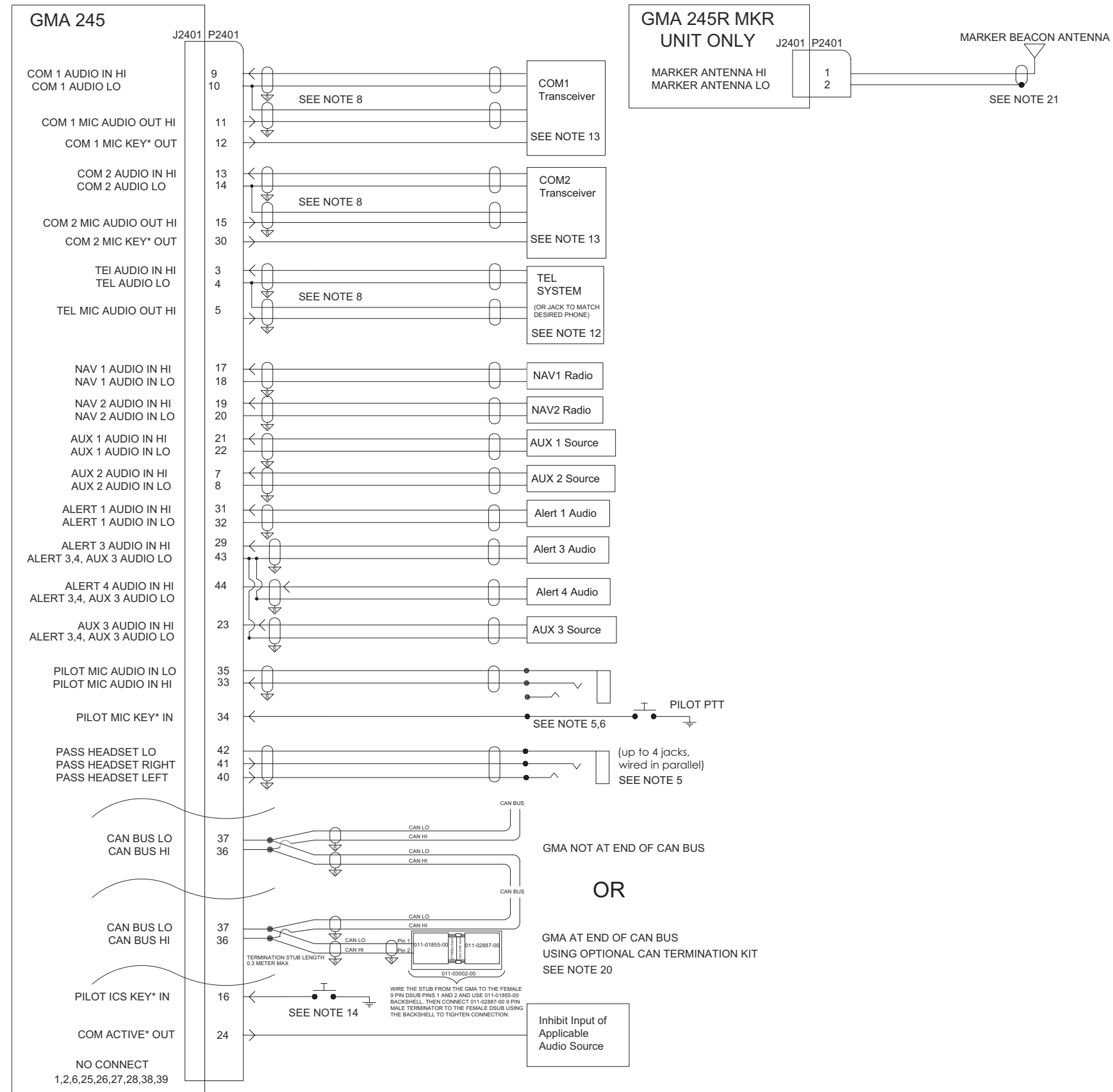

Figure C-2 J2401 Connector Example Interconnect Drawing

APPENDIX C INTERCONNECT DRAWINGS

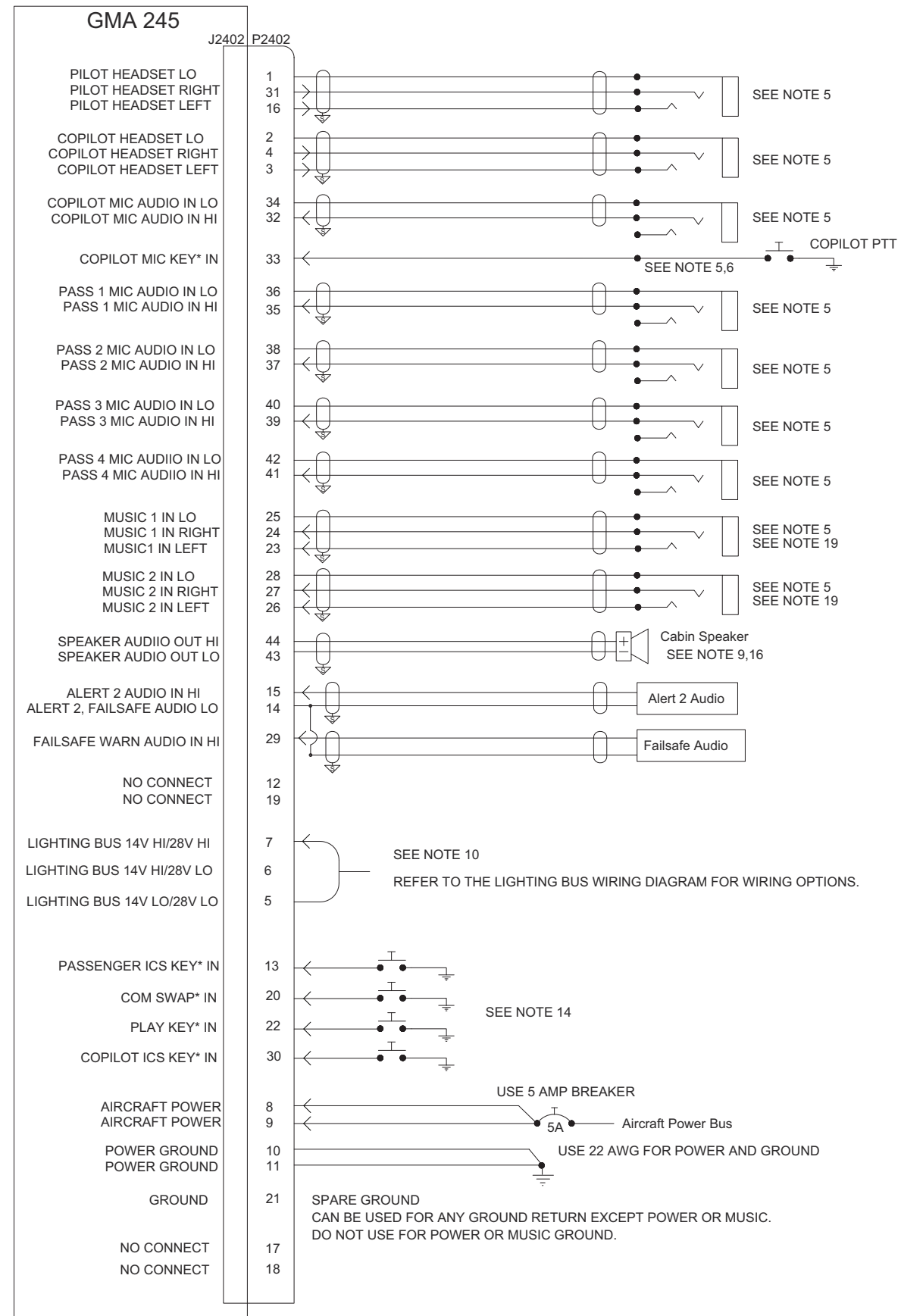
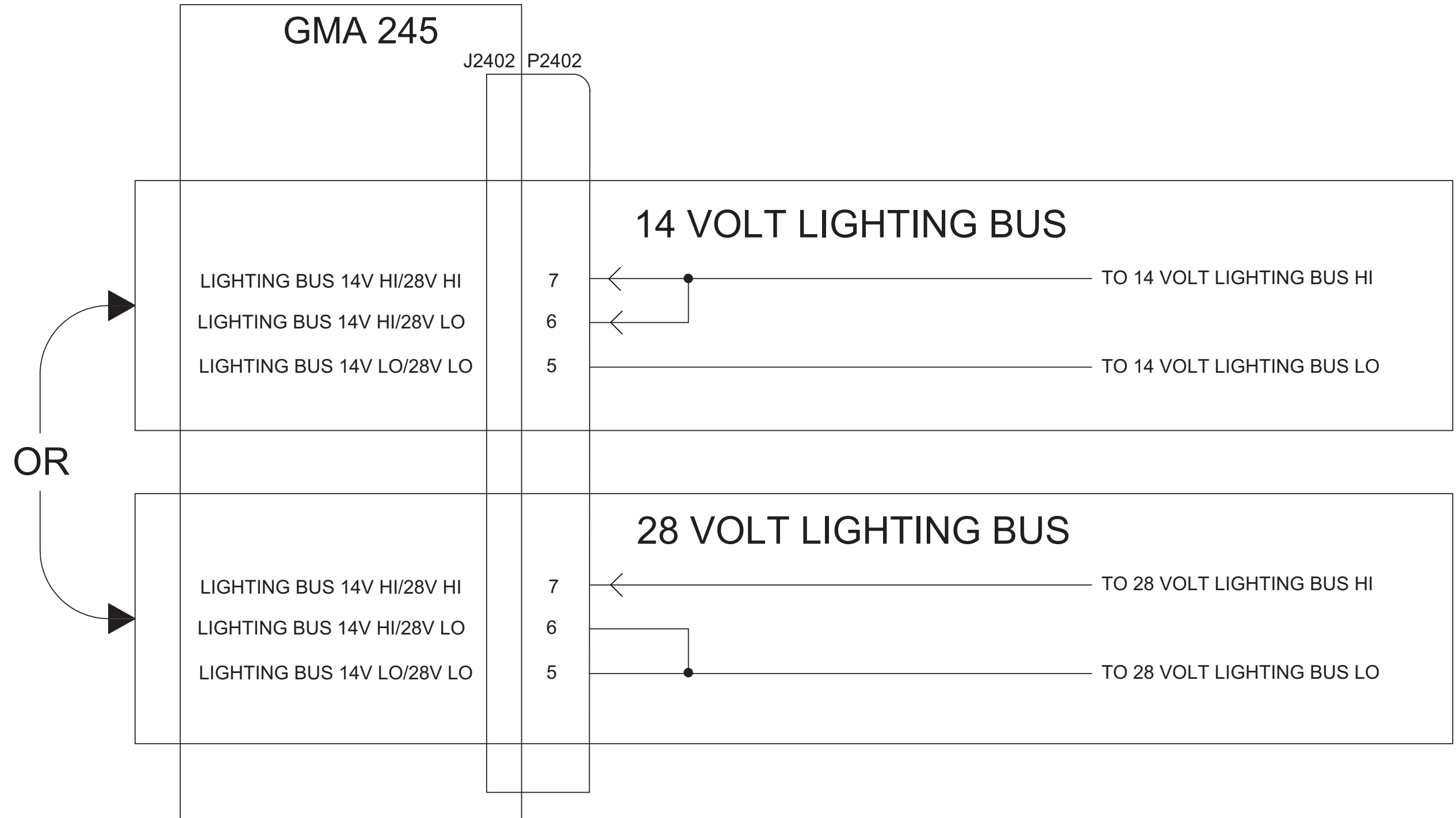

Figure C-3 J2402 Connector Example Interconnect Drawing



IF NEITHER OF THE ABOVE LIGHTING BUS CONFIGURATIONS ARE WIRED, THE UNIT WILL DEFAULT TO USE THE DISPLAY PHOTOCELL FOR LIGHTING CONTROL

Figure C-4 Lighting Bus Example Interconnect Drawing



APPENDIX C INTERCONNECT DRAWINGS

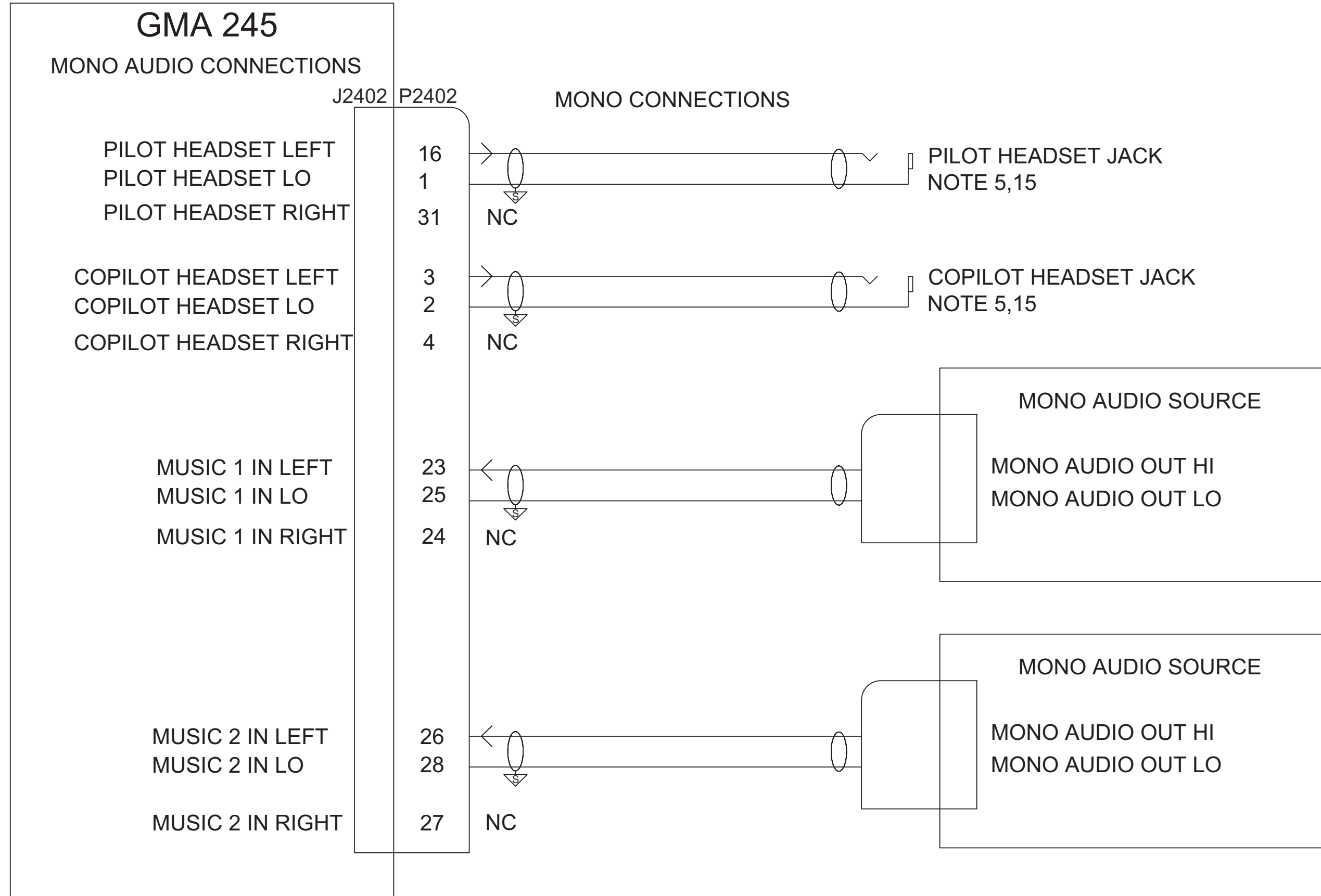

Figure C-5 Mono Audio Example Interconnect Drawing

APPENDIX C INTERCONNECT DRAWINGS

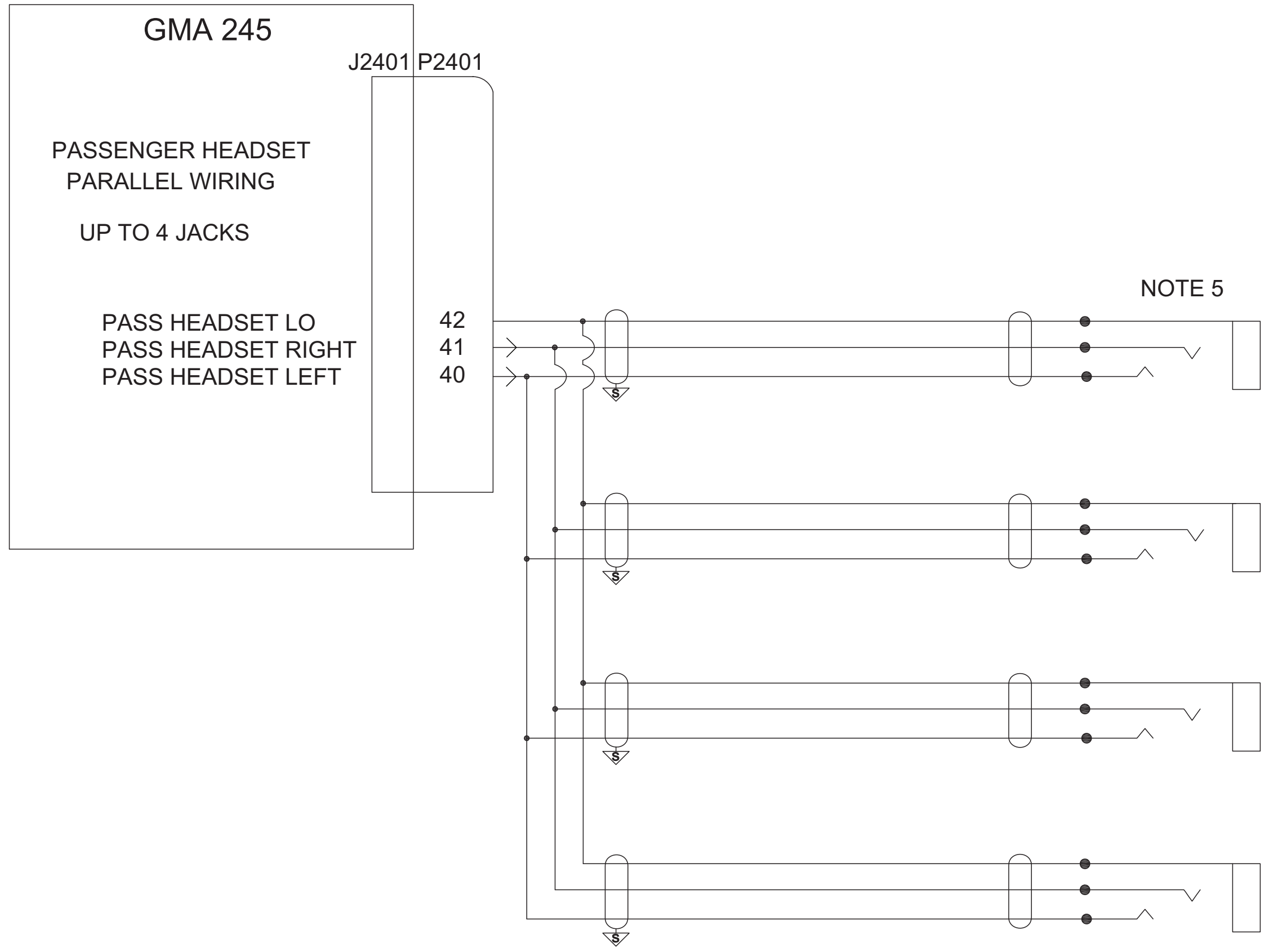

Figure C-6 Four Passenger Headset Wiring Example Interconnect Drawing

APPENDIX C INTERCONNECT DRAWINGS

RECOMMENDED LEMO JACK WIRING WHEN USING PREFABRICATED LEMO HARNESS SUCH AS BOSE PART NUMBER 323172-0010

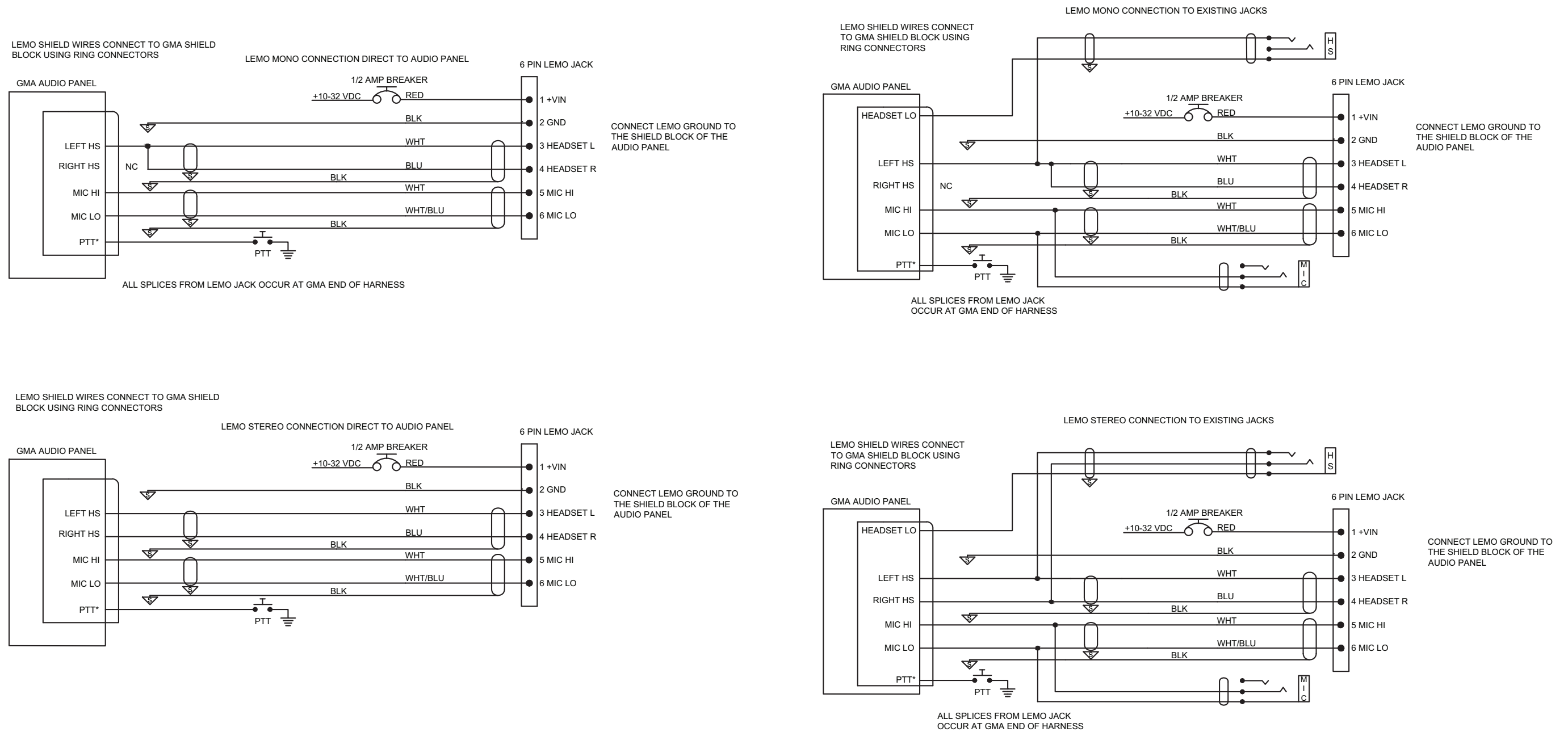

Figure C-7 LEMO Jack Wiring Example Interconnect Drawing

APPENDIX C INTERCONNECT DRAWINGS

GMA 245 J2401

15 COM 2 MIC AUDIO OUT HI	14 COM 2 AUDIO LO	13 COM 2 AUDIO IN HI	12 COM 1 MIC KEY* OUT	11 COM 1 MIC AUDIO OUT HI	10 COM 1 AUDIO LO	9 COM 1 AUDIO IN HI	8 RCVR 4 AUDIO IN LO (AUX 2)	7 RCVR 4 AUDIO IN HI (AUX 2)	6 RESERVED	5 XCVR 3 MIC OUT HI (WIRED TEL)	4 XCVR 3 AUDIO LO (WIRED TEL)	3 XCVR 3 AUDIO IN (WIRED TEL)	2 RESERVED (MARKER ANTENNA LO 245R MKR ONLY)	1 RESERVED (MARKER ANTENNA HI 245R MKR ONLY)
30 COM 2 MIC KEY* OUT	29 ALERT 3 AUDIO IN HI	28 RESERVED	27 RESERVED	26 RESERVED	25 RESERVED	24 DISCRETE C OUT* (COM ACTIVE OUT)	23 RCVR 5 AUDIO IN HI (AUX 3)	22 RCVR 3 AUDIO IN LO (AUX 1)	21 RCVR 3 AUDIO IN HI (AUX 1)	20 NAV 2 AUDIO IN LO	19 NAV 2 AUDIO IN HI	18 NAV 1 AUDIO IN LO	17 NAV 1 AUDIO IN HI	16 DISCRETE 1 INPUT* (PILOT ICS KEY)
44 ALERT 4 AUDIO IN HI	43 ALERT 3, 4, AUX 3 AUDIO IN LO	42 PASS HEADSET AUDIO OUT LO	41 PASS HEADSET AUDIO OUT RIGHT	40 PASS HEADSET AUDIO OUT LEFT	39 RESERVED	38 RESERVED	37 CAN BUS LO	36 CAN BUS HI	35 PILOT MIC AUDIO IN LO	34 PILOT MIC KEY* IN	33 PILOT MIC AUDIO IN HI	32 ALERT 1 AUDIO IN LO	31 ALERT 1 AUDIO IN HI	

GMA 245 J2402

15 ALERT 2 AUDIO IN HI	14 ALERT 2 LO, FAILSAFE AUDIO IN LO	13 PASS ICS KEY	12 RESERVED	11 POWER GROUND	10 POWER GROUND	9 AIRCRAFT POWER	8 AIRCRAFT POWER	7 LIGHTING BUS 14V HI/28V HI	6 LIGHTING BUS 14V HI/28V LO	5 LIGHTING BUS 14V LO/28V LO	4 COPILOT HEADSET AUDIO OUT RIGHT	3 COPILOT HEADSET AUDIO OUT LEFT	2 COPILOT HEADSET AUDIO OUT LO	1 PILOT HEADSET AUDIO OUT LO
30 DISCRETE 6 INPUT* (COPILOT ICS KEY)	29 FAILSAFE WARN AUDIO IN HI	28 MUSIC 2 IN LO	27 MUSIC 2 IN RIGHT	26 MUSIC 2 IN LEFT	25 MUSIC 1 IN LO	24 MUSIC 1 IN RIGHT	23 MUSIC 1 IN LEFT	22 DISCRETE 5 INPUT* (PLAY KEY)	21 GROUND	20 DISCRETE 4 INPUT* (COM SWAP)	19 RESERVED	18 RESERVED	17 RESERVED	16 PILOT HEADSET AUDIO OUT LEFT
44 SPEAKER AUDIO OUT HI	43 SPEAKER AUDIO OUT LO	42 PASS 4 MIC AUDIO IN LO	41 PASS 4 MIC AUDIO IN HI	40 PASS 3 MIC AUDIO IN LO	39 PASS 3 MIC AUDIO IN HI	38 PASS 2 MIC AUDIO IN LO	37 PASS 2 MIC AUDIO IN HI	36 PASS 1 MIC AUDIO IN LO	35 PASS 1 MIC AUDIO IN HI	34 COPILOT MIC AUDIO IN LO	33 COPILOT MIC KEY* IN	32 COPILOT MIC AUDIO IN HI	31 PILOT HEADSET AUDIO OUT RIGHT	

Figure C-8 J2401 & J2402 Connector Layout Drawing

**GARMIN**<sup>®</sup>