

G5 Electronic Flight Instrument Installation Manual For Experimental/LSA Aircraft



© 2022
Garmin Ltd. or its subsidiaries
All Rights Reserved

Except as expressly provided herein, no part of this manual may be reproduced, copied, transmitted, disseminated, downloaded or stored in any storage medium, for any purpose without the express prior written consent of Garmin. Garmin hereby grants permission to download a single copy of this manual and of any revision to this manual onto a hard drive or other electronic storage medium to be viewed and to print one copy of this manual or of any revision hereto, provided that such electronic or printed copy of this manual or revision must contain the complete text of this copyright notice and provided further that any unauthorized commercial distribution of this manual or any revision hereto is strictly prohibited.

Garmin International, Inc.
1200 E. 151st Street
Olathe, KS 66062 USA

Garmin (Europe) Ltd.
Liberty House, Hounslow Business Park
Southampton, Hampshire SO40 9LR U.K.

AVIATION LIMITED WARRANTY

G5 warranty information is available at <https://www.garmin.com/en-US/legal/aviation-limited-warranty>.

RECORD OF REVISIONS

Revision	Revision Date	Description
6	01/28/20	Added GAD 29/29B, GMU 11, and GSA 28 info
7	05/11/20	Added Lightning Protection Module info
8	12/16/20	Added -01 Battery Pack info
9	09/13/21	Added -02 Battery Pack info
10	02/11/22	Added 011-03809-01 unit info

INFORMATION SUBJECT TO EXPORT CONTROL LAWS

This document may contain information which is subject to the Export Administration Regulations (“EAR”) issued by the United States Department of Commerce (15 CFR, Chapter VII Subchapter C) and which may not be exported, released or disclosed to foreign nationals inside or outside the United States without first obtaining an export license. The preceding statement is required to be included on any and all reproductions in whole or in part of this manual.

CURRENT REVISION DESCRIPTION

Revision	Page Number	Section Number	Description of Change
10	1-3	1.5.1	Updated G5 unit part numbers in Table 1-1
	3-11	3.7	Updated G5 unit part number in Figure 3-7

DEFINITIONS OF WARNINGS, CAUTIONS, AND NOTES



WARNING

A warning means injury or death is possible if the instructions are not obeyed.



CAUTION

A caution means that damage to the equipment is possible.



NOTE

A note gives more information.



WARNING

If these guidelines are not followed, the lithium-ion battery may experience a shortened life span or may present a risk of damage to the device, fire, chemical burn, electrolyte leak, and/or injury.

- *Do not leave the battery exposed to a heat source or in a high temperature environment. To help prevent damage, store the battery out of direct sunlight.*
- *For maximum battery longevity, store within a temperature range of -4° to 68°F (from -20° to 20°C).*
- *Do not use a sharp object to remove the battery.*
- *Do not disassemble, puncture, damage, or incinerate the device or battery.*
- *Keep the battery away from children.*
- *Only replace the battery with the approved replacement from Garmin. Using another battery presents a risk of fire or explosion. To purchase a replacement battery, see you Garmin dealer or the Garmin website.*
- *Contact your local waste disposal department to dispose of the device and battery in accordance with applicable local laws and regulations.*



WARNING

To reduce the risk of unsafe operation, carefully review and understand all aspects of the G5 Install Manual & Pilot's Guide documentation and the Pilot's Operating Handbook of the aircraft. Thoroughly practice basic operation before actual use. During flight operations, carefully compare indications from the G5 to all available flight displays. For safety purposes, always resolve any discrepancies.



WARNING

This product, its packaging, and its components contain chemicals known to the State of California to cause cancer, birth defects, or reproductive harm. This Notice is being provided in accordance with California Proposition 65. If you have any questions or would like additional information, please refer to our website at www.garmin.com/prop65

**CAUTION**

The display uses a lens with a special coating that may be sensitive to certain oils, waxes, and abrasive cleaners. CLEANERS CONTAINING AMMONIA WILL HARM THE ANTI-REFLECTIVE COATING. It is very important to clean the lens using a clean, lint-free cloth and a cleaner that is specified as safe for anti-reflective coatings. Avoid any chemical cleaners or solvents that can damage plastic components.

**CAUTION**

The G5 does not contain any user-serviceable parts. Repairs should only be made by an authorized Garmin service center. Unauthorized repairs or modifications could result in permanent damage to the equipment and void both the warranty and the authority to operate this device under FAA, FCC, and other applicable regulations.

**NOTE**

The term LRU, as used throughout this manual is an abbreviation for Line Replaceable Unit. LRU is used generically in aviation for a product (such as a GSA 28 or GMC 307) that can be readily "swapped out" (usually as a single component) for troubleshooting/repair.

**NOTE**

References to the GMC Mode Controller throughout this manual apply equally to the GMC 305, GMC 307, and GMC 507 except where specifically noted.

**NOTE**

Use of the G5 Version 2 or 3 Battery (011-03893-01 or -02) requires G5 system software v6.80 or later. It is recommended to update software before installing this battery. To download the latest approved software visit: <https://support.garmin.com/en-US/>.

SOFTWARE LICENSE AGREEMENT FOR GARMIN AVIATION PRODUCTS

BY USING THE DEVICE, COMPONENT OR SYSTEM MANUFACTURED OR SOLD BY GARMIN (“THE GARMIN PRODUCT”), YOU AGREE TO BE BOUND BY THE TERMS AND CONDITIONS OF THE FOLLOWING SOFTWARE LICENSE AGREEMENT. PLEASE READ THIS AGREEMENT CAREFULLY. Garmin Ltd. and its subsidiaries (“Garmin”) grants you a limited license to use the software embedded in the Garmin Product (the “Software”) in binary executable form in the normal operation of the Garmin Product. Title, ownership rights, and intellectual property rights in and to the Software remain with Garmin and/or its third-party providers. You acknowledge the Software is the property of Garmin and/or its third-party providers and is protected under the United States of America copyright laws and international copyright treaties. You further acknowledge the structure, organization, and code of the Software are valuable trade secrets of Garmin and/or its third-party providers and the Software in source code form remains a valuable trade secret of Garmin and/or its third-party providers. You agree not to reproduce, decompile, disassemble, modify, reverse assemble, reverse engineer, or reduce to human readable form the Software or any part thereof or create any derivative works based on the Software. You agree not to export or re-export the Software to any country in violation of the export control laws of the United States of America.

TABLE OF CONTENTS

PARAGRAPH	PAGE
1 Installation Information	1-1
1.1 Introduction	1-1
1.2 G5 Overview.....	1-1
1.3 Inventory of Materials	1-2
1.4 Unpacking the Unit.....	1-2
1.5 Garmin Equipment	1-3
1.6 Non-Garmin Equipment	1-4
1.7 Garmin Software and Documents.....	1-4
2 Installation Preparation.....	2-1
2.1 Electrical Considerations.....	2-1
2.2 Wiring/Cabling Considerations	2-2
2.3 Mechanical Considerations.....	2-10
3 G5 Installation	3-1
3.1 Primary Functions.....	3-1
3.2 General Specifications.....	3-1
3.3 Installation Information	3-1
3.4 Unit Installation	3-3
3.5 Antennas	3-5
3.6 Mounting Instructions.....	3-6
3.7 Outline and Installation Drawings.....	3-10
4 GPS Antenna Installation.....	4-1
4.1 Non-Garmin Antennas.....	4-1
4.2 Garmin Antennas	4-1
5 G5 Pinout	5-1
5.1 J51 Connector	5-1
6 Connector Installation Instructions.....	6-1
6.1 Shield Block Installation Parts	6-1
6.2 Lightning Protection Module (LPM) Installation Parts.....	6-3
6.3 Shield Termination Technique – Method A.1 (Standard)	6-5
6.4 Shield Termination Technique – Method A.2 (Daisy Chain)	6-9
6.5 Shield Termination Technique – Method B.1 (Quick Term)	6-10
6.6 Shield Termination Technique – Method B.2 (Daisy Chain-Quick Term).....	6-13
6.7 Daisy Chain between Methods A.1 and B.1	6-14
6.8 Unit ID (Strapping).....	6-15
6.9 Splicing Signal Wires	6-16

7 Interconnect Drawings.....	7-1
8 G5 Configuration and Post Installation Checkout.....	8-1
8.1 Recommended Test Equipment.....	8-1
8.2 Configuration Mode	8-2
8.3 Software Loading Procedure	8-2
8.4 Configuration Pages	8-3
9 Troubleshooting.....	9-1
9.1 General Troubleshooting	9-1
9.2 SD Card Slot.....	9-2
9.3 Unit Communication Error	9-2
9.4 Air Data Troubleshooting.....	9-2
9.5 Attitude Failure Troubleshooting	9-2
9.6 Heading Failure Troubleshooting (with GMU 11).....	9-3
9.7 G5 Data Logging	9-3
9.8 Sending Troubleshooting Data to Garmin.....	9-3
10 Maintenance.....	10-1
10.1 G5 Air Data Periodic Maintenance	10-1
10.2 G5 Battery Periodic Maintenance.....	10-1
10.3 Return to Service Information	10-1
11 Performance Specifications/Licensing/Compliance	11-1
11.1 GPS Specifications	11-1
11.2 G5 Environmental Specifications	11-1
11.3 G5 Performance Specifications	11-2
11.4 RS-232 Text Output Format.....	11-3
Appendix A GAD 13 OAT Probe Interface Module Installation	A-1
A.1 Equipment Description	A-1
A.2 General Specifications	A-2
A.3 Mounting and Wiring Requirements	A-3
A.4 J131 Connector	A-5
A.5 Outline and Installation Drawings	A-7
Appendix B GAD 29/29B/29C/29D (ARINC 429 Adapter) Installation	B-1
B.1 Equipment Description	B-1
B.2 Equipment Available	B-2
B.3 General Specifications	B-3
B.4 Mounting and Wiring Requirements	B-3
B.5 Connector Pinout	B-4
B.6 Outline and Installation Drawings	B-8

Appendix C GMC 507 (AFCS Mode Controller) Installation C-1

- C.1 Equipment Description C-1
- C.2 General Specifications C-2
- C.3 Mounting and Wiring Requirements C-2
- C.4 J7001 Connector C-4
- C.5 Outline and Installation Drawings C-7

Appendix D GMU 11 (Magnetometer) Installation D-1

- D.1 Equipment Description D-1
- D.2 Equipment Available D-2
- D.3 General Specifications D-2
- D.4 Unit Installation D-3
- D.5 J441 Connector D-5
- D.6 Outline and Installation Drawings D-6

Appendix E GSA 28 (AutoPilot Servo) Installation E-1

- E.1 Equipment Description..... E-1
- E.2 Equipment Available..... E-2
- E.3 General Specifications E-2
- E.4 Required Equipment..... E-4
- E.5 Unit Installation..... E-5
- E.6 Unit Wiring E-16
- E.7 Outline and Installation Drawings E-16
- E.8 Connector Pins E-43

1 INSTALLATION INFORMATION

1.1 Introduction

This manual is intended to provide mechanical and electrical information for use in the planning and design of an installation of the Garmin G5 into an aircraft. This manual is not a substitute for an approved airframe-specific maintenance manual, installation design drawing, or complete installation data package. Attempting to install equipment by reference to this manual alone and without first planning or designing an installation specific to your aircraft may compromise your safety and is not recommended. The content of this manual assumes use by competent and qualified avionics engineering personnel and/or avionics installation specialists using standard aviation maintenance practices in accordance with Title 14 of the Code of Federal Regulations and other relevant accepted practices. This manual is not intended for use by individuals who do not possess the competencies and abilities set forth above.



NOTE

Garmin recommends installation of the G5 by a Garmin-authorized installer. To the extent allowable by law, Garmin will not be liable for damages resulting from improper or negligent installation of the G5. For questions, please contact Garmin Product Support at 1-888-606-5482.

1.2 G5 Overview

The G5 is an electronic instrument display capable of operating as a standalone flight display or a fully integrated backup instrument for G3X™ systems. It features a bright, sunlight readable, 3.5-inch color display which is sized to fit in a standard 3-1/8-inch instrument cutout. With integrated attitude/air data sensors and GPS, the G5 replaces traditional electromechanical standby instruments by combining essential information into one easy-to-read display. The G5 seamlessly integrates with other G5 units in the same aircraft and with G3X systems using the CAN network. When installed as part of a G3X system, the G5 provides a redundant source of attitude and air data to the G3X displays, and additionally provides backup autopilot control allowing coupled GPS approaches to be flown or continued in the event the primary flight display is unavailable. When installed as a standalone system, the G5 can also perform the autopilot function. In the case of aircraft power loss, the optional battery backup sustains the G5 flight display with up to 4 hours of emergency power.



Figure 1-1 G5 Bezel Overview

1.3 Inventory of Materials

This manual provides (and provides references to) mechanical and electrical information required for the installation of the G5. This manual is intended to be a step-by-step guide to the installation, therefore it is important the steps in all sections be performed in order. All materials that are required/optional for the installation of the G5 are listed in this section (as such, some of the information in this section is repeated in following sections).

Before beginning the G5 installation, it is recommended the installer perform a complete inventory of all materials listed in this section (some materials are optional and may not be applicable to the installation). Section 1 should be used to verify that all components ordered from Garmin have been delivered correctly, and to identify any required materials that are not provided by Garmin.

1.4 Unpacking the Unit

Carefully unpack the equipment and make a visual inspection of all contents for evidence of damage incurred during shipment. If any component of the G5 is damaged, notify the carrier and file a claim. To justify a claim, save the original shipping container and all packing materials. Do not return any equipment to Garmin until the carrier has authorized the claim.

Retain the original shipping containers for storage. If the original containers are not available, a separate cardboard container should be prepared that is large enough to accommodate sufficient packing material to prevent movement.

1.5 Garmin Equipment

1.5.1 G5 Installation Equipment

Table 1-1 G5 Installation Equipment

LRU	Assembly Part Number	Unit Only Part Number
G5, Unit Only, Experimental/ LSA Aircraft	010-01485-01	011-03809-01
Installation Kit, G5	010-12493-10	011-03892-00
Installation Kit, G5, w/LPM	010-12493-11	011-03892-01
Battery Pack, G5	010-12493-00	011-03893-00
Battery Pack, G5, Version 2	010-12493-01	011-03893-01
Battery Pack, G5, Version 3	010-12493-02	011-03893-02

1.5.2 Optional GPS Antenna

The G5 includes a built-in GPS receiver with an internal antenna that can be used in many installations. A Garmin or non-Garmin GPS antenna is optional for G5 installations when not using the G5's internal GPS antenna. See [Section 4](#) for supported antennas and antenna requirements.

1.5.2.1 Antenna Brackets/Doubler Plates

See the G3X/G3X Touch™ Installation Manual (190-01115-01) for detailed information.

1.5.3 Optional Garmin LRUs

The G5 can be installed in a standalone configuration or as part of the G3X system. Optional Garmin LRUs (Line Replaceable Units) that can be installed with the G5 in the standalone configuration are listed below. If any of these LRUs are to be used in this installation, verify that all required installation materials such as connector kits have been acquired. Refer to the G3X/G3X Touch Installation Manual (190-01115-01) available at <https://support.garmin.com/support/manuals> for additional installation information for the G3X system.

Optional Garmin LRUs:

- GAD 13 OAT Probe Interface Module
- GAD 29 ARINC 429 Adapter (required for connection to IFR Navigator)
- GMC 305 Mode Controller
- GMC 307 Mode Controller
- GMC 507 Mode Controller
- GMU 11 Magnetometer
- GSA 28 Autopilot Servo

1.6 Non-Garmin Equipment

1.6.1 Wiring/Cabling Considerations

The installer will provide all wiring and cabling unless otherwise noted.

1.6.2 Contact and Crimp Tools

Recommended crimp tools used to build the wiring harnesses for the G5 are listed in Table 1-2. Equivalent crimp tools may also be used.

Table 1-2 Pin Contact and Crimp Tools Part Numbers

Contact Type	Garmin Contact Part Number	Recommended Positioner	Recommended Insertion/Extraction Tool	Recommended Hand Crimping Tool
Socket, Size 20, 20-24 AWG	336-00022-02	M22520/2-08, Daniels K13-1	M81969/1-04 for size 22D pins and M81969/1-02 for size 20 pins	M22520/2-01, Daniels AFM8



NOTE

Non-Garmin part numbers shown are not maintained by Garmin and consequently are subject to change without notice.

1.6.3 BNC Connectors

BNC connectors may be required to terminate the GPS antenna cable, depending upon which antenna is used. Check the GPS antenna installation instructions for detailed information.

1.6.4 Hex Driver

A 3/32" hex drive tool is required to secure the G5 to the panel as described in [Section 3](#), G5 Installation.

1.6.5 SD Card

A microSD™ card can be used with the G5 for software updates and data logging. Garmin recommends SanDisk® brand SD cards up to 32 GB.

1.6.6 Pneumatic Hoses and Connectors

Air hoses and fittings are required to connect pitot and static air to the G5. The G5 has a female 1/8-27 ANPT fitting for each pitot and static port. Use appropriate aircraft fittings to connect to pitot and static system lines.

1.6.7 Silicone Fusion Tape

Use Garmin Part Number 249-00114-00 or similar to wrap the wiring/cable bundles.

1.7 Garmin Software and Documents

The G5 unit software and a panel cut-out DXF file are available for free download from <http://www8.garmin.com/support/collection.jsp?product=010-01485-00>.

2 INSTALLATION PREPARATION

This section provides electrical and mechanical information needed for planning the physical layout of the G5 installation. Use the information in Section 2 to become familiar with all aspects of the installation before actually beginning the physical installation of any equipment into the aircraft. Garmin recommends the installer become familiar with all sections of this document before beginning the installation. In general terms, the below steps are recommended to be followed in order.

1. Inventory of all needed parts
2. Planning/layout of the installation
3. Installation of LRUs, antennas, and sensors
4. Construction of wiring harness, cables, and connectors
5. Software installation/configuration
6. Post-installation checkout procedure and calibration

2.1 Electrical Considerations

This section presents information required for planning the electrical layout of the G5 installation.



CAUTION

To avoid damage to the G5 and other LRUs, take precautions to prevent Electro-Static Discharge (ESD) when handling connectors and associated wiring. ESD damage can be prevented by touching an object that is of the same electrical potential as the LRU before handling the LRU itself.

2.1.1 Power Specifications

The G5 is capable of operating at either 14 or 28 VDC. Table 2-1 lists the supply voltage and current draw information for the G5. Use this information when determining power supply requirements. All installed electrical appliances must be considered when determining total power requirements.

The specified current draw listed in Table 2-1 is measured with the display backlight set to 100%.

Table 2-1 G5 Power Requirements

Configuration	14 V (Maximum)	14 V (Typical)	28 V (Maximum)	28 V (Typical)
G5 Only	3.5 W, 0.250 Amp	2.8 W, 0.200 Amp	3.5 W, 0.125 Amp	2.8 W, 0.100 Amp
G5 w/Battery	10.7 W, 0.760 Amp	2.8 W, 0.200 Amp	10.7 W, 0.380 Amp	2.8 W, 0.100 Amp

2.2 Wiring/Cabling Considerations

[Section 5](#) lists the pin information for the G5 and [Section 7](#) contains interconnect drawings. It is recommended that all LRUs be installed before constructing the wiring harnesses and cables.

Use MIL-W-22759/16 (or other approved wire) AWG #22 or larger wire for all non-shielded connections unless otherwise specified. Use MIL-C-27500 (or other approved wire) AWG #22 or larger wire for all shielded connections unless otherwise specified. The supplied standard pin contacts are compatible with up to AWG #20 wire. In cases where some installations have more than one LRU sharing a common circuit breaker, sizing and wire gauge is based on aircraft circuit breaker layout, length of wiring, current draw on units, and internal unit protection characteristics.

RG400 or RG142 coaxial cable with 50 Ω nominal impedance and meeting applicable aviation regulations should be used when installing an optional external GPS antenna.

2.2.1 Wiring Harness Installation

Use cable meeting the applicable aviation regulation for the interconnect wiring. Any cable meeting specifications is acceptable for the installation. Use the following precautions when routing cables:

- All cable routing should be kept as short and as direct as possible.
- Check there is ample space for the cabling and mating connectors.
- Avoid sharp bends in cabling.
- Avoid routing near aircraft control cables.
- Avoid routing cables near heat sources, RF sources, EMI interference sources, power sources (e.g. 400 Hz generators, trim motors, etc.) or near power for fluorescent lighting.
- Route the GPS antenna cable as far as possible away from all COM transceivers and other antenna cables.

The installer shall supply and fabricate all of the cables. Electrical connections are made through the D subminiature connector. [Section 5](#) defines the electrical characteristics of all input and output signals. Required connectors and associated hardware are supplied with the connector kit.

Contacts for the connectors must be crimped onto the individual wires of the aircraft wiring harness.

[Table 1-2](#) lists contact part numbers (for reference) and recommended crimp tools.



CAUTION

Check wiring connections for errors before connecting any wiring harnesses. Incorrect wiring could cause internal component damage.

2.2.2 CAN Bus Considerations

The primary digital interface used to exchange data between the G5 and other LRUs is the Controller Area Network, also known as the CAN bus. CAN was developed by Bosch GmbH in the 1980s, and its specifications are currently governed by ISO 11898-2. CAN is widely used in aviation, automotive, and industrial applications due to its simplicity and reliability.

2.2.3 CAN Bus Architecture

The electrical architecture of the CAN bus takes the form of a linear “backbone” consisting of a single twisted wire pair with an LRU connected (terminated) at each end (Figure 2-1). The overall length of the CAN bus from end to end should be 66 feet (20 meters) or less. At each of the two extreme ends of the CAN bus, a 120 Ω resistor is installed to “terminate” the bus. Termination resistors are provided either within the LRUs themselves, or using termination adapters that plug into an LRUs CAN connection (see [Section 2.2.5](#)).

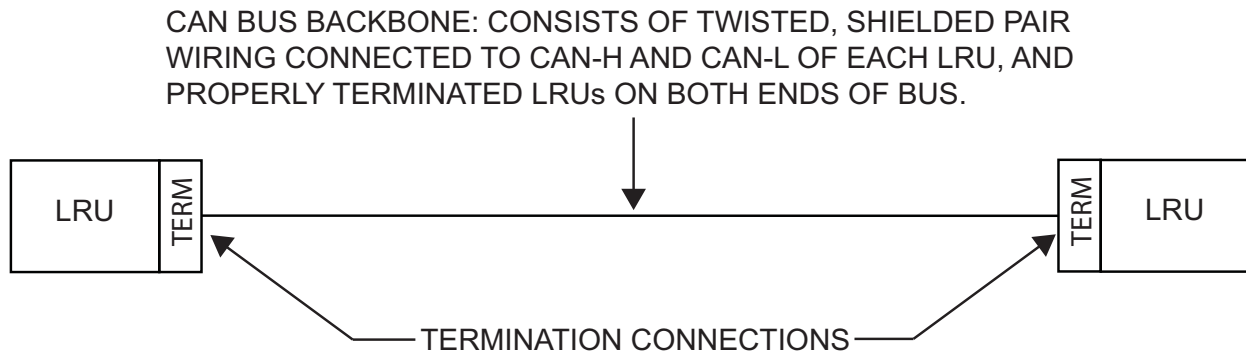

Figure 2-1 CAN Bus Backbone

Multiple LRUs may be connected in a daisy chain manner along the backbone of the CAN bus (Figure 2-2).

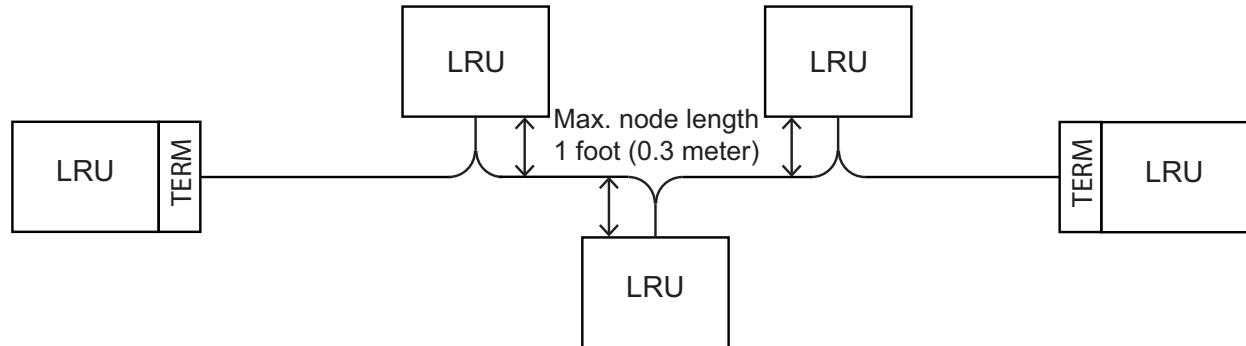
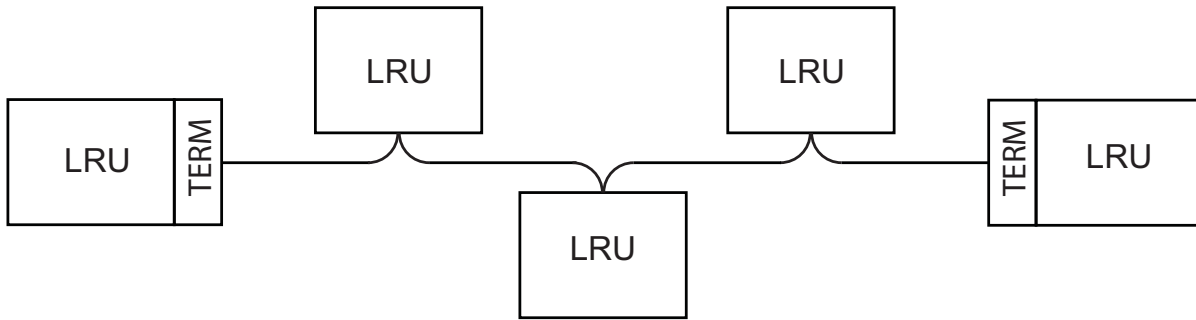

Figure 2-2 CAN Bus Node Connections

Daisy-chained LRUs (LRUs not at the extreme ends of the CAN bus) connect to the CAN backbone through short “stub” or “node” connections (Figure 2-3). The length of each node connection should be kept as short as possible, and should not exceed 1 foot (0.3 meter). The best way to connect devices between the ends of the CAN bus while maintaining short stub node lengths is to splice the connections as close to the device as practical. Unshielded wire sections should be kept as short as practical.

Multiple devices must not connect to the CAN bus backbone at the same point. Rather than splicing two or more stub node connections together, the CAN bus should instead be daisy-chained from one device to the next (Figure 2-3).



LINEAR CAN BACKBONE, DAISY-CHAINED CONNECTIONS WITH SHORT STUB NODE LENGTHS. MULTIPLE LRUs ARE NOT CONNECTED TO THE BACKBONE AT THE SAME LOCATION.

Figure 2-3 Correct CAN Wiring Example

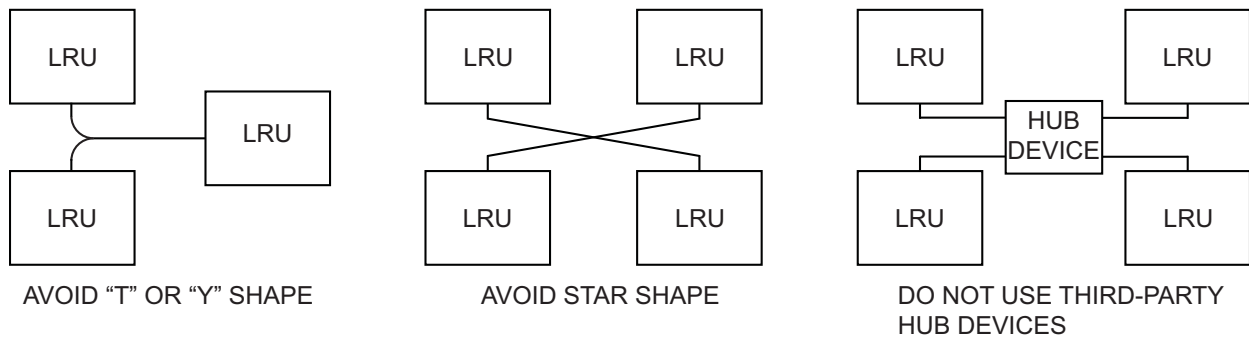
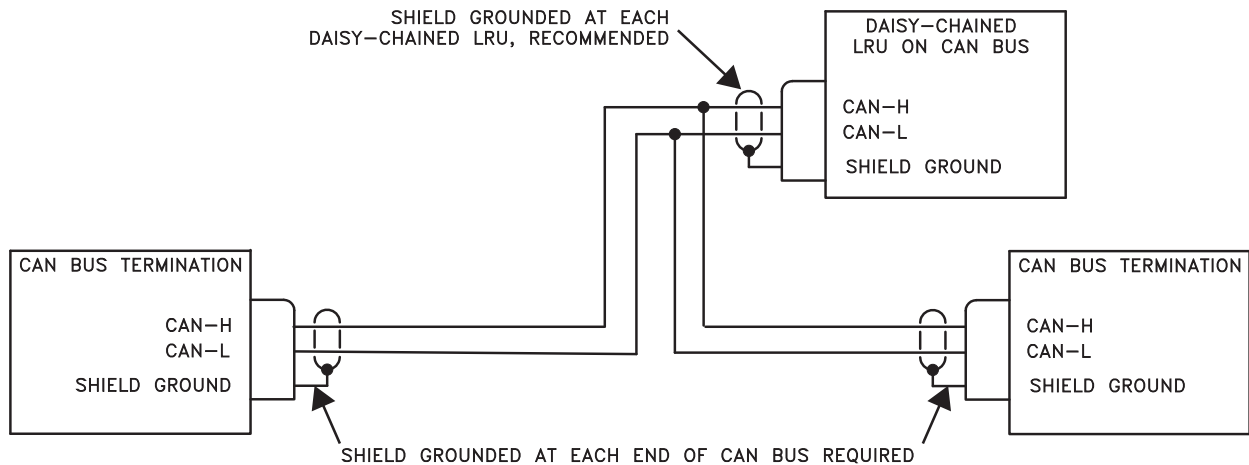

Figure 2-4 Incorrect CAN Wiring Example

2.2.4 CAN Bus Wiring

Wiring used for the CAN bus should be shielded twisted-pair cable, MIL-C-27500 or equivalent. 22 AWG or larger wire is recommended for physical robustness and ease of installation. The shields for each CAN bus wire segment should be interconnected, forming a continuously connected shield from one end of the CAN bus to the other (Figure 2-5). At a minimum, the CAN bus shield should always be grounded to the device connector backshells at the two extreme ends of the bus, but it is recommended to also ground the shield at all other devices on the CAN bus.



CAN-H AND CAN-L WIRING SHOWN IS TWISTED SHIELDED PAIR

Figure 2-5 CAN Bus Shield Grounding

For proper CAN bus operation, it is important for all devices on the CAN bus to share a common power ground reference. Connect all LRU power ground pins to a single common ground point - do not use local ground points or use the aircraft structure as a ground return path.

2.2.5 CAN Bus Termination

At each of the two extreme ends of the CAN bus backbone, a 120 Ω resistor is installed to terminate the bus. Separate resistors are not required, termination resistors are provided either within the LRUs themselves, or using termination adapters that plug into an LRU's CAN connection.

- The GAD 13, GAD 29, GMU 11, GPS 20A, and G5 installation kits each provide a 9-pin termination adapter that provides CAN bus termination when attached between the LRU and the cable assembly. The termination adapter contains a 120 Ω resistor that is connected between pins 1 and 2 (Figure 2-6).
- The GMC 507 and GSA 28 contain a 120 Ω resistor inside the unit that provides termination when the two CAN-TERM pins are connected together ([Figure 2-7](#)).

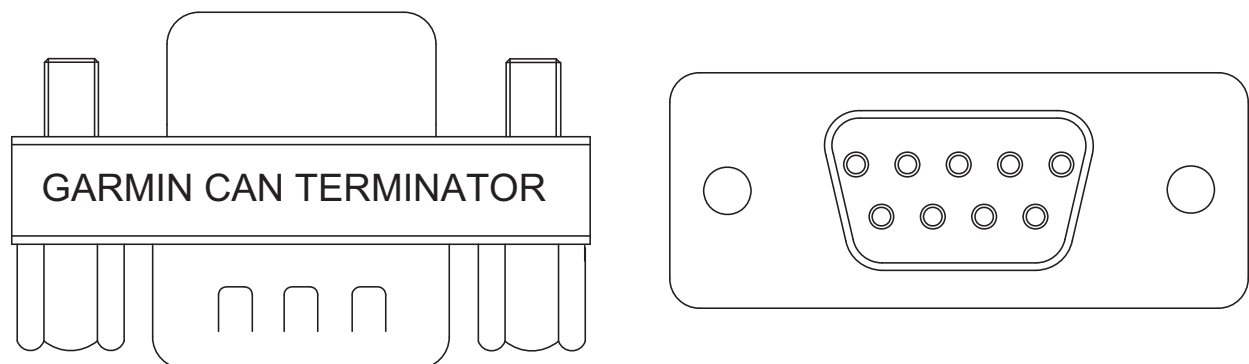

Figure 2-6 CAN Bus Termination (011-02887-00) for the G5, GAD 13, GAD 29, GMU 11, and GPS 20A

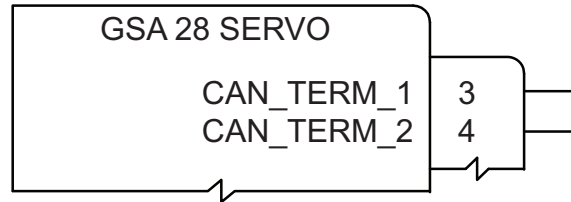
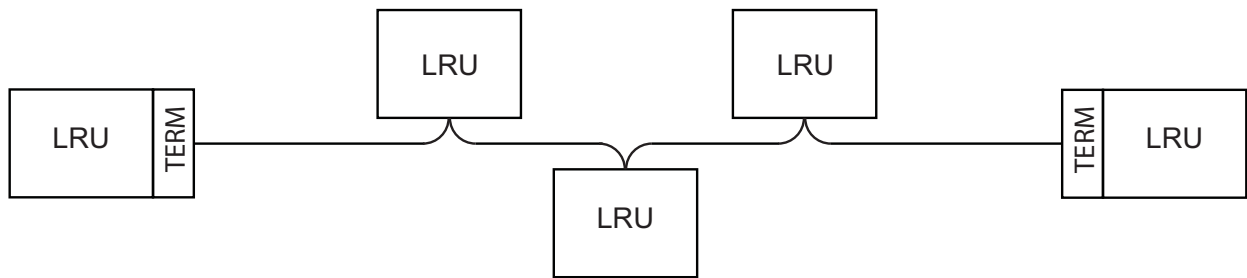

Figure 2-7 CAN Bus Termination for the GSA 28

Both ends of the CAN bus should be terminated (Figure 2-8) and devices that are not at the ends of the CAN bus should not be terminated (Figure 2-9).



CORRECT - CAN BUS TERMINATED AT EACH END OF THE BACKBONE

Figure 2-8 Correct CAN Bus Termination Example

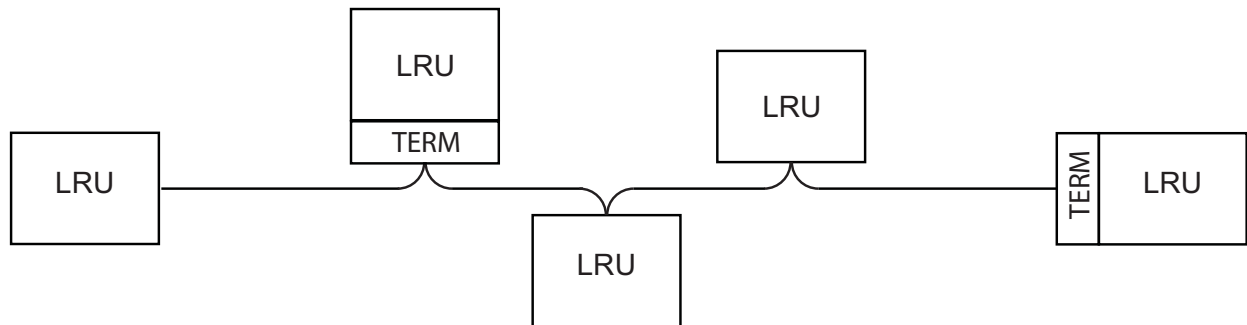

INCORRECT - ONE OF THE TERMINATIONS IS NOT AT THE END OF THE BACKBONE

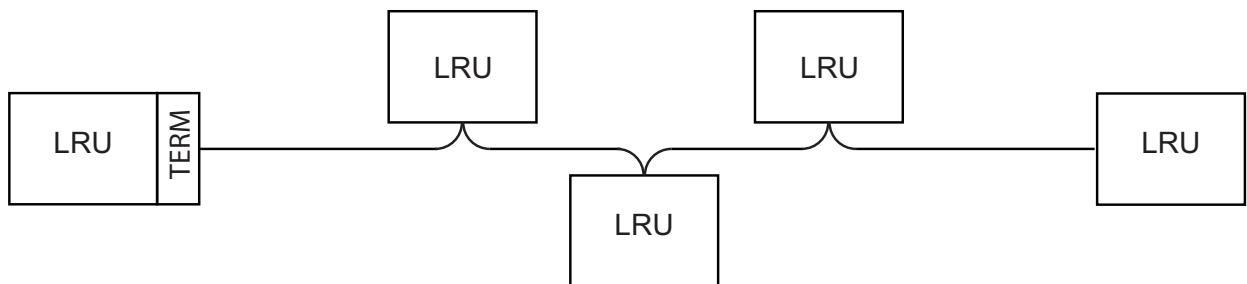

INCORRECT - ONLY ONE END OF THE BACKBONE IS TERMINATED

Figure 2-9 Incorrect CAN Bus Termination Example

2.2.6 CAN Bus LRU Removal Guidelines

The following should be considered when removing an LRU from the ends of the CAN bus.

- GAD 13, GAD 29, GMU 11, GPS 20A, G5, or other devices that use the 9-pin CAN termination adapter: The CAN bus will remain terminated as long as the CAN termination adapter is left connected to the cable assembly.
- GMC 507: The CAN Bus will be unusable until the LRU is reconnected or the bus is properly terminated at both ends of the CAN backbone.
- GSA 28: A removal adapter (part number 011-03158-00) is provided with each GSA 28 connector kit. This adapter can be used when a GSA 28 is removed from the aircraft. The removal adapter keeps the node on the CAN bus in the same state as when the servo was installed (either terminated or un-terminated). The removal adapter also allows trim signals to pass through when no servo is installed.

2.2.7 CAN Bus Installation Guidelines

For maximum reliability of the CAN bus, the following guidelines should be followed:

- The CAN bus backbone must be a single linear path with exactly two distinct ends. CAN bus connections should be daisy-chained from device to device. Avoid “T”, “Y”, and "star" topologies, and do not use a hub device ([Figure 2-4](#)).
- The overall length of the bus should not exceed 66 feet (20 meters).
- Keep all stub node connections as short as practical. The maximum length of any stub node connection is 1 foot (0.3 meter).
- Avoid connecting more than one device to the CAN bus backbone at the same point. Instead, daisy chain the CAN bus backbone from one device to the next.
- Follow proper wiring, shielding, and grounding requirements described in [Section 2.2.2](#).
- Terminate the CAN bus at the two extreme ends of the bus, as described in [Section 2.2.3](#).
- When adding a new device to the CAN bus, evaluate proposed modifications to the CAN bus wiring connections to ensure compliance with all of the preceding requirements.

2.2.8 CAN Bus Troubleshooting

The CAN bus is very simple, and a properly installed CAN bus is very reliable. If problems are occurring, the following steps can help to identify the issue.

1. Review the status LED of devices on the CAN bus such as the GSA 28 servos. The status LED indications are listed in Table 2-2.

Table 2-2 Status LED Indications

LED Indication	Description
No Light	No power
Steady Green	On but not communicating through CAN bus
Flashing Green	On and communicating through CAN bus
Red	Hardware fault
Alternating Red/Green	CAN bus network error (two identical LRUs are configured with the same unit ID)

2. Make sure the CAN bus is daisy-chained between CAN devices around the system, and that CAN devices are not connected using a single point (star topology) or routed through a hub device. This

can cause unwanted signal reflections and “orphan” some devices on the bus and prevent their communication.

3. Make sure the CAN bus is terminated in only two locations, and only at the extreme ends of the CAN bus.
4. With power removed, remove the CAN bus connector from one of the devices that is not located at either of the extreme ends of the CAN bus.
 - a) Using an ohm meter, verify the resistance between the CAN-H and CAN-L pins on the connector is 60 Ω. This will verify the CAN backbone is properly terminated at each end (two 120 Ω terminating resistors in parallel).
 - b) A resistance of 120 Ω indicates that one of the two required CAN terminations is missing.
 - c) A resistance of 40 Ω or less indicates that too many terminations are installed.
5. Verify the CAN-H and CAN-L signals are not swapped, shorted together, or open-circuited at any LRU connector.
6. Verify the CAN-H and CAN-L signals are not shorted to ground (this can happen when shielded wire is installed incorrectly).
7. Highlight each device on the configuration mode Device Information page and verify the value displayed for Network Error Rate is a steady 0%.

ARINC 429 Interface Information	
Product Name	GAD 29
Software Version	2.30
Network Error Rate	✓ 0%
Serial Number	366000561

Figure 2-10 Network Error Rate

8. Start only the #1 G5 unit and one other CAN device at a time, and verify the connection quality for each device. Sometimes a device will communicate only when it is the only powered device on the CAN bus, if one or more of the above issues is present. Evaluating each CAN device in turn can help narrow down a problem.
9. It is very important for each device on the CAN bus to share a common power/signal ground. Ground potential differences between devices on the CAN bus can cause communication errors. Ground devices to a common ground bus, not to the airframe or to multiple grounding buses.

10. Advanced CAN diagnostics are available by selecting Device Information, Diagnostics, CAN Network. Any increase of these parameters above zero is an indication of a CAN bus issue.



Figure 2-11 CAN Diagnostic Page

2.2.9 Cable Connector Installation

A coaxial cable connection is required for the optional external GPS antenna.

1. Route the coaxial cable to the unit location. Secure the cable in accordance with good aviation practices.
2. Trim the coaxial cable to the desired length and install the BNC connector. If provided, follow the connector manufacturer's instructions for cable preparation.

2.3 Mechanical Considerations

This section presents all information required for planning the physical layout of the G5 installation.

2.3.1 Physical Specifications

Table 2-3 lists panel requirements. All width, height, and depth measurements are taken with unit mounting ring and connectors (if applicable).

Table 2-3 G5 Physical Specifications

Configuration	Width	Height	Depth*	Unit Weight	Total Weight**
G5	3.42 in	3.60 in	2.61 in	0.6 lb	0.7 lb
G5 with Battery***	3.42 in	3.60 in	3.03 in	0.8 lb	1.0 lb

*Depth behind aircraft panel

**Weight includes connector and mounting ring (011-03892-00/-01 installation kit)

***Applies to 011-03893-00/01/02 battery packs

2.3.2 Cooling Requirements

While no forced cooling air is required for the G5, it is highly recommended the air behind the panel be kept moving (by ventilation or a fan). Units tightly packed in the avionics stack heat each other through radiation, convection, and sometimes by direct conduction. Even a single unit operates at a much higher temperature in still air than in moving air. Fans or some other means of moving the air around electronic equipment are usually a worthwhile investment.



NOTE

Avoid installing LRUs near heat sources. If this is not possible, ensure that additional cooling is provided. Allow adequate space for installation of cables and connectors. The installer will supply and fabricate all of the cables. All wiring should be in accordance with FAA AC 43.13-1B and AC 43.13-2B.

2.3.3 Compass Safe Distance

After reconfiguring the avionics in the cockpit panel, if the unit is mounted less than 12 inches from the compass, recalibrate the compass and make the necessary changes for noting correction data.

3 G5 INSTALLATION

The G5 can be installed as a standalone flight display or a fully integrated backup instrument in the G3X™ system. This section contains general information as well as installation information for the G5.

3.1 Primary Functions

- Attitude (roll, pitch, and yaw)
- Air data (altitude and airspeed)
- Slip/skid and turn coordinator
- GPS (ground speed and ground track)
- Autopilot control (when installed with optional equipment)
- Optional battery backup with up to 4 hours of emergency power
- RS-232 and CAN communication interfaces
- Course and navigation display (when installed with optional equipment)
- Magnetic heading (when installed with optional equipment)

3.2 General Specifications

See [Section 2.1.1](#) for power/current specifications, and [Section 2.3.1](#) for dimension/weight specifications.

3.3 Installation Information

3.3.1 Required Equipment

One installation kit (Table 3-1) is required to install each G5 unit. The G5 mounting ring is included in the installation kit to mount the G5 to the aircraft panel and to reinforce the panel cutout in thin panel installations. The installation kit is not included with the G5.

An optional alternate installation kit is also available ([Table 3-3](#) and [Table 3-4](#)). This kit incorporates a lightning protection module (LPM) into the backshell of the D-sub. The LPM provides additional protection devices for the CAN signals and aircraft power 1 input.

Table 3-1 Contents of the G5 Installation Kit (011-03892-00)

Item	Garmin P/N	Quantity
Connector Kit, 9 Pin, w/CAN Term	011-03002-00	1
Mounting Ring, G5	115-02251-03	1
Screw, 6-32, 0.500"	211-60207-12	3

Table 3-2 Contents of the Connector Kit (011-03002-00)

Item	Garmin P/N	Quantity
Sub-Assy, Bkshl w/Hdw, Jackscrew, 9 pin	011-01855-00	1
Sub Assy, CAN Termination Kit	011-02887-00	1
Conn, Rcpt, D-Sub, Crimp Socket, 9 Ckt	330-00625-09	1
Contact, Sckt, D-Sub, Crimp, Size 20, 20-24 AWG	336-00022-02	9

Table 3-3 Contents of the G5 LPM Installation Kit (011-03892-01)

Item	Garmin P/N	Quantity
Connector Kit, 9 Pin, w/CAN Term, w/LPM	011-03002-20	1
Mounting Ring, G5	115-02251-03	1
Screw, 6-32, 0.500"	211-60207-12	3

Table 3-4 Contents of the LPM Connector Kit (011-03002-20)

Item	Garmin P/N	Quantity
Sub-Assy, Bkshl w/Hdw, Jackscrew, 9 pin, w/LPM**	011-01855-20	1
Sub Assy, CAN Termination Kit*	011-02887-00	1
Conn, Rcpt, D-Sub, Crimp Socket, 9 Ckt	330-00625-09	1
Contact, Sckt, D-Sub, Crimp, Size 20, 20-24 AWG	336-00022-02	9

*Not all items included in kit P/N 011-02887-00 are used in this installation

**See [Figure 6-2](#) for connector assembly. See [Figure 7-3](#) for LPM Wiring Interface

3.3.2 Additional Equipment Required

A 3/32" hex drive tool is required to secure the G5 to the panel as described in [Section 3.6.3](#) and shown in [Figure 3-4](#).

Air hoses and fittings are required to connect pitot air and static air to the G5. The G5 uses a female 1/8-27 ANPT fitting for each of these ports. Use appropriate aircraft fittings to connect to pitot and static system lines.

3.4 Unit Installation

Fabrication of a wiring harness is required. Sound mechanical and electrical methods and practices are recommended for installation of the G5. Refer to [Section 2.2](#) for wiring considerations, and to [Section 5](#) for pinouts.

Connector kits include backshell assemblies. Garmin's backshell connectors give the installer the ability to quickly and easily terminate shield grounds at the backshell housing. Instructions needed to install the Jackscrew Backshell and Shield Block Ground can be found in [Section 6](#).

3.4.1 Mounting Requirements

The G5 includes an extremely sensitive inertial measurement unit. Consider the following when selecting a mounting location:

- Mount the G5 with the connector aligned to within 15.0° of the longitudinal axis of the aircraft (display bezel parallel to the wing spar). Configuration allows for direct manual entry of the present yaw offset when the instrument panel to which the G5 is mounted is not perpendicular to the aircraft centerline.
- The G5 should be rigidly mounted to the aircraft panel. To avoid degraded accuracy, the aircraft panel should be rigid and panel flexing should be minimized.
- The G5 should be mounted to the aircraft panel with the connector facing toward the front of the aircraft.
- The G5 should be mounted within 13 feet (4 meters) longitudinally of the aircraft CG (center of gravity). In cases where the longitudinal distance from the CG is planned to be greater than 6.5 feet (2 meters), it is preferable to mount the G5 forward of the aircraft CG, if possible, to improve autopilot performance.
- To prevent degraded accuracy, avoid placing the G5 near areas that are prone to severe vibration.
- The G5 must be leveled to within 30.0° of the flight level cruise attitude. An aircraft leveling and offset calibration procedure must additionally be carried out before flight.
- The mounting location for the G5 should be protected from rapid thermal transients, in particular large heat loads from nearby high-power equipment.
- Avoid placing the G5 within 1 inch of magnetically mounted antennas, speaker magnets, or other strongly magnetic items.

3.4.2 Unit Mounting

For final installation and assembly, refer to the outline and installation drawings in [Section 3.7](#).

1. Mount the G5 in a suitable location using the installation kit ([Table 3-1](#)) per the requirements in Section 3.4.1.
2. Assemble the wiring harness and backshell connector.
3. Assemble the pneumatic hoses and connector.
4. Connect the CAN terminator if required (see [Section 2.2.5](#)).
5. Connect the backshell connector and hoses.

3.4.3 Pneumatic Plumbing

The G5 has two ports that are connected to the aircraft’s pitot and static pressure sources. The ports are labeled on the unit using the abbreviations “P” and “S” respectively (Figure 3-1). The pressure ports have 1/8-27 ANPT female threads. The mating fitting must have 1/8-27 ANPT male threads.



NOTE

The temporary port plugs attached to the pressure ports on a new G5 are not suitable for flight and must be removed before the installation of the G5 into the aircraft.



NOTE

In an installation with dual G5 units, pitot/static plumbing must be connected to both units.

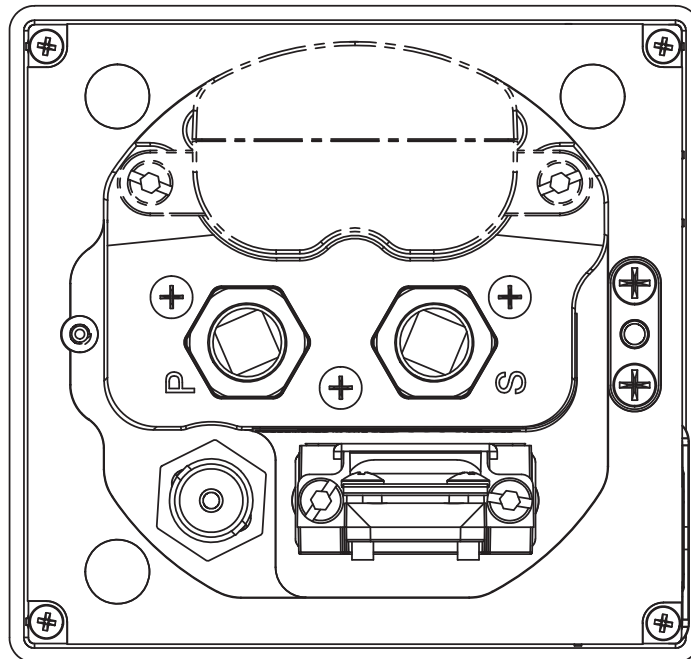

Figure 3-1 G5 Air Hose Fitting Locations

Use appropriate air hoses and fittings to connect the pitot and static lines to the unit. Avoid sharp bends in the tubing and attempt to route hoses away from aircraft control cables. The G5 should not be at the low point of the pneumatic plumbing lines to avoid moisture or debris collecting at or near the unit. Ensure that no deformations of the airframe surface have been made that would affect the relationship between static air pressure and true ambient static air pressure for any flight condition. Refer to CFR Part 43, Appendix E for approved practices while installing hoses and connections.



NOTE

A G5 installed as a standalone unit may optionally be configured to disable its internal air data sensors. In this case, no connection to the aircraft's pitot/static system is required. If not connected, the pitot/static fittings on the G5 should be covered with dust caps. A G5 with air data disabled does not support autopilot functionality.

3.4.4 Pneumatic Connections

The following steps should be used to aid in the fabrication of pneumatic hose connections and in attaching the aircraft pitot pressure source and aircraft static pressure sources to the G5.



NOTE

Whenever the aircraft is connected to a pitot-static tester, such as during Part 43 Appendix E altimeter tests, the pitot port must be covered by a pitot adapter that is controlled by the pitot-static tester. Failure to do so will result in overpressuring and damaging the internal airspeed sensor.



NOTE

Use of different colored tubing is recommended for static and pitot plumbing to avoid plumbing connection errors. Incorrect plumbing connections will result in erroneous air data information calculated by the G5.

Follow these cautions when connecting pneumatic lines:

1. Make sure the aircraft static pressure port is plumbed directly to the unit static pressure input port and the aircraft pitot pressure port is plumbed directly to the unit pitot pressure input port.
2. Seal the threads of pneumatic fittings at the connector ports. Use caution to ensure there are no pneumatic leaks.
3. Use care to avoid getting fluids or particles anywhere within the pneumatic lines connected to the G5.

3.5 Antennas

Refer to [Section 4](#) for antenna installation information.

3.6 Mounting Instructions

Refer to [Section 3.7](#) for outline and installation drawings.



NOTE

In addition to the mounting requirements listed in [Section 3.4.1](#), it is critical the G5 be installed with its display bezel perpendicular to the aircraft's longitudinal axis (display bezel parallel to the wing spar) and as close to level in the roll axis as possible. Small roll offsets, and pitch offsets up to 30°, can be corrected for during calibration.

3.6.1 Panel Cutout Template

The G5 Mounting Ring (115-02251-03) or [Figure 3-10](#) can be used as a template when marking the panel for cutout. See [Figure 3-9](#) for complete cutout dimensions (the dimensions on [Figure 3-9](#) are to verify the accuracy of the printout only).

3.6.2 Mounting Ring Installation

Secure the mounting ring to the aircraft panel using the supplied #6-32 pan head Phillips mounting screws. Evenly torque the mounting screws to 10-12 in-lb.

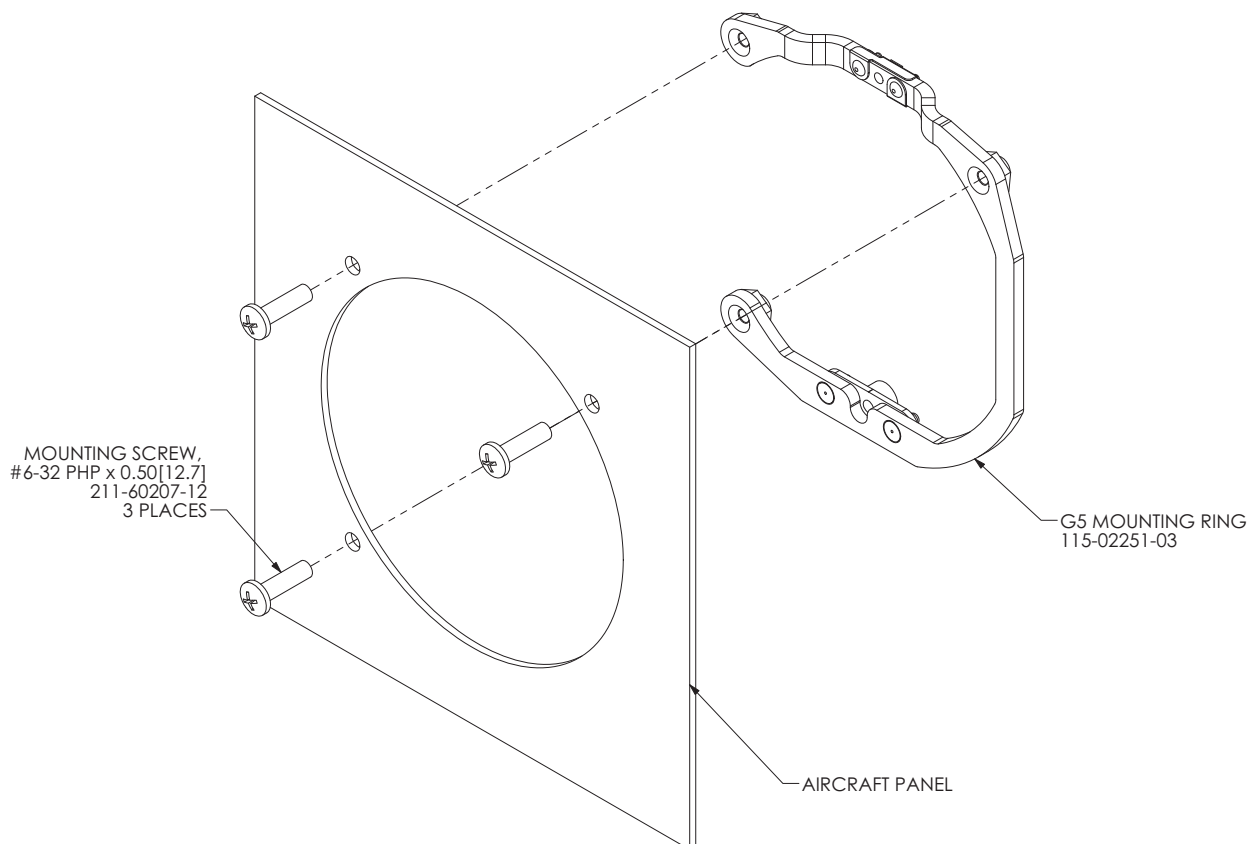

Figure 3-2 G5 Mounting Ring

3.6.3 Unit Installation

The G5 is installed by inserting the alignment pin located at the top of the unit into the mating hole in the mounting ring, pushing the unit flush with the instrument panel, and fastening the captive 3/32" hex socket head screw to the mounting ring as shown in [Figure 3-3](#). To fasten the captive screw to the mounting ring, insert a 3/32" hex drive tool through the access hole in the front cover of the G5 as shown in [Figure 3-4](#). Torque the captive mounting screw to 10-12 in-lb.

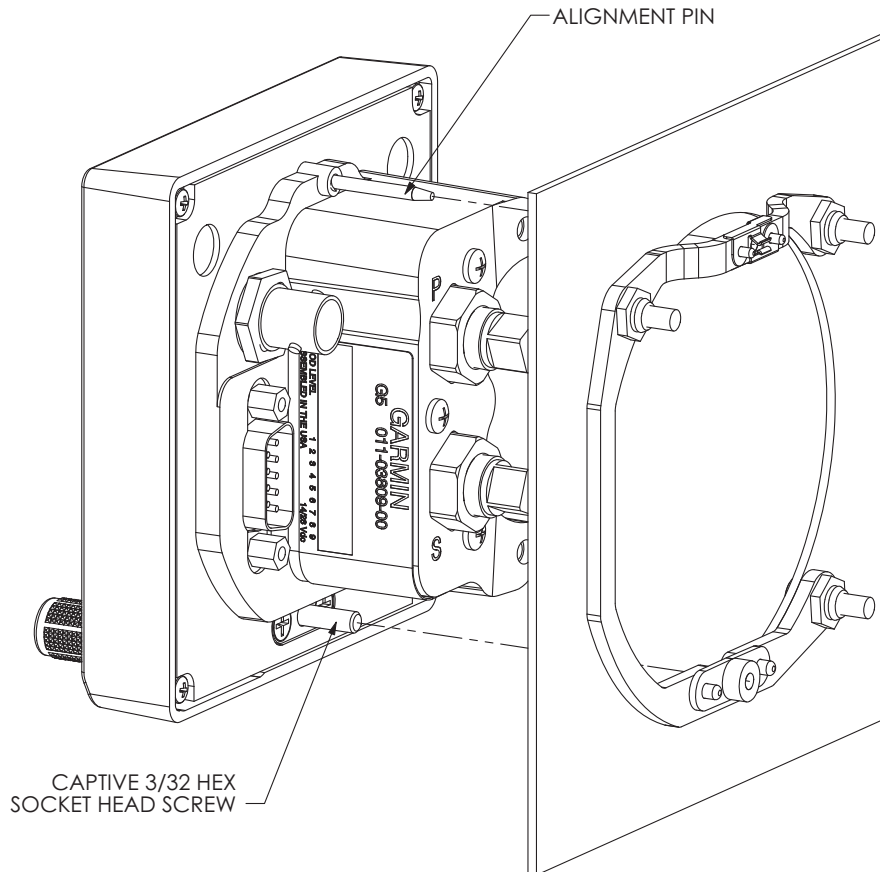

Figure 3-3 G5 Alignment Pin

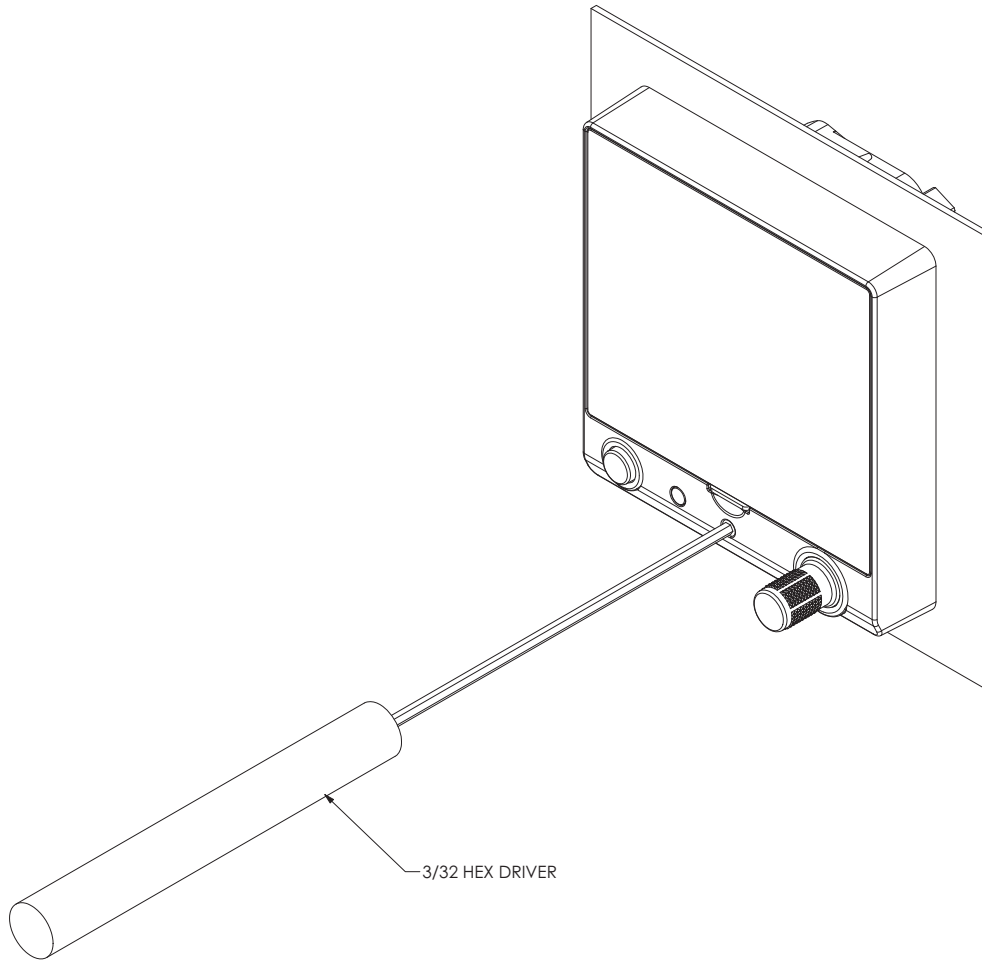

Figure 3-4 G5 Hex Driver Insertion

3.6.4 Captive Mounting Screw Replacement

The captive 3/32" hex socket head screw can be used for panel thicknesses up to 0.150 inch. For installations with a panel thickness greater than 0.150 inch, the captive mounting screw can be replaced with a standard #6-32 hex socket head screw. To replace the screw, remove the two #4-40 flat head Phillips mount plate screws, the G5 screw mount plate, and the captive screw as shown in [Figure 3-5](#). Reverse this process to install the longer #6-32 hex socket head screw. Ensure correct orientation of the screw mount plate before applying 6-8 in-lb of torque to the #4-40 mount plate screws.



NOTE

Standard #6-32 hex socket head screws use a 7/64" hex drive feature. The access hole in the G5 bezel is large enough to accommodate this increase in hex tool size.

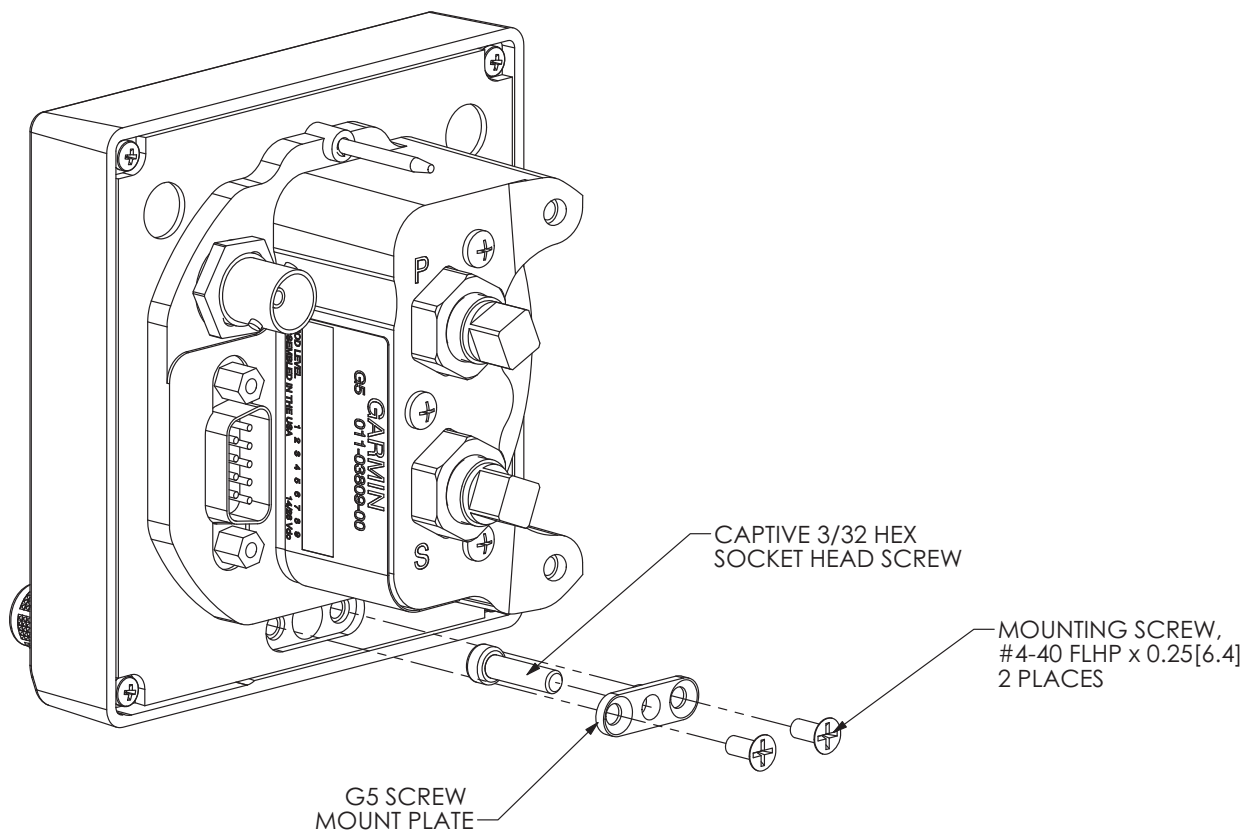
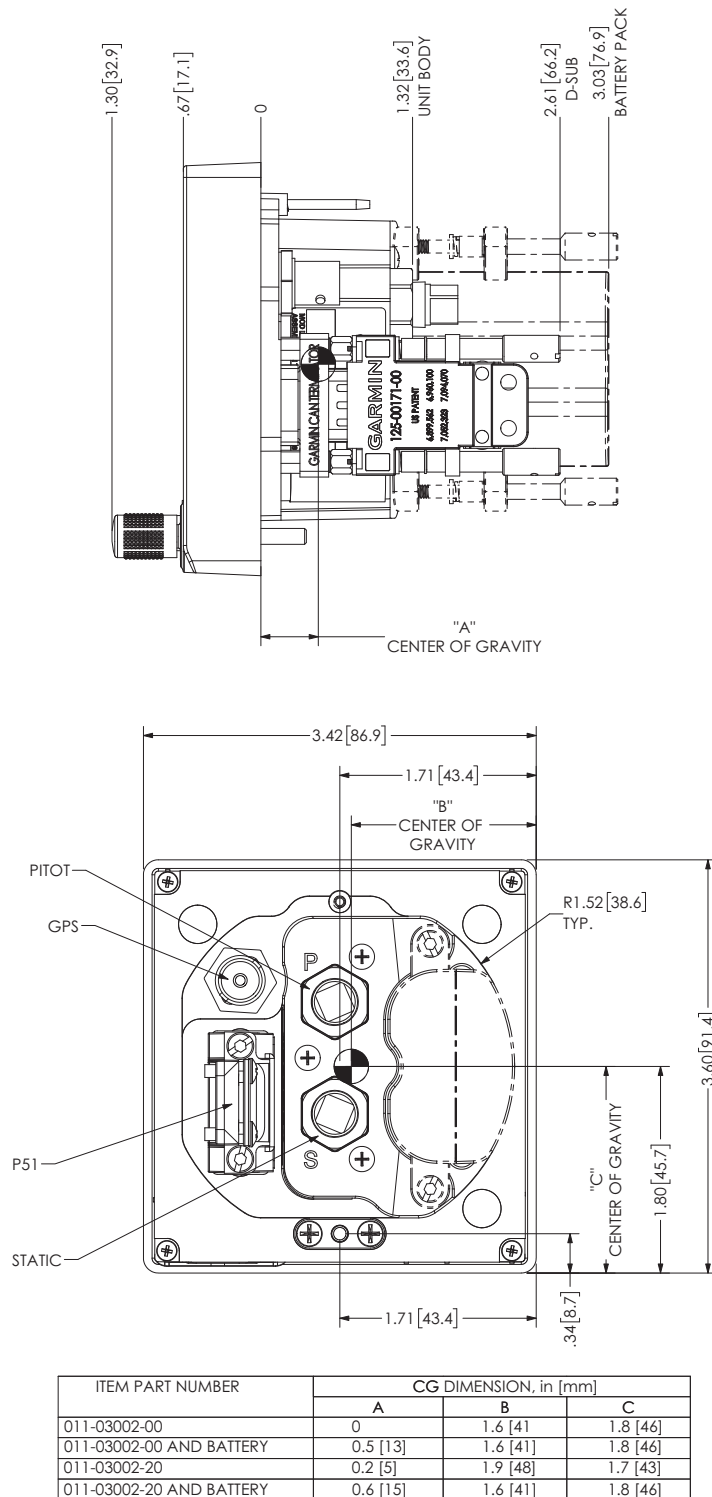

Figure 3-5 G5 Mounting Screw Replacement

3.7 Outline and Installation Drawings



NOTES:
 1-1. DIMENSIONS: INCHES[mm]. METRIC VALUES ARE FOR REFERENCE ONLY.
 1-2. DIMENSIONS ARE NOMINAL AND TOLERANCES ARE NOT IMPLIED UNLESS SPECIFICALLY STATED.

Figure 3-6 G5 Outline Drawing

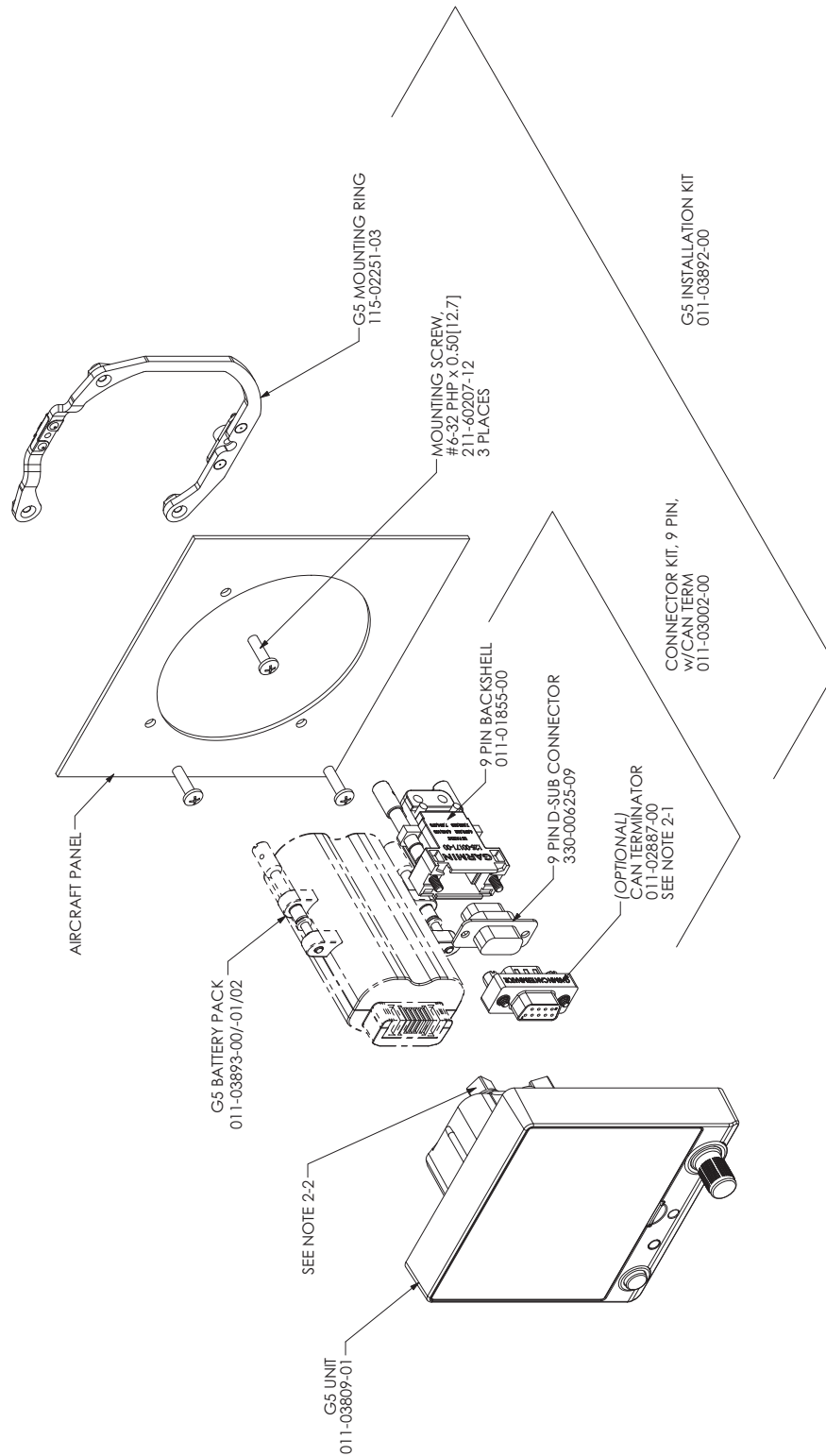

- NOTES:
- 2-1. DEPENDING ON HOW THE SYSTEM IS PHYSICALLY WIRED, THIS TERMINATOR MAY OR MAY NOT BE NEEDED IN THE INSTALLATION. THE CAN BUS MUST BE TERMINATED AT ONLY THE TWO MOST EXTREME POINTS ON THE CAN BACKBONE. IF USED WITH THE G3X SYSTEM REFER TO THE G3X INSTALL MANUAL FOR SPECIFIC GUIDANCE ON CAN BUS WIRING.
 - 2-2. ALL RED PLUGS MUST BE REMOVED AND DISCARDED. THEY ARE NOT TO BE USED FOR CAPPING AND SEALING UNUSED PORTS.

Figure 3-7 G5 Installation Drawing

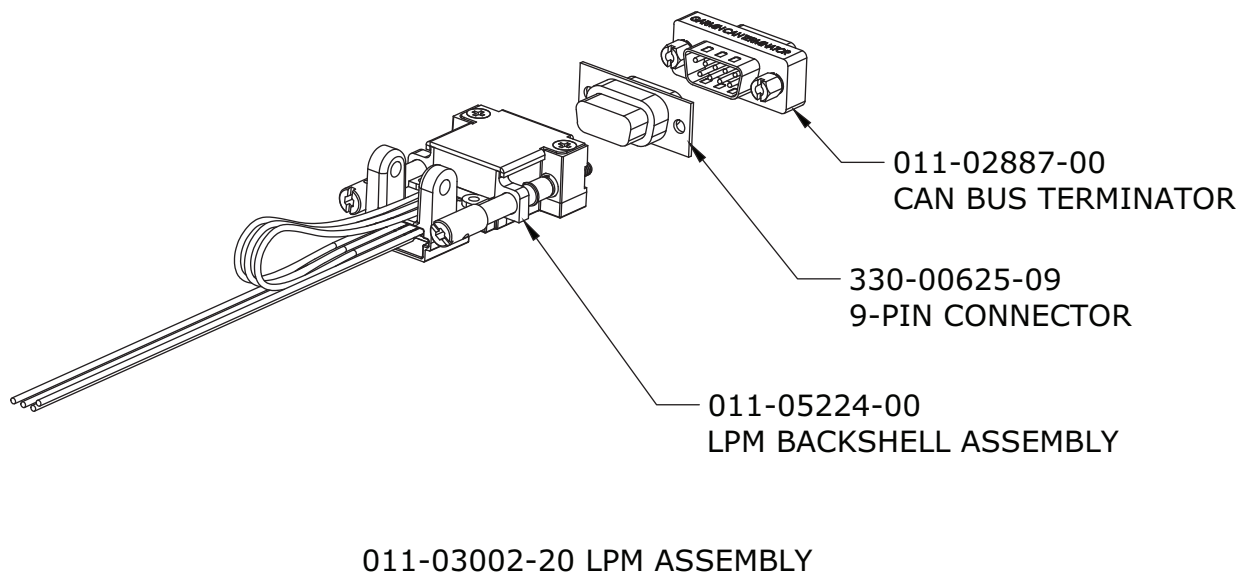

Figure 3-8 LPM Installation Drawing

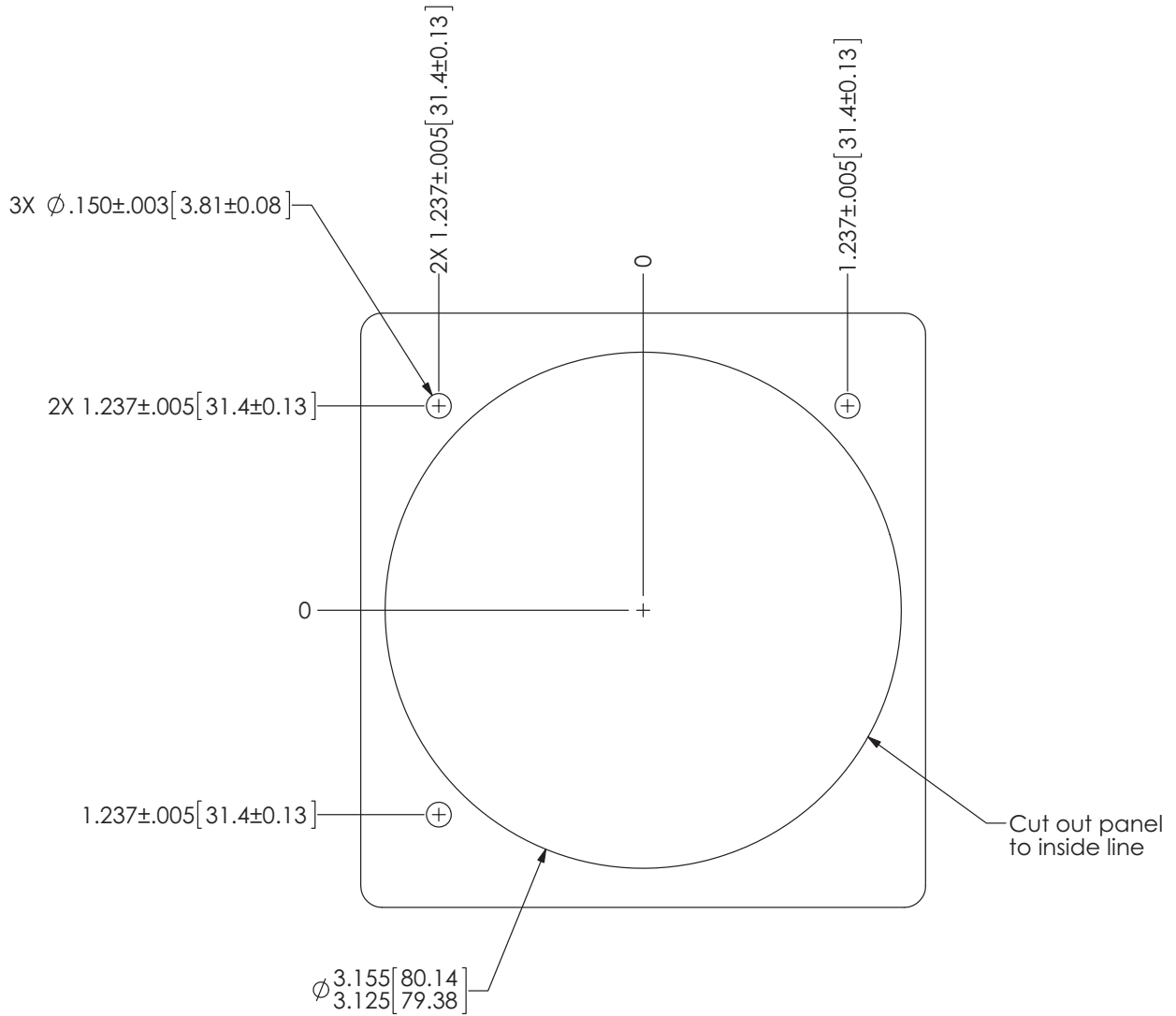
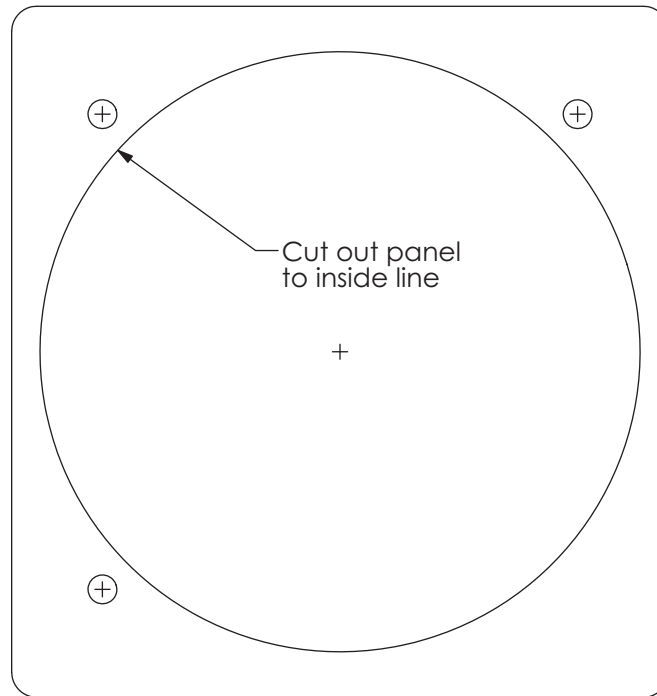

Figure 3-9 G5 Panel Cutout Measurements (Not to Scale)



IMPORTANT!

Ensure the Page Scaling setting is set to NONE when printing this page. Verify dimensions of printed template are accurate before cutting panel.

For mounting holes, drill out with #25 drill bit and use Garmin mounting rack P/N 115-02251-03.

For panel cutout, drill out with a 3.125" diameter bimetal hole saw.

The outline in this drawing is identical to the outline of the actual bezel.

Figure 3-10 G5 Panel Cutout Drawing (Template)

4 GPS ANTENNA INSTALLATION

This section contains general information as well as installation information for GPS antennas. Garmin recommends the antennas shown in [Table 4-2](#). However, any equivalent antenna that meets the specifications listed in [Table 4-3](#) will work with the G5.

The G5 can receive GPS position information using the unit's internal antenna or by connecting an external antenna. It is recommended to verify the ability of the G5 to receive GPS information from the unit's internal antenna as GPS reception quality is dependent upon the installation (see [Section 8.4.13.1](#) GPS Reception). The G5 will share GPS information with any connected GDU™ 37X/4XX.

The G5 can additionally receive GPS position information from a GPS 20A or GDU 37X/4XX. A minimum of one GPS antenna is required for G5 installations receiving GPS information from another LRU. Additional GPS antennas may be used for redundancy, but are not required.

A GPS 20A (and connected GPS/WAAS antenna) can be used as the sole GPS source for a G5 system, however it is recommended to also install a GPS antenna on a G5 or GDU 37X/4XX for redundancy. If the G5's GPS receiver is not used in a particular installation, it may be disabled in configuration mode (see [Section 8.4.13](#)).

4.1 Non-Garmin Antennas

Table 4-1 lists non-Garmin antennas currently supported by the G5. For non-Garmin antennas, follow the manufacturer's installation instructions. It is the installer's responsibility to ensure the chosen antenna meets FAA standards according to the specific installation.

Table 4-1 Supported Non-Garmin Antennas

Model	Mount Style	Conn Type	Antenna Type	Mfr	Antenna Part Number	Garmin Order Number
Comant 2480-201 VHF/GPS*	Screw Mount, Teardrop Footprint	BNC/TNC*	VHF COM/ GPS	Comant	CI 2480-201	N/A

*The GPS antenna connector is TNC type. The VHF COM antenna connector is BNC type.

4.2 Garmin Antennas



NOTE

See the *G3X™/G3X Touch™ Installation Manual (190-01115-01)* for detailed GPS antenna installation information. All antenna mounting and unit installation recommendations applicable to the GDU37X/4XX also apply to the G5.



NOTE

It is the installer's responsibility to ensure the chosen antenna meets FAA standards according to the specific installation.

Table 4-2 Supported Garmin Antennas

Model	Part Number	Install Manual	Mounting Configuration
GA 26C (GPS)	011-00149-04	190-00082-00	Flange, Magnetic, or Suction Cup Mounts (in-cabin)
GA 35 (GPS/WAAS)	013-00235-0X	190-00848-00	Thru-Mount (tear drop form factor)
GA 36 (GPS/WAAS)	013-00244-0X	190-00848-00	Thru-Mount (ARINC 743 form factor)
GA 56 (GPS)	011-00134-00	190-00094-00	Stud Mount (tear drop form factor)
GA 57X (GPS/XM)	011-01032-10	190-00522-02	Thru-Mount (ARINC 743 form factor)

Table 4-3 GPS Antenna Minimum Requirements

Characteristic	Specification
Frequency Range	1565 to 1585 MHz
Gain	16 to 25 dB typical, 40 dB max
Noise Figure	Less than 4.00 dB
Nominal Output Impedance	50 Ω
Supply Voltage	4.5 to 6.5 VDC
Supply Current	up to 60 mA

5 G5 PINOUT

Use the information in this section (along with other applicable sections in this document) to construct the wiring required for the G5 installation.

Connector references used throughout this document use the prefixes "J" (Jack) and "P" (Plug). "J" refers to the connector on the LRU, and "P" refers to the connector on the wiring harness. "J" and "P" designate the connector only, regardless of the contact type (pin or socket).

5.1 J51 Connector

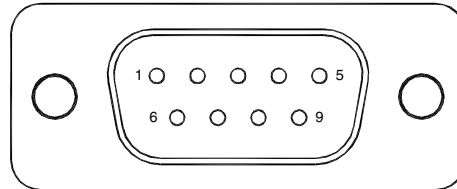

Figure 5-1 J51 Connector on the G5

Table 5-1 J51 Pin Descriptions

Pin	Pin Name	I/O
1	CAN-H	I/O
2	CAN-L	I/O
3	UNIT ID	In
4	RS-232 RX 1	In
5	RS-232 TX 1	Out
6	SIGNAL GROUND	--
7	AIRCRAFT POWER 1	In
8	AIRCRAFT POWER 2	In
9	POWER GROUND	--

5.1.1 Aircraft Power

The G5 can operate using power from one or both inputs (AIRCRAFT POWER 1 and AIRCRAFT POWER 2). The pins are internally connected using diodes to prevent current from flowing between the two power inputs. AIRCRAFT POWER 2 is for connecting to an alternate power source, such as on aircraft with two electrical buses.

5.1.2 RS-232

The G5 has one RS-232 channel that may be used to output and/or receive data from another device. Refer to [Section 8.4.13.5](#) for detailed information.

5.1.3 CAN Bus

The G5 CAN bus conforms to the BOSCH standard for Controller Area Network 2.0-B and ISO 11898. See [Section 2.2.2](#) for details. The CAN bus connection on the G5 can be used for the following:

- Connection to the G3X™ system
- G5/G5 interconnect (non-G3X system)
- G5/GSA 28 interconnect (non-G3X system)
- G5/GAD 29 interconnect (non-G3X system)
- G5/GMU 11 interconnect (non-G3X system)

5.1.4 Unit ID

The G5 detects its assigned unit type at startup by checking the UNIT ID pin. This pin can be strapped into the following configurations. A maximum of two G5 units may be used in a single installation.

Table 5-2 Unit ID Configurations

Unit ID	Comment
G5 #1	Leave pin 3 unconnected
G5 #2	Ground pin 3 to pin 6 or pin 9

6 CONNECTOR INSTALLATION INSTRUCTIONS

6.1 Shield Block Installation Parts

Table 6-1 and Table 6-2 list the parts needed to install a Shield Block. The item numbers in these tables correspond to the example drawing in [Figure 6-1](#). The parts listed in Table 6-1 are supplied in the G5 installation kit. The parts listed in Table 6-2 are to be provided by the installer as required.

Table 6-1 Garmin Supplied Shield Block Installation Parts for the G5

Item #	Description	GPN or MIL Spec
1	Backshell, Jackscrew, 9 pin	125-00171-00
6	Contact, Sckt, D-Sub, Crimp, Size 20, 20-24 AWG	336-00022-02
12	Clamp, Backshell, Jackscrew, 9 pin	115-01078-00
13	Screw, 4-40, 0.375"	211-60234-10
14	Cover, Backshell, Jackscrew, 9 pin	115-01079-00
15	Screw, 4-40, 0.187"	211-63234-06

Table 6-2 Installer Supplied Shield Block Installation Parts for the G5

Item #	Description	GPN or MIL Spec
2	Multiple Conductor Shielded Cable	Parts used depend on method chosen
3	Drain Wire Shield Termination (optional)	
4	Braid, Flat, 19-20 AWG Equivalent, Tin-plated Copper Strands, 36 AWG, Circular Mil Area 1000-1300	
5	Floating Shield Termination (optional)	
7	Ring terminal, #8, insulated, 18-22 AWG	
7	Ring terminal, #8, insulated, 14-16 AWG	MS25036-149
	Ring terminal, #8, insulated, 10-12 AWG	MS25036-153
		MS25036-156
8	Screw, 8-32, 0.312", PHP, Stainless	MS51957-42
	Screw, 8-32, 0.312", PHP, Cad-plated Steel	MS35206-242
9	Split Washer, #8, 0.045" Compressed Thickness, Stainless	MS35338-137
	Split Washer, #8, 0.045" Compressed Thickness, Cad-plated Steel	MS35338-42
10	Flat Washer, Stainless, #8, 0.032" Thick, 0.174" ID, 0.375" OD	NAS1149CN832R
	Flat washer, Cad-plated Steel, #8, 0.032" Thick, 0.174" ID, 0.375" OD	NAS1149FN832P
11	Silicone Fusion Tape	249-00114-00



NOTE

In Figure 6-1, "AR" denotes quantity "As Required" for the particular installation.

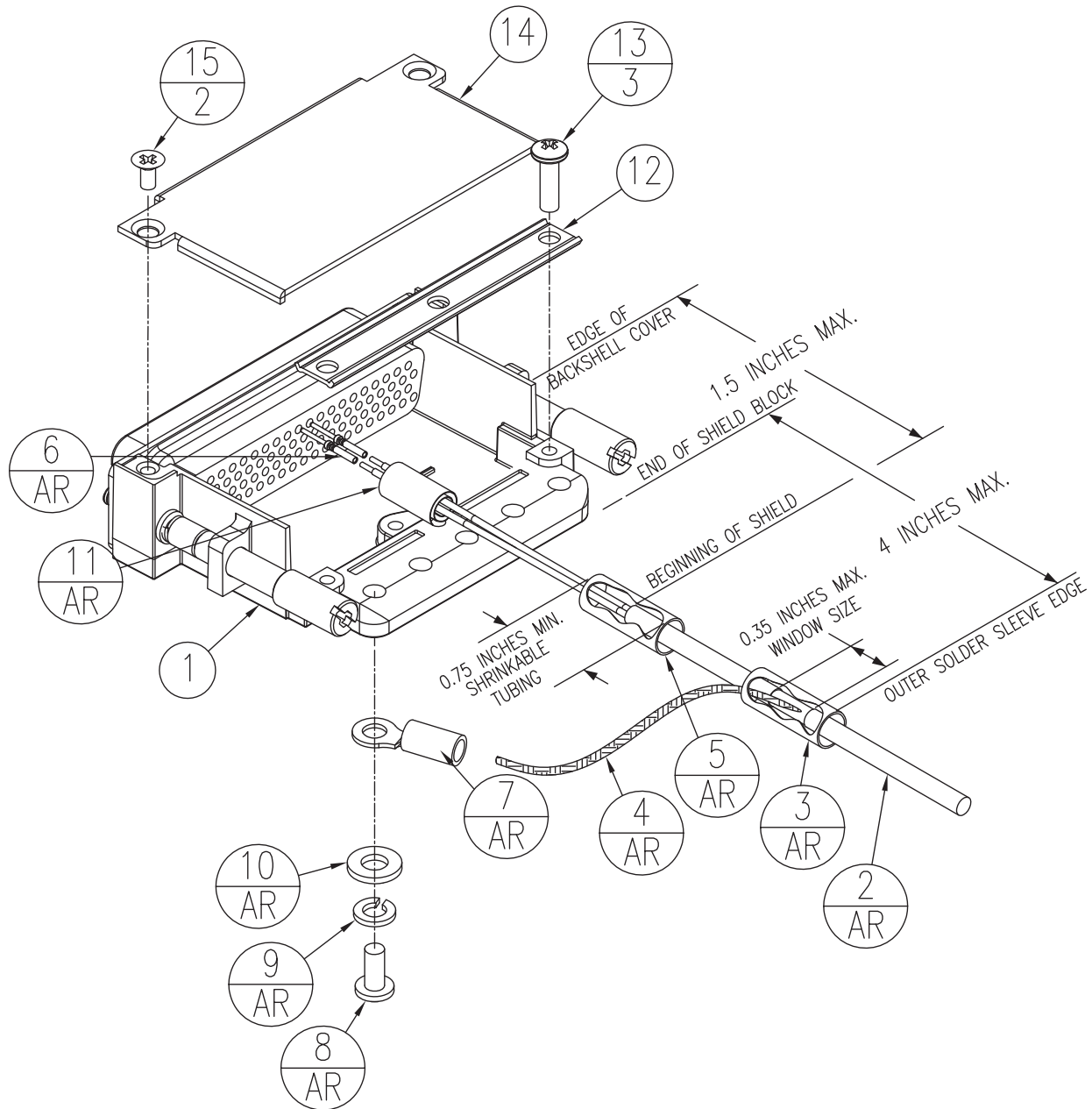

Figure 6-1 Example Shield Install onto a Jackscrew Backshell

6.2 Lightning Protection Module (LPM) Installation Parts

Table 6-3 and Table 6-4 list the parts needed to install a Shield Block. The item numbers in these tables correspond to the example drawing in [Figure 6-2](#). The parts listed in Table 6-3 are supplied in the G5 installation kit. The parts listed in Table 6-4 are to be provided by the installer as required.

Table 6-3 Garmin Supplied LPM Installation Parts for the G5

Item #	Description	GPN or MIL Spec
1	Lightning Protection Module assembly, Note 2	011-05224-00
6	Contact, Socket, MIL Crimp, Size 20, Note 1, 3	336-00022-02
12	Clamp, Backshell, Jackscrew, 9/15 Pin, Note 1, 3	115-01078-00
13	Screw, 4-40x.375, PHP, SS/P, w/Nylon, Note 1, 3	211-60234-10
14	Cover, Backshell, Jackscrew, 9/15 Pin, Note 1, 3	115-01079-00
15	Screw, 4-40x.187, FLHP100, SS/P, w/Nylon, Note 1,3	211-63234-06
16	Connector, Plug, D-Sub, MIL Crimp Socket, Note 1, 3	330-00625-09

Note 1 - Included in kit P/N 011-03002-00/10

Note 2 - Included in kit P/N 011-03002-20. This is only installed on the G5 connectors 1P51, 2P51. The GAD29/29B, GMU11, and GAD13 do not require this assembly.

Note 3 - Included in kit P/N 011-03002-20

Table 6-4 Installer Supplied LPM Installation Parts for the G5

Item #	Description	GPN or MIL Spec
2	Multiple Conductor Shielded Cable	
3	Shield Termination, Solder Style, Insulated, Heat-Shrinkable, Environment Resistant (X = size) Note 1	AS83519/1-X (SAE-AS83519)
4	Flat Braid, 1/16", Note 1	AA59569F36T0062
7	Terminal, Lug, Crimp Style, Copper, Insulated, Ring Tongue, Bell Mouthed, Type II, Class I	MS25036-149
8	Screw, PHP, 8-32 x 0.312", Cad-Plated Steel, or Screw, PHP, 8-32 x 0.312", Stainless	MS35206-242, or MS51957-42
9	Split Washer, #8 (0.045" compressed thickness), Cad-plated Steel, or Split Washer, #8 (0.045" compressed thickness), Stainless	MS35338-42, or MS35338-137
10	Flat washer, Cad-plated Steel, #8, 0.032" thick, 0.174" ID, 0.375" OD, or Flat Washer, Stainless, #8, 0.032" thick, 0.174" ID, 0.375" OD	NAS1149FN832P, or NAS1149CN832R
11	Insulation Tape, Electrical, Self-Adhering, Unsupported Silicone Rubber	A-A-59163 (MIL-I-46852C)

Note 1 - AS83519/1-X and braid are the preferred method for shield termination. Alternately, AS83519/2-X with pre-installed shield drain may be used.

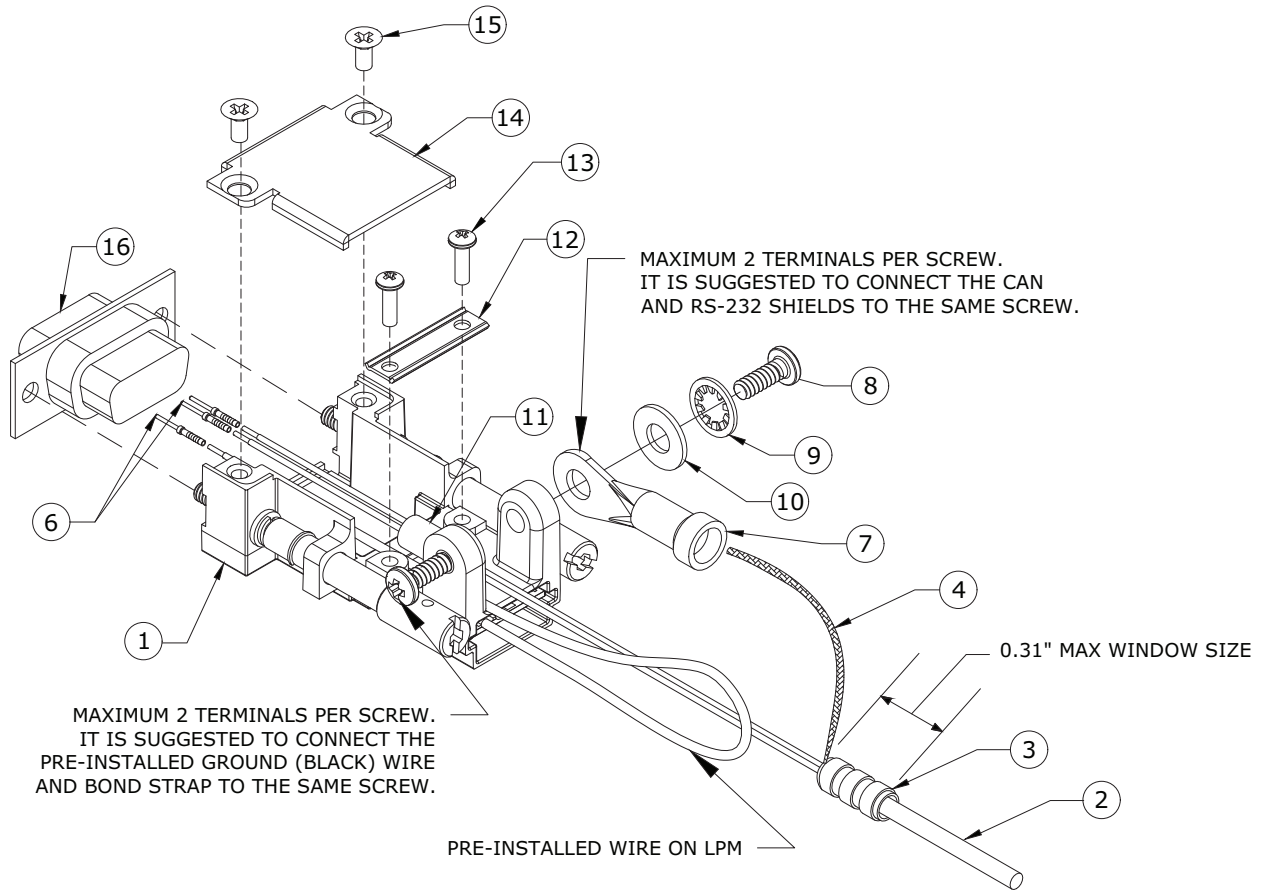

NOTES FOR CONNECTOR ASSEMBLY:

1. REFER TO LIGHTNING PROTECTION MODULE (LPM) WIRING INTERFACE INTERCONNECT FIGURE FOR SPECIFIC DISTANCES REQUIRED FOR ASSEMBLY.
2. A MAXIMUM OF FOUR TERMINALS ARE TO BE CONNECTED TO THE G5 BACKSHELL, TWO PER SCREW (ITEM 8 ABOVE).
 - 2.1. IT IS SUGGESTED THAT IF MULTIPLE DATA WIRE (CAN AND RS-232) SHIELDS ARE TO BE TERMINATED TO THE G5 BACKSHELL, THAT ALL SHIELDS ARE COMBINED INTO ONE TERMINAL.
 - 2.1.1. TWO SHIELD BRAIDS ARE TERMINATED USING A 14-16 GAUGE TERMINAL.
 - 2.1.1. THREE SHIELD BRAIDS ARE TERMINATED USING A 10-12 GAUGE TERMINAL.
3. THE PRE-INSTALLED GROUND WIRE (BLACK) CANNOT BE CONNECTED TO THE SAME SCREW AS THE CAN SHIELD TERMINATION SCREW.

Figure 6-2 Example LPM Harness and Connector Assembly

6.3 Shield Termination Technique – Method A.1 (Standard)

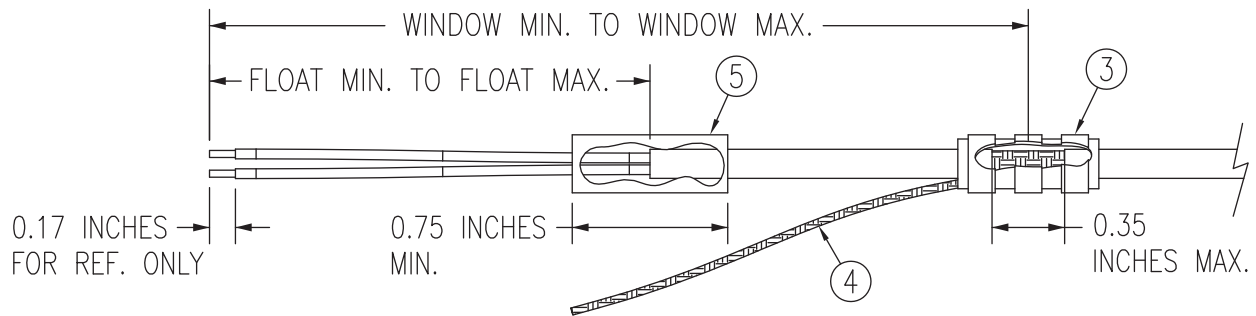

Figure 6-3 Shield Termination Technique Method A.1

Table 6-5 Shielded Cable Preparations for Garmin Connectors

Backshell Size	Number of Pins Std/HD	Float Min (inches)	Float Max (inches)	Ideal Float (inches)	Window Min (inches)	Window Max (inches)	Ideal Window (inches)
1	9/15	1.25	2.25	1.75	2.75	5.25	4.25
2	15/26	1.5	2.5	2.0	3.0	5.5	4.5
3	25/44	1.5	2.5	2.0	3.0	5.5	4.5
4	37/62	1.5	2.5	2.0	3.0	5.5	4.5
5	50/78	1.5	2.5	2.0	3.0	5.5	4.5

- At one end of a shielded cable (item 2, [Figure 6-1](#) or [Figure 6-2](#)) measure a distance between Window Min and Window Max (Table 6-5) and cut a window (with a max size of 0.35 inch) in the jacket to expose the shield. Use caution when cutting the jacket to avoid damaging the individual braids of the shield. When dealing with a densely populated connector with many cables, it may prove beneficial to stagger the windows throughout the Window Min to Window Max range. If staggering is not needed, the Ideal Window length is recommended. The following tools are recommended to make the window cut:
 - Coaxial Cable Stripper
 - Thermal Stripper
 - Sharp Razor Blade
- Connect a flat braid (item 4, Figure 6-3) to the shield exposed through the window of the prepared cable assembly from the preceding step. The flat braid should exit the front of the termination and towards the connector. The flat braid should not exit the rear of the termination and loop back towards the connector. Make the connection between the flat braid and the prepared cable assembly using an approved shield termination technique.



NOTE

FAA AC 43.13-1B Chapter 11, Section 8 (Wiring Installation Inspection Requirements) may be a helpful reference for termination techniques.

Preferred Method:

Slide a solder sleeve (item 3, [Figure 6-3](#)) onto the prepared cable assembly and connect the flat braid to the shield using a heat gun approved for use with solder sleeves. Using a solder sleeve with a pre-installed flat braid may ease the assembly. The chosen size of solder sleeve must accommodate both the number of conductors present in the cable and the flat braid.

Solder sleeves with pre-installed flat braid

The preferred solder sleeve is the Raychem S03 Series with a thermochromic temperature indicator (S03-02-R-9035-100, S03-03-R-9035-100, S03-04-R-9035-100). These solder sleeves come with a pre-installed braid and effectively take the place of items 3 and 4 in [Figure 6-3](#). Reference the Raychem installation procedure, RCPS 100-70, for detailed instructions. Raychem recommends the following heating tools:

- HL1802E
- AA-400 Super Heater
- CV-1981
- MiniRay
- IR-1759

Individual solder sleeves and flat braid

Solder Sleeves:

Reference the following MIL-SPECs for solder sleeves:

- M83519/1-1
- M83519/1-2
- M83519/1-3
- M83519/1-4
- M83519/1-5

Flat Braid:

Flat braids should conform to the ASTM B33 standard for tin-plated copper wire and be made up of 36 AWG strands to form an approximately 19-20 AWG equivalent flat braid. A circular mil area range of 1000 to 1300 is required. The number of individual strands in each braid bundle is not specified. Reference MIL-SPEC flat braid QQB575F36T062.



NOTE

Flat braid, as opposed to insulated wire, is specified in order to allow for a visual inspection of the conductor as required for continued airworthiness.

Secondary Method:

Solder a flat braid to the shield exposed through the window of the prepared cable assembly. Ensure a solid electrical connection through the use of acceptable soldering practices. Use care to avoid applying excessive heat that burns through the insulation of the center conductor(s) and shorts the shield to the signal wire(s). Slide a minimum of 0.75 inch of Teflon heat shrink tubing (item 3, [Figure 6-3](#)) onto the prepared wire assembly and shrink using a heat gun. The chosen size of heat shrink tubing must accommodate both the number of conductors present in the cable and the flat braid.

Teflon heat shrink tubing

Reference MIL-SPEC Teflon heat shrink tubing M23053/5-X-Y.

- At the same end of the shielded cable and ahead of the previous shield termination, strip back the jacket and shield from the end of the shielded cable to a distance between Float Min and Float Max (Table 6-5) to expose the insulated center conductor(s). If possible, the Ideal Float length is recommended.

Preferred Method:

Cut the jacket and the shield off at the same point so that no shield is exposed. Slide a minimum of 0.75 inch of Teflon heat shrink tubing (item 5, Figure 6-3) onto the cable and use a heat gun to shrink the tubing. The chosen size of heat shrink tubing must accommodate the number of conductors present in the cable.

Secondary Method:

Leave a maximum 0.35 inch of shield extending past the jacket. Fold this section of shield back over the jacket. Slide a solder sleeve (item 5, Figure 6-3) over the end of the cable and use a heat gun approved for solder sleeves to secure the connection. The chosen size of solder sleeve must accommodate the number of conductors present in the cable.

- Strip back approximately 0.17 inch of insulation from each wire of the shielded cable (item 2, Figure 6-4) and crimp a contact (item 6, Figure 6-4) to each conductor. It is the responsibility of the installer to find the proper length of insulation to be removed. The wire must be visible in the inspection hole after crimping and the insulation must be 1/64 – 1/32 of an inch from the end of the contact as shown in Figure 6-4.

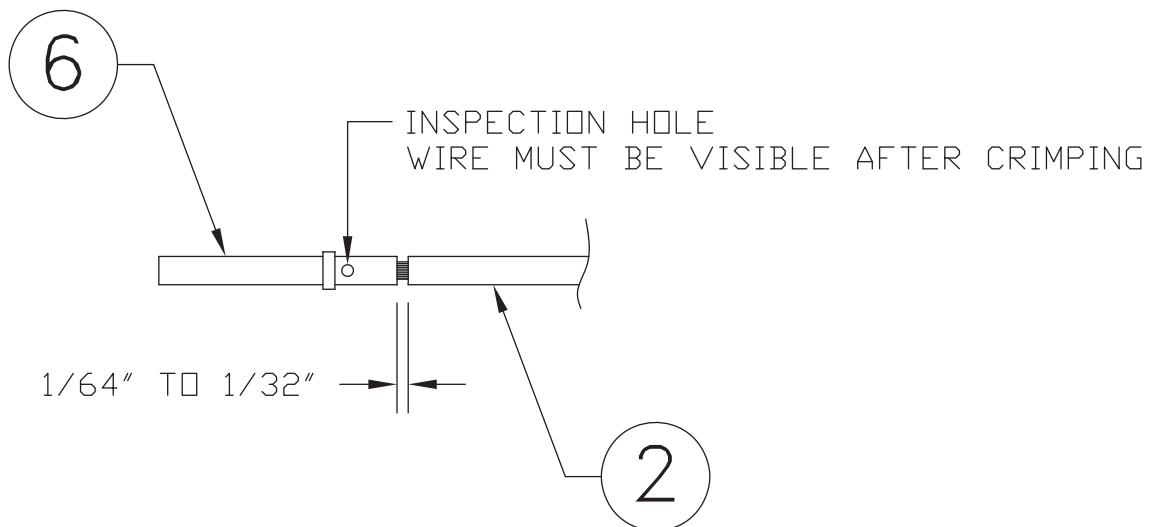

Figure 6-4 Insulation/Contact Clearance

5. Insert the newly crimped pins and wires into the appropriate connector housing location as specified by the installation wiring diagrams.
6. Cut the flat braid to a length that, with the addition of a ring terminal, will reach one of the tapped holes of the Jackscrew Backshell (item 1, [Figure 6-1](#) or [Figure 6-2](#)). An appropriate amount of excess length without looping should be given to the flat braid to allow it to freely move with the wire bundle.



NOTE

The window splice should be positioned so the flat braid is no longer than 4 inches.

7. Guidelines for terminating the flat braid with an insulated ring terminal:
 - Each tapped hole on the Jackscrew Backshell may accommodate a maximum of two ring terminals.
 - Each ring terminal may accommodate a maximum of three flat braids. However, it is recommended to terminate a maximum of two flat braids per ring terminal.
 - A #8, insulated, 18-22 AWG ring terminal is recommended for terminating a single flat braid (reference MIL-SPEC MS25036-149).
 - A #8, insulated, 14-16 AWG ring terminal is recommended for terminating two flat braids (reference MIL-SPEC MS25036-153).
 - A #8, insulated, 10-12 AWG ring terminal is recommended for terminating three flat braids (reference MIL-SPEC MS25036-156).
8. Repeat the preceding steps as necessary for the remaining shielded cables.
9. Terminate the ring terminal to the Jackscrew Backshell by placing the following items on the screw (item 8, [Figure 6-1](#) or [Figure 6-2](#)) in order: split washer (item 9, [Figure 6-1](#) or [Figure 6-2](#)), flat washer (item 10, [Figure 6-1](#) or [Figure 6-2](#)), ring terminal (item 7, [Figure 6-1](#) or [Figure 6-2](#)). This assembly can then be screwed into the tapped holes on the Jackscrew Backshell.
10. It is recommended to wrap the cable bundle with silicone fusion tape (item 11, [Figure 6-1](#) or [Figure 6-2](#)) at the point where the backshell clamp (item 12, [Figure 6-1](#) or [Figure 6-2](#)) and backshell housing will contact the cable bundle.



NOTE

Use of silicone fusion tape is at the discretion of the installer.

11. Place the smooth side of the backshell clamp across the cable bundle and secure using the provided screws (item 13, [Figure 6-1](#) or [Figure 6-2](#)).



WARNING

Placing the grooved side of the backshell clamp across the cable bundle may cause damage to the wires.

12. Attach the backshell cover (item 14, [Figure 6-1](#) or [Figure 6-2](#)) to the backshell using the provided screws (item 15, [Figure 6-1](#) or [Figure 6-2](#)).

6.4 Shield Termination Technique – Method A.2 (Daisy Chain)

In rare situations where more flat braids need to be terminated for a connector than three per ring terminal it is allowable to daisy chain a maximum of two shields together before terminating to the ring terminal (Figure 6-5). All other restrictions and instructions for the shield termination set forth in Method A.1 are still applicable.



NOTE

The maximum length of the combined braids should be 4 inches.

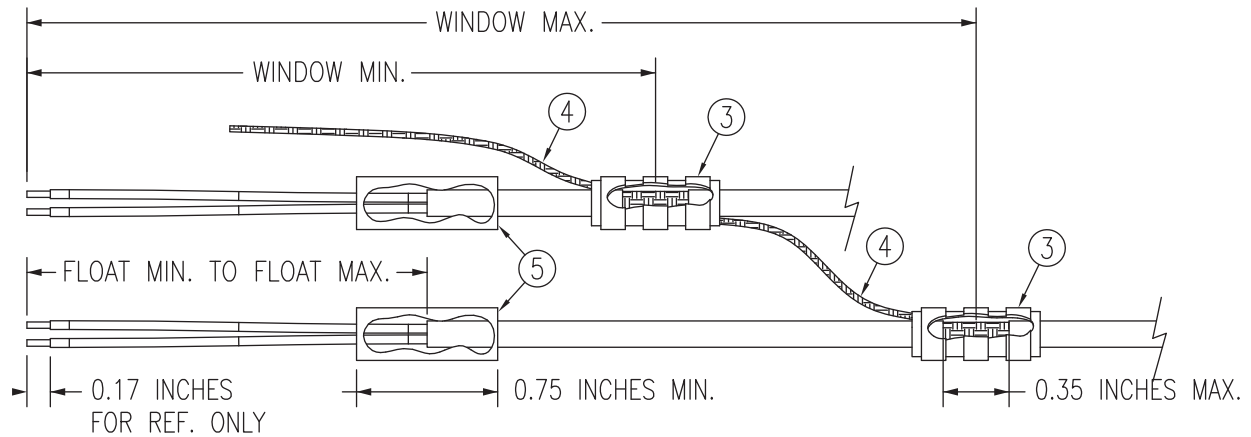

Figure 6-5 Shield Termination Technique Method A.2

6.5 Shield Termination Technique – Method B.1 (Quick Term)

If desired, the drain wire termination (item 3, [Figure 6-1](#) or [Figure 6-2](#)) and the floating shield termination (item 5, [Figure 6-1](#)) can be effectively combined into a “Quick Term”. This method eliminates the float in the cable insulation and moves the placement of the window described in Method A.1. This technique is depicted in Figure 6-6.



NOTE

The original purpose for separating the shield drain termination from the float termination in Method A.1 was to allow for a variety of lengths for the drain wires so the shield drain terminations would not all bunch up in the harness and to eliminate loops in the drain wires. If Method B.1 is used, care must be taken to ensure that all drain shield terminations can still be inspected. Garmin recommends using Method A.1 on connectors which require a large number of shield drain terminations, as this will allow these terminations to be dispersed across a larger area.

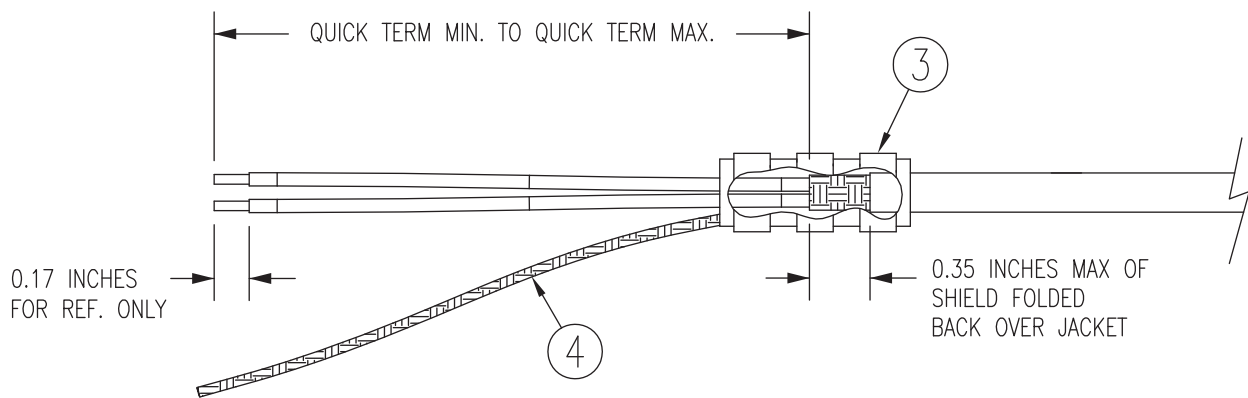

Figure 6-6 Shield Termination Technique Method B.1

1. At one end of a shielded cable (item 2, [Figure 6-1](#) or [Figure 6-2](#)) measure a distance between Window Min and Window Max ([Table 6-6](#)) and cut a window (with a max size of 0.35 inch) in the jacket to expose the shield. Use caution when cutting the jacket to avoid damaging the individual braids of the shield. When dealing with a densely populated connector with many cables, it may prove beneficial to stagger the windows throughout the Window Min to Window Max range. If staggering is not needed, the Ideal Window length is recommended. The following tools are recommended to make the window cut:
 - Coaxial Cable Stripper
 - Thermal Stripper
 - Sharp Razor Blade

Table 6-6 Shielded Cable Preparations – (Quick Term)

Backshell Size	Number of Pins Std/HD	Quick Term Min (inches)	Quick Term Max (inches)	Quick Term Float (inches)
1	9/15	1.25	2.25	1.75
2	15/26	1.5	2.5	2.0
3	25/44	1.5	2.5	2.0
4	37/62	1.5	2.5	2.0
5	50/78	1.5	2.5	2.0

2. Strip back the jacket from the end of the shielded cable to a distance between Quick Term Min and Quick Term Max ([Table 6-5](#)) to expose the shield. Next trim the shield so that a maximum of 0.35 inch of shield extends beyond the jacket. Fold this section of shield back over the jacket.
3. Connect a flat braid (item 4, [Figure 6-6](#)) to the folded back shield of the prepared cable assembly. The flat braid should exit the front of the termination and towards the connector. The flat braid should not exit the rear of the termination and loop back towards the connector. Make the connection between the flat braid and the prepared cable assembly using an approved shield termination technique.



NOTE

FAA AC 43.13-1B Chapter 11, Section 8 (Wiring Installation Inspection Requirements) may be a helpful reference for termination techniques.

Preferred Method:

Slide a solder sleeve (item 3, [Figure 6-6](#)) onto the prepared cable assembly and connect the flat braid to the shield using a heat gun approved for use with solder sleeves. Using a solder sleeve with a pre-installed flat braid may ease the assembly. The chosen size of solder sleeve must accommodate both the number of conductors present in the cable and the flat braid.

Secondary Method:

Solder a flat braid to the folded back shield of the prepared cable assembly. Ensure a solid electrical connection through the use of acceptable soldering practices. Use care to avoid applying excessive heat that burns through the insulation of the center conductor(s) and shorts the shield to the signal wire(s). Slide a minimum of 0.75 inch of Teflon heat shrink tubing (item 3, [Figure 6-6](#)) onto the prepared wire assembly and shrink using a heat gun. The chosen size of heat shrink tubing must accommodate both the number of conductors present in the cable and the flat braid.

Teflon heat shrink tubing

Reference MIL-SPEC Teflon heat shrink tubing M23053/5-X-Y.

4. Insert the newly crimped pins and wires into the appropriate connector housing location as specified by the installation wiring diagrams.

5. Cut the flat braid to a length that, with the addition of a ring terminal, will reach one of the tapped holes of the Jackscrew Backshell (item 1, [Figure 6-1](#) or [Figure 6-2](#)). An appropriate amount of excess length without looping should be given to the flat braid to allow it to freely move with the wire bundle.

**NOTE**

The window splice should be positioned so the flat braid is no longer than 4 inches.

6. Guidelines for terminating the flat braid with an insulated ring terminal:
 - Each tapped hole on the Jackscrew Backshell may accommodate a maximum of two ring terminals.
 - Each ring terminal may accommodate a maximum of three flat braids. However, it is recommended to terminate a maximum of two flat braids per ring terminal.
 - A #8, insulated, 18-22 AWG ring terminal is recommended for terminating a single flat braid (reference MIL-SPEC MS25036-149).
 - A #8, insulated, 14-16 AWG ring terminal is recommended for terminating two flat braids (reference MIL-SPEC MS25036-153).
 - A #8, insulated, 10-12 AWG ring terminal is recommended for terminating three flat braids (reference MIL-SPEC MS25036-156).
7. Repeat the preceding steps as necessary for the remaining shielded cables.
8. Terminate the ring terminal to the Jackscrew Backshell by placing the following items on the screw (item 8, [Figure 6-1](#) or [Figure 6-2](#)) in order: split washer (item 9, [Figure 6-1](#) or [Figure 6-2](#)), flat washer (item 10, [Figure 6-1](#) or [Figure 6-2](#)), ring terminal (item 7, [Figure 6-1](#) or [Figure 6-2](#)). This assembly can then be screwed into the tapped holes on the Jackscrew Backshell.
9. It is recommended to wrap the cable bundle with silicone fusion tape (item 11, [Figure 6-1](#) or [Figure 6-2](#)) at the point where the backshell clamp (item 12, [Figure 6-1](#) or [Figure 6-2](#)) and backshell housing will contact the cable bundle.

**NOTE**

Use of silicone fusion tape is at the discretion of the installer.

10. Place the smooth side of the backshell clamp across the cable bundle and secure using the provided screws (item 13, [Figure 6-1](#) or [Figure 6-2](#)).

**WARNING**

Warning: Placing the grooved side of the backshell clamp across the cable bundle may cause damage to the wires.

11. Attach the backshell cover (item 14, [Figure 6-1](#) or [Figure 6-2](#)) to the backshell using the provided screws (item 15, [Figure 6-1](#) or [Figure 6-2](#)).

6.6 Shield Termination Technique – Method B.2 (Daisy Chain-Quick Term)

In rare situations where more flat braids need to be terminated for a connector than three per ring terminal it is allowable to daisy chain a maximum of two shields together before terminating to the ring terminal (Figure 6-7). All other restrictions and instructions for the shield termination set forth in Method B.1 are still applicable.



NOTE

The maximum length of the combined braids should be 4 inches.

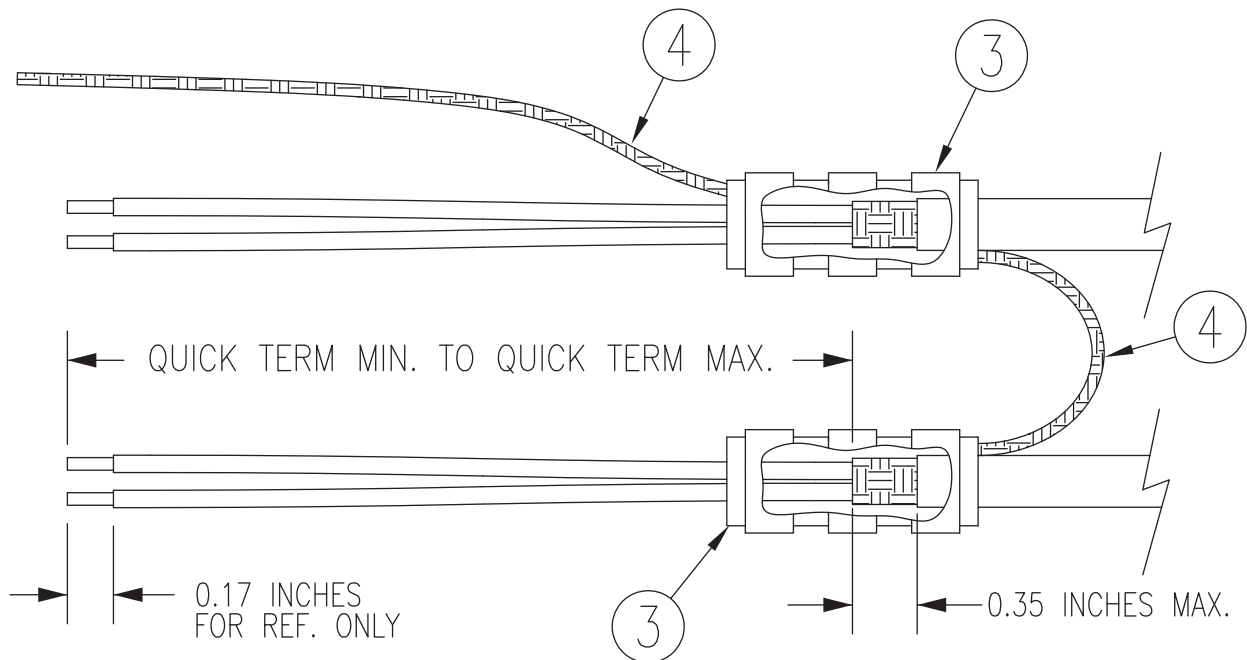

Figure 6-7 Shield Termination Technique Method B.2

6.7 Daisy Chain between Methods A.1 and B.1

In rare situations where more flat braids need to be terminated for a connector than three per ring terminal and a mixture of Methods A.1 and B.1 have been used, it is allowable to daisy chain a maximum of two shields together between a Method A.1 and B.1 termination before terminating to the ring terminal (Figure 6-8). All other restrictions and instructions for the shield termination set forth in Method A.1 and B.1 are still applicable.



NOTE

The maximum length of the combined braids should be 4 inches.

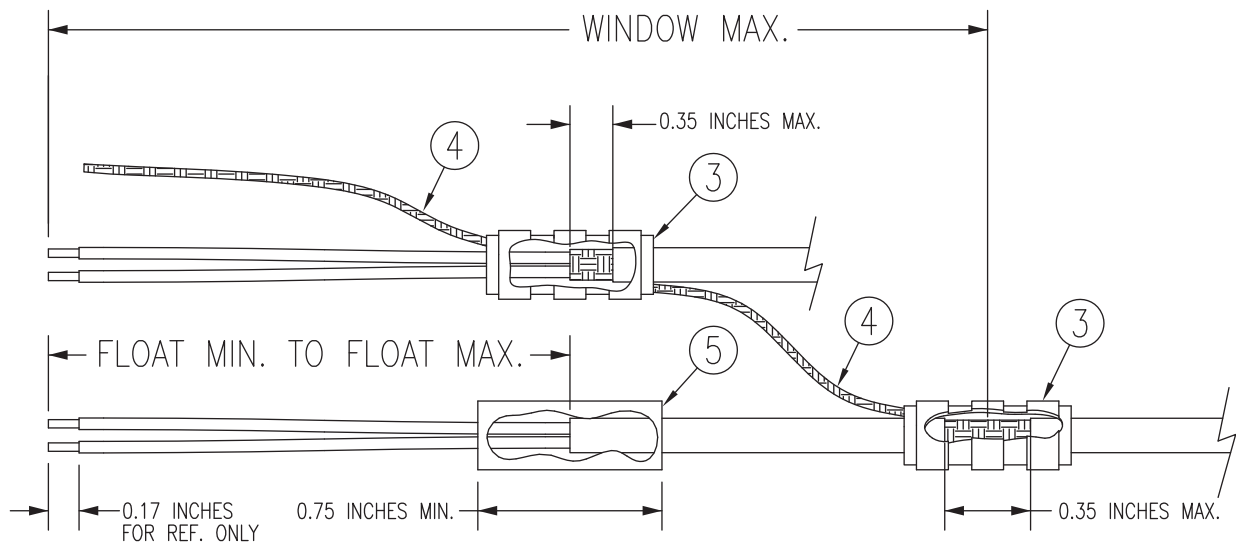

Figure 6-8 Shield Termination Technique Methods A.1 and B.1

6.8 Unit ID (Strapping)

The Unit ID Program Pin on the G5 provides a ground reference used by the hardware as a means of configuring the unit for system identification. When installing two G5 units, the second unit must have its UNIT ID pin (J51 pin 3) connected to ground. For the first G5, this pin should be left unconnected. The following instructions illustrate how this ground strapping should be accomplished with the Jackscrew Backshell.

1. Cut a 4-inch length of 22 AWG insulated wire.



WARNING

Flat braid is not permitted for this purpose. Use only insulated wire to avoid inadvertent ground issues that can occur when using exposed conductors.

2. Strip back approximately 0.17 inch of insulation and crimp a contact to the 4-inch length of wire. It is the responsibility of the installer to find the proper length of insulation to be removed. The wire must be visible in the inspection hole after crimping and the insulation must be 1/64 – 1/32 of an inch from the end of the contact as shown in [Figure 6-4](#).
3. Insert the crimped pin and wire into the appropriate connector housing location as specified by the installation wiring diagrams.
4. At the opposite end of the wire, strip back 0.2 inch of insulation.
5. Terminate this end of the wire in conjunction with the flat braids of the shield terminations. If this ground strap is the only termination, use a #8, insulated, 18-22 AWG ring terminal for the termination (reference MIL-SPEC MS25036-149).

6.9 Splicing Signal Wires

Figure 6-9 shows an example two wire splice. Note the splice must be made within 3 inches of the Shield Block. A signal wire should be spliced into a maximum of three wires. This wire splicing technique can be used with all the shield termination methods outlined in the previous sections. The following wire splice parts are recommended:

- Raychem D-436-36/37/38
- MIL-SPEC MIL-S-81824/1



WARNING

Keep the splice out of the backshell for pin extraction, and outside of the strain relief to avoid preloading.

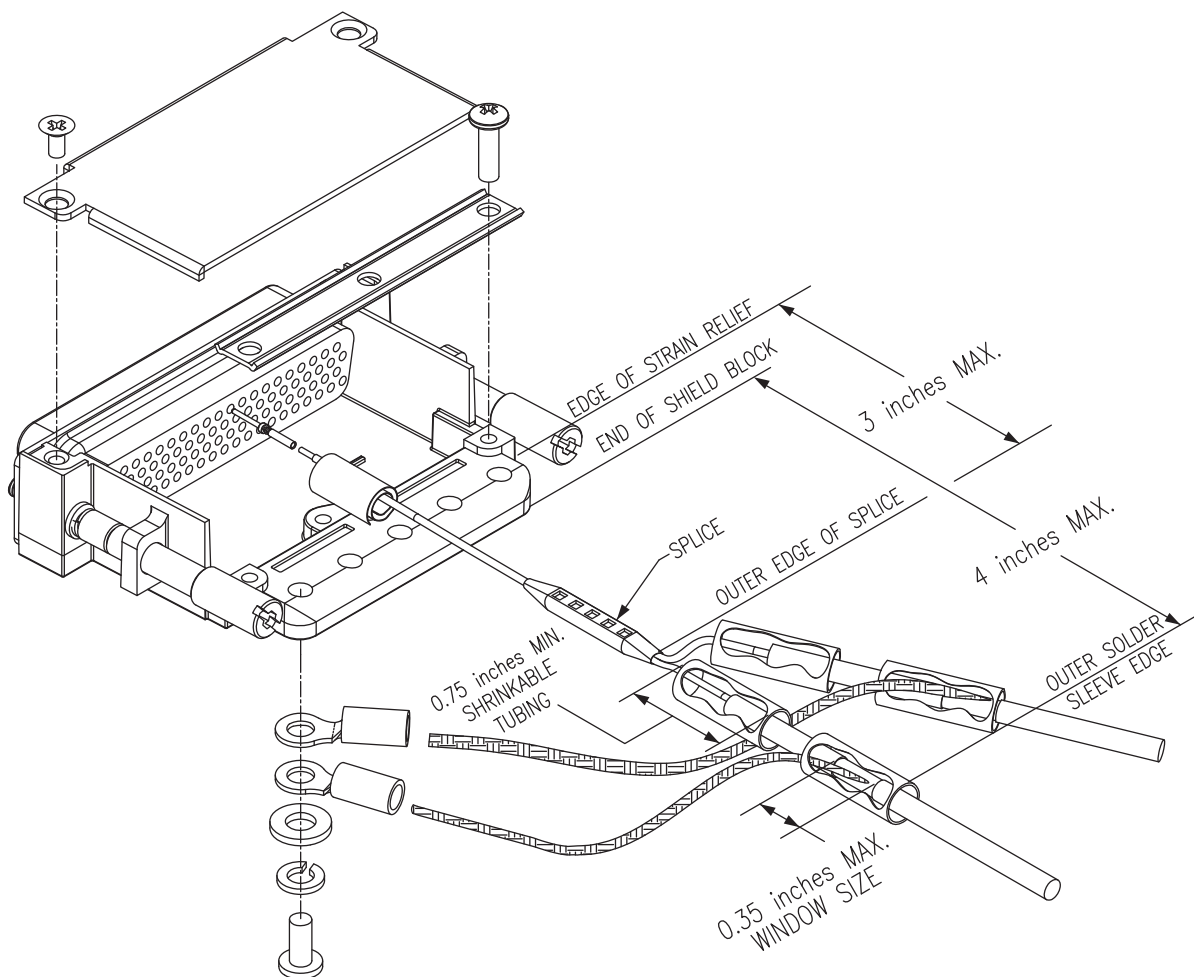

Figure 6-9 D-Sub Spliced Signal Wire Example

7 INTERCONNECT DRAWINGS

FIGURE	PAGE
G5 Interconnect Notes	7-2
G5 Standalone Interconnect Drawing.....	7-3
G5 Lightning Protection Module (LPM) Interconnect Drawing.....	7-4
G5 Used as an Altitude Encoder Interconnect Drawing.....	7-5
G5 CAN Bus Interconnect Drawing.....	7-6
G5 to Serial Navigator Interconnect Drawing.....	7-7
Dual G5 to GNC® 255/SL30 Interconnect Drawing	7-8
G5 Autopilot System with GMC 305/307 Interconnect Drawing.....	7-9
G5 Autopilot System with GMC 507 Interconnect Drawing	7-10
G5/GAD 13 to GMU 11 Interconnect Drawing	7-11
G5/GAD 29 to aera®/GNC 255 Dual Nav Interconnect Drawing.....	7-12
G5/GAD 29 to aera/GNX™ 375 Dual Nav Interconnect Drawing.....	7-13
G5/GAD 29 to aera/GTN™ 6XX/7XX Dual Nav Interconnect Drawing	7-14
G5/GAD 29 to GNC 255/GTN 6XX/7XX Dual Nav Interconnect Drawing.....	7-15
G5/GAD 29 to GNC 300XL/GPS 155XL Dual Nav Interconnect Drawing	7-16
G5/GAD 29 to GNS™ 4XX/5XX Interconnect Drawing.....	7-17
G5/GAD 29 to GNS 480 Interconnect Drawing	7-18
G5/GAD 29 to GNX 375 Interconnect Drawing.....	7-19
G5/GAD 29 to GNX 375/GNC 255 Interconnect Drawing	7-20
G5/GAD 29 to GNX 375/SL 30 Interconnect Drawing	7-21
G5/GAD 29 to GNC 355 Interconnect Drawing.....	7-22
G5/GAD 29 to GPS 175 Interconnect Drawing	7-23
G5/GAD 29 to GTN 6XX/7XX Interconnect Drawing.....	7-24
G5/GAD 29 to GTN 6XX/7XX Dual Nav Interconnect Drawing	7-25

NOTES:

1. UNLESS OTHERWISE NOTED, ALL STRANDED WIRE MUST CONFORM TO MIL-W-22759/16 OR EQUIVALENT.
2. UNLESS OTHERWISE NOTED, ALL SHIELDED WIRE MUST CONFORM TO MIL-C-27500 OR EQUIVALENT.
3. UNLESS OTHERWISE NOTED, ALL WIRES ARE 22 GAUGE MINIMUM.
4. SYMBOL DESIGNATIONS

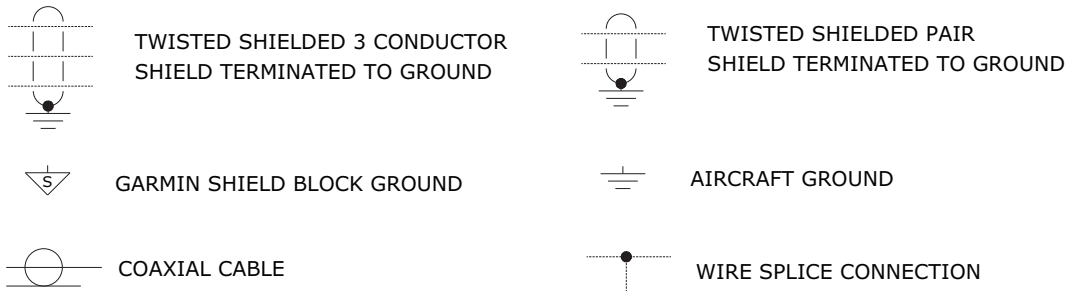

5. UNLESS OTHERWISE NOTED, ALL SHIELD GROUNDS MUST BE MADE TO THE RESPECTIVE UNIT BACKSHELLS. ALL OTHER GROUNDS SHOULD BE TERMINATED TO AIRCRAFT GROUND AS CLOSE TO THE RESPECTIVE UNIT AS POSSIBLE.
6. REFER TO THE G3X INSTALLATION MANUAL (190-01115-01) FOR INSTALLATION AND WIRING GUIDANCE FOR ALL DEVICES EXCEPT THE G5 AND THE GNC/GNS/GTN UNITS.
7. A GAD 29 A429 INTERFACE CONNECTED TO THE CAN BUS IS REQUIRED WHEN A GNS 4XX(W)/5XX(W) (INCLUDING GNS 480) OR A GTN 6XX/7XX NAVIGATOR IS USED.

Figure 7-1 G5 Interconnect Notes

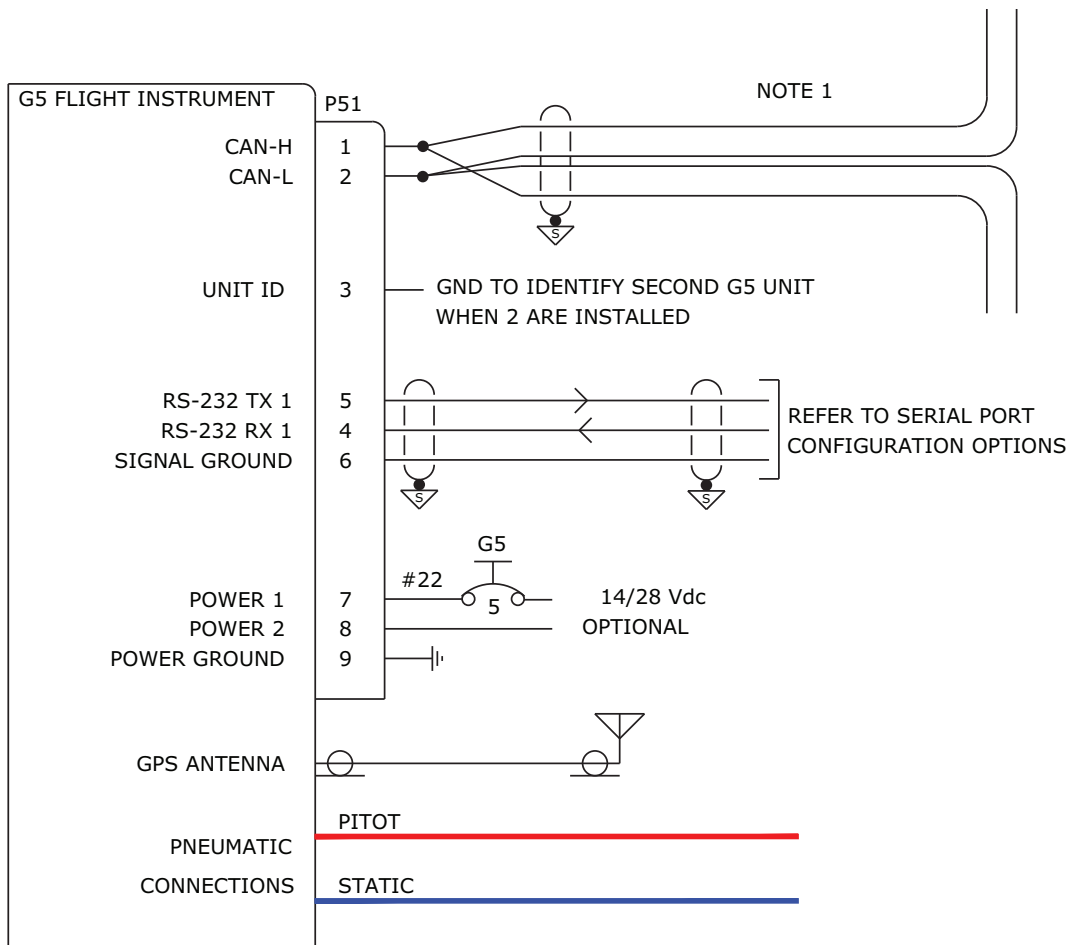

NOTES:

1. CAN BUS IS USED WHEN INSTALLED IN A G3X SYSTEM OR WHEN INSTALLED WITH GSA 28 SERVOS AND/OR GAD 29 A429 INTERFACE

CONFIGURATION GUIDANCE

1. G3X

- A. NO CONFIGURATION REQUIRED

2. G5 (WHEN NOT USED WITH THE G3X SYSTEM)

- A. ON THE G5 CONFIG MODE DEVICE INFORMATION CONFIGURATION PAGE:

- SET THE INSTALLATION TYPE TO "STANDALONE INSTRUMENT"

Figure 7-2 G5 Standalone Interconnect Drawing

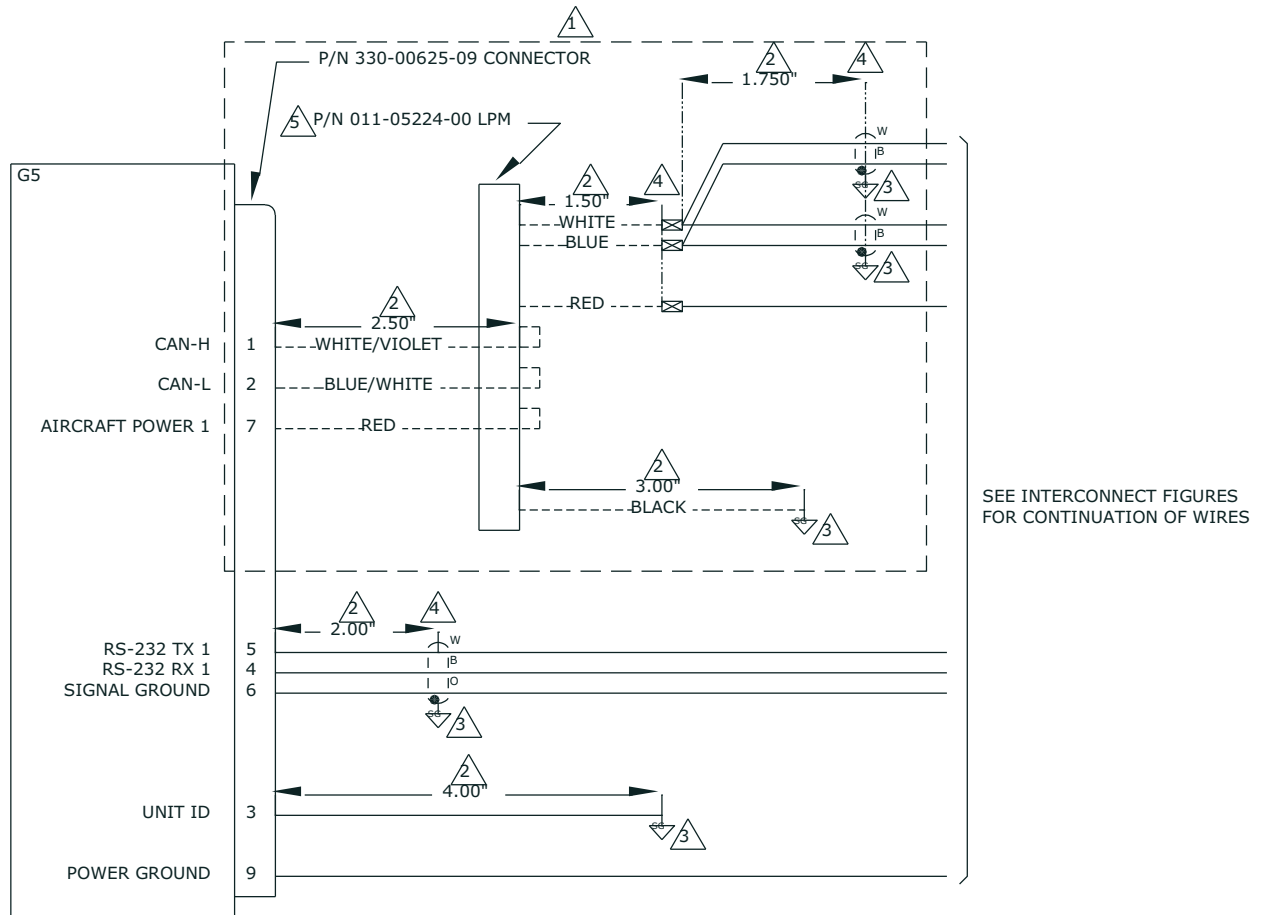

SEE INTERCONNECT FIGURES FOR CONTINUATION OF WIRES

- 1 DASHED WIRES SHOWN ARE PRE-INSTALLED WIRES IN THE LPM ASSEMBLY 011-05224-00.
- 2 DIMENSIONS SHOWN ARE MAXIMUM LENGTHS.
- 3 SHIELD GROUNDS/UNIT ID WIRE ARE GROUNDED TO THE BACKSHELL OF THE LPM ASSEMBLY 011-05224-00.
- 4 DIMENSIONS SHOWN FOR SHIELD GROUNDS ARE MEASURED FROM CONNECTOR/SPLICE END TO BEGINNING OF SOLDER SLEEVE.
- 5 REFER TO SECTION 4 FOR DETAILED CONNECTOR BUILDUP USING THE LPM.

Figure 7-3 G5 Lightning Protection Module Interconnect Drawing

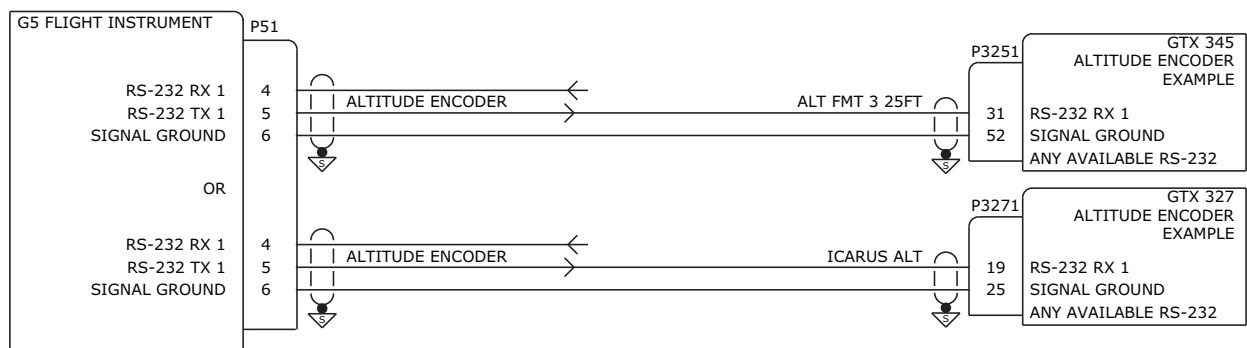

Figure 7-4 G5 Used as an Altitude Encoder Interconnect Drawing

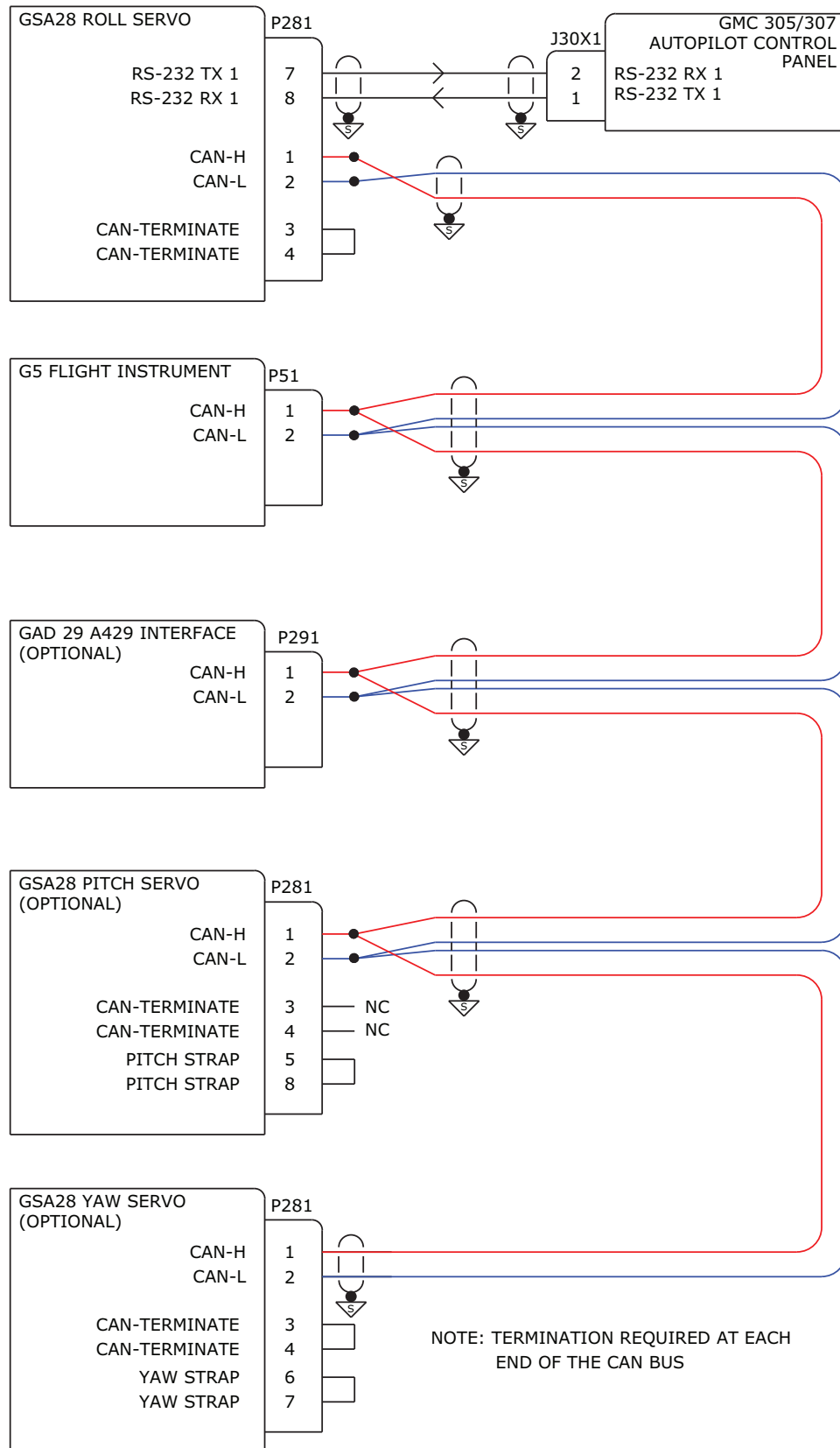
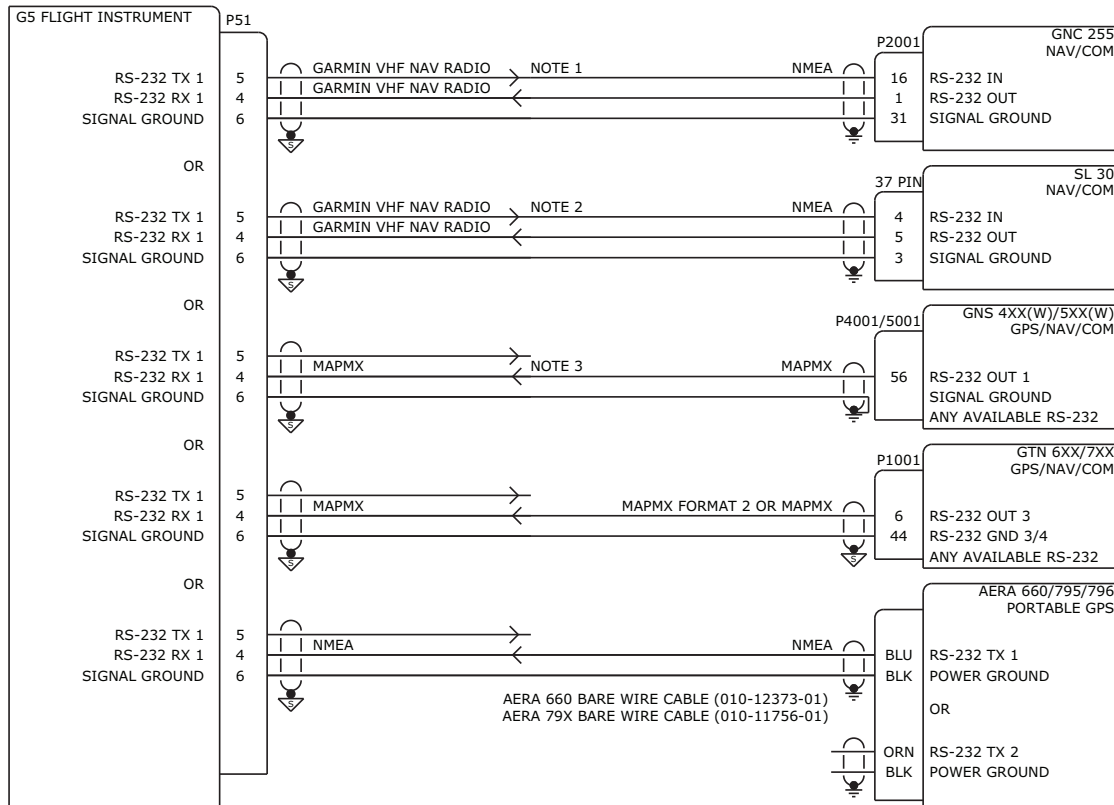

Figure 7-5 G5 CAN Bus Interconnect Drawing



NOTES

1. **G5 TX CONFIGURED FOR NMEA (GNC255) WHEN MECHANICAL CDI IS IN USE**
2. **G5 TX NOT USED FOR SL30 WHEN MECHANICAL CDI IS IN USE**
3. **USE "MAPMX" FOR GNS WAAS UNITS AND "AVIATION" FOR NON-WAAS UNITS ON BOTH GNS AND G5**

CONFIGURATION GUIDANCE

SL30 OR GNC255 WITHOUT MECHANICAL CDI INSTRUMENT

(RS-232 CONNECTION TO G5 IS BI-DIRECTIONAL. OBS COURSE SELECTION IS MADE ON THE G5)

- A. G5 CONFIGURATION
 - SET RS-232 INPUT AND OUTPUT FORMAT TO "GARMIN VHF NAV RADIO"
- B. NAV RADIO CONFIGURATION
 - SET GNC255 RS-232 FORMAT TO "NMEA" (NO SETTING FOR SL 30)
 - SET SL30/GNC255 INDICATOR TYPE TO "SERIAL"

SL30 OR GNC255 WITH MECHANICAL CDI INSTRUMENT

(OBS COURSE SELECTION IS MADE USING OBS KNOB ON MECHANICAL CDI)

- A. G5 CONFIGURATION
 - SET RS-232 INPUT FORMAT TO "GARMIN VHF NAV RADIO"
 - SET RS-232 OUTPUT FORMAT TO "NMEA" (OPTIONAL FOR GNC255, NO SETTING FOR SL30)
- B. NAV RADIO CONFIGURATION
 - SET GNC 255 RS-232 FORMAT TO "NMEA" (NO SETTING FOR SL30)
 - SET SL30/GNC255 INDICATOR TYPE TO "RESOLVER"

Figure 7-6 G5 to Serial Navigator Interconnect Drawing

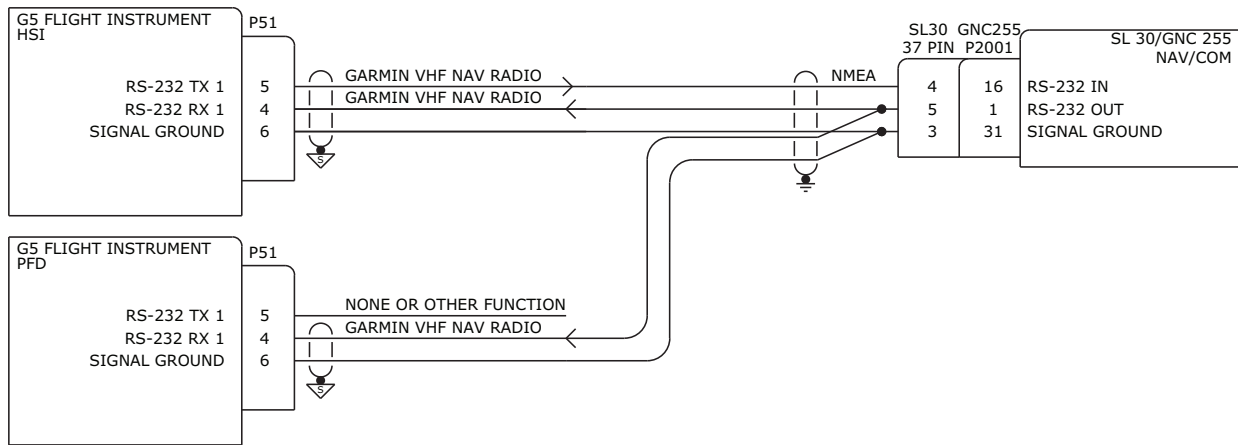

CONFIGURATION GUIDANCE

A. G5 CONFIGURATION

- HSI: SET RS-232 INPUT AND OUTPUT FORMAT TO "GARMIN VHF NAV RADIO"
- PFD: SET RS-232 INPUT FORMAT TO "GARMIN VHF NAV RADIO"

B. NAV RADIO CONFIGURATION

- SET GNC255 RS-232 FORMAT TO "NMEA" (NO SETTING FOR SL 30)
- SET SL30/GNC255 INDICATOR TYPE TO "SERIAL"

Figure 7-7 Dual G5 to GNC 255/SL30 Interconnect Drawing

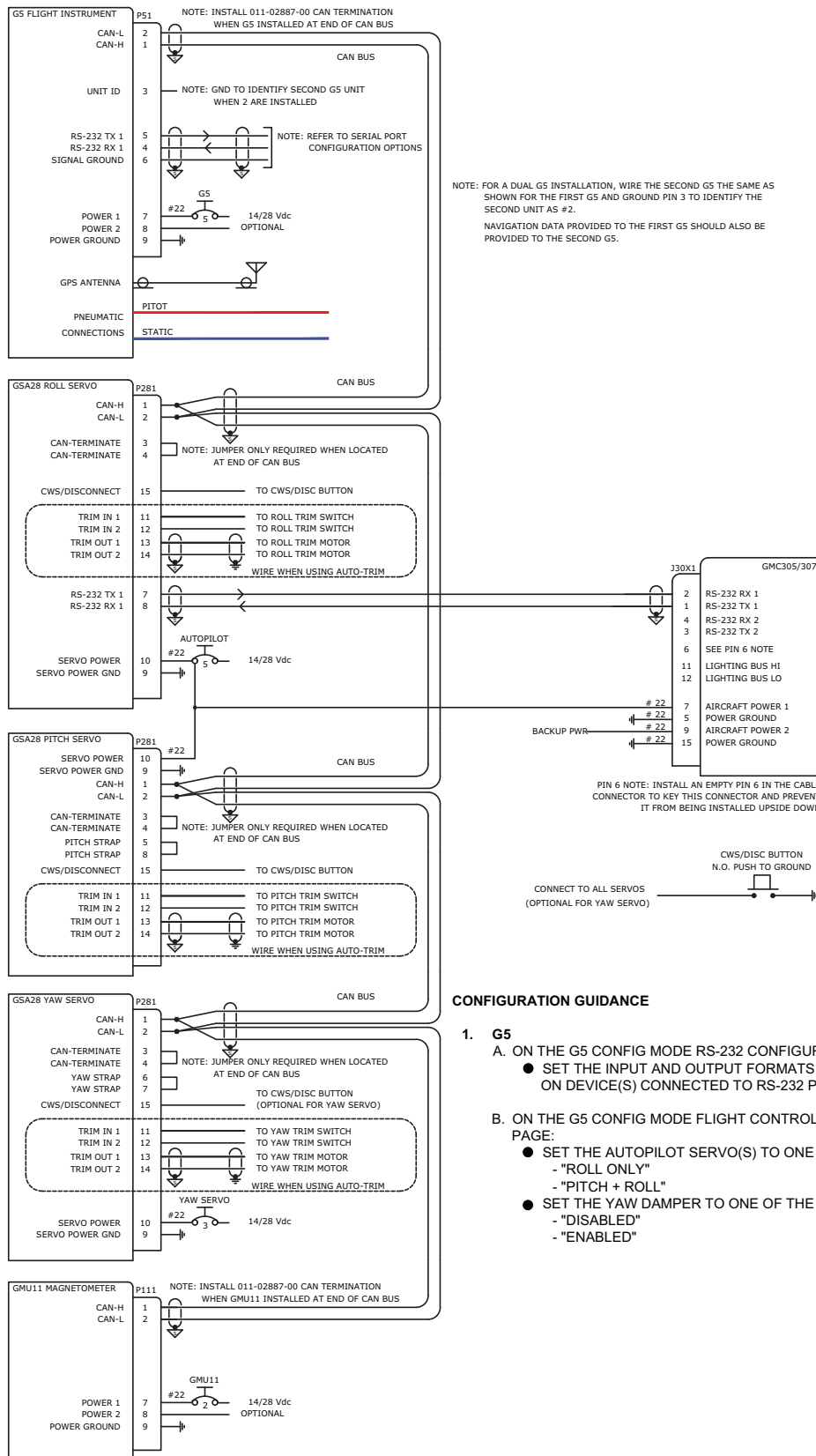

Figure 7-8 G5 Autopilot System with GMC 305/307 Interconnect Drawing

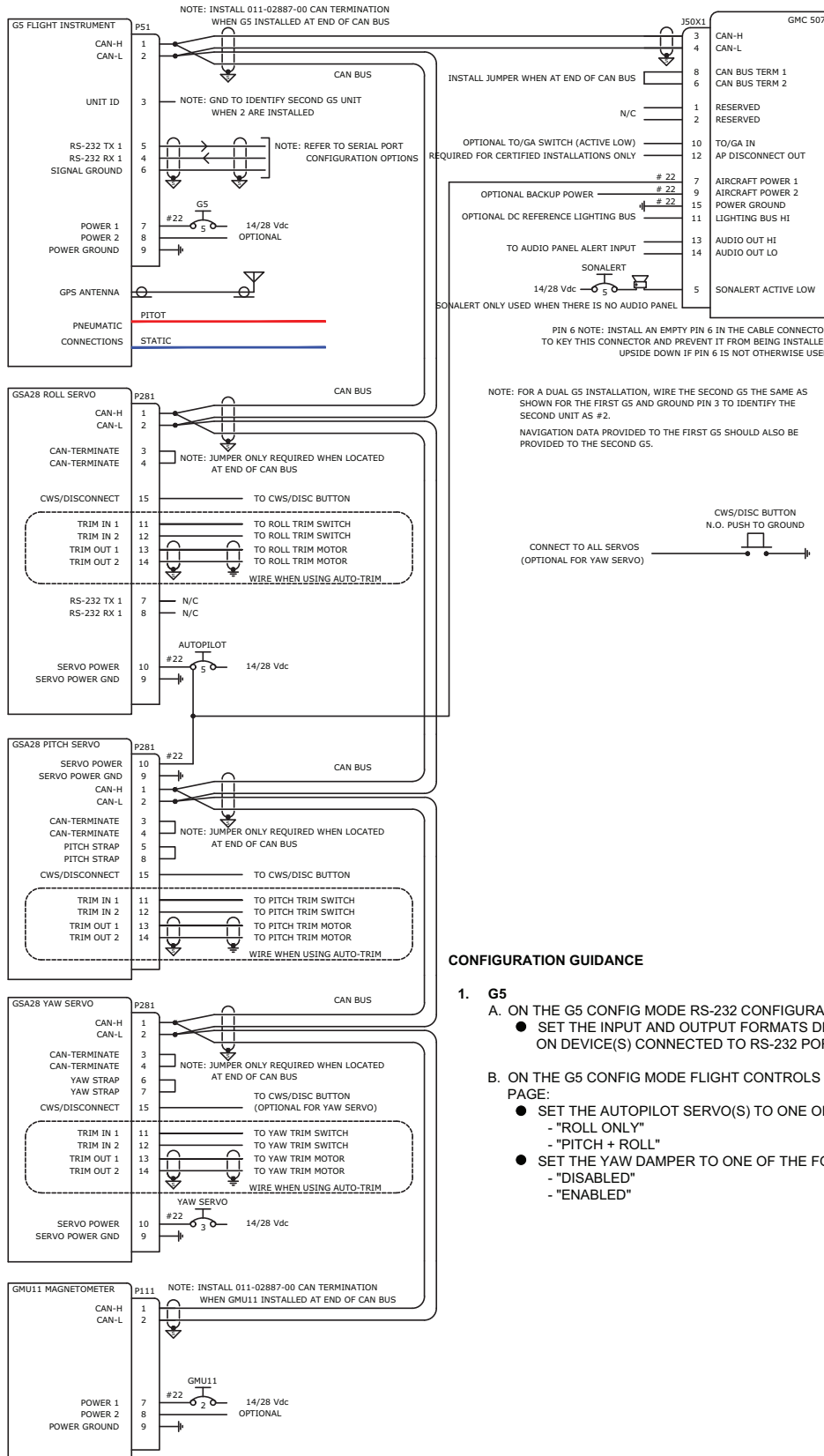
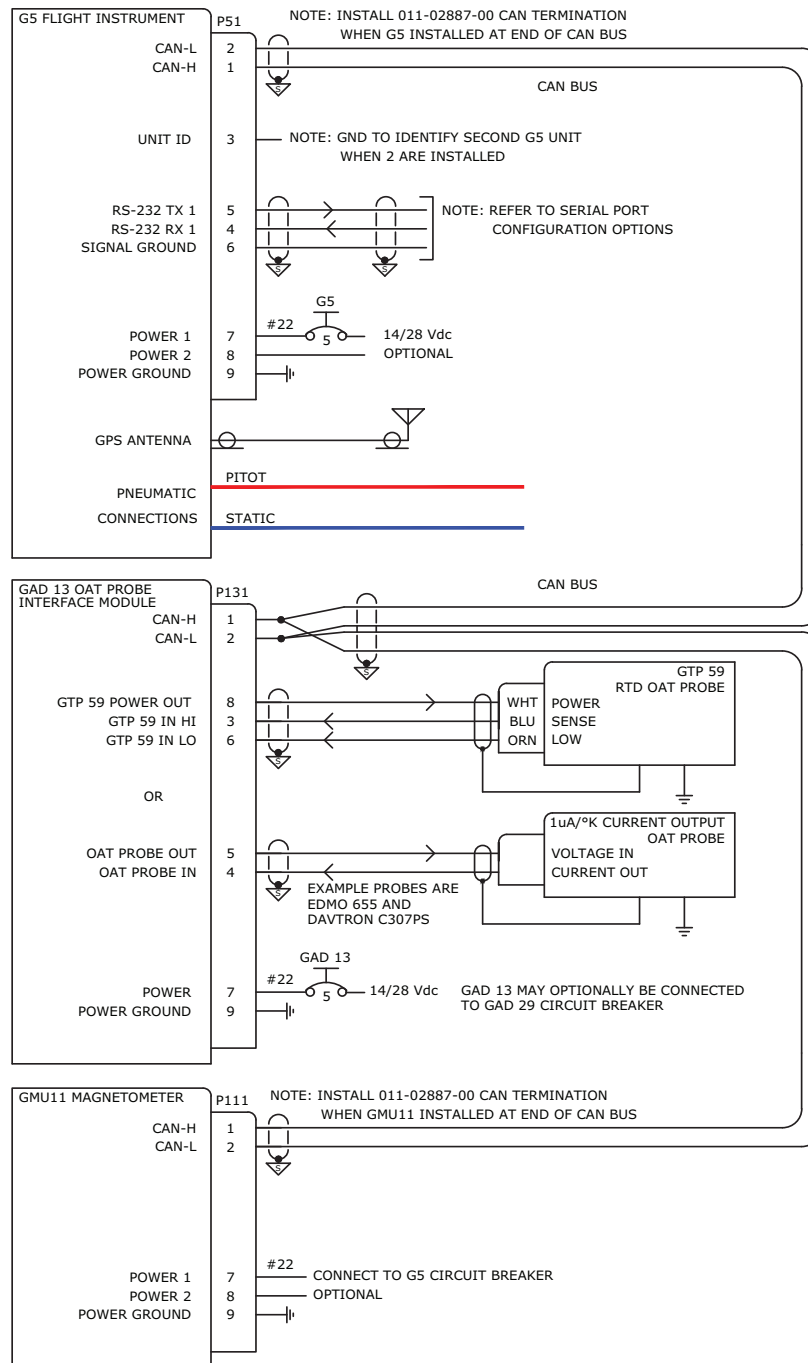

Figure 7-9 G5 Autopilot System with GMC 507 Interconnect Drawing



CONFIGURATION GUIDANCE

1. **G5**
 - A. ON THE G5 CONFIG MODE MAGNETOMETER PAGE:
 - SET THE MAGNETOMETER TO "ENABLED" WHEN A GMU 11 MAGNETOMETER IS INSTALLED
 - B. ON THE G5 CONFIG MODE AIR DATA PAGE:
 - SET THE OUTSIDE AIR TEMP SENSOR TO "ENABLED" WHEN A GAD 13 OAT PROBE MODULE IS INSTALLED

Figure 7-10 G5/GAD 13 to GMU 11 Interconnect Drawing

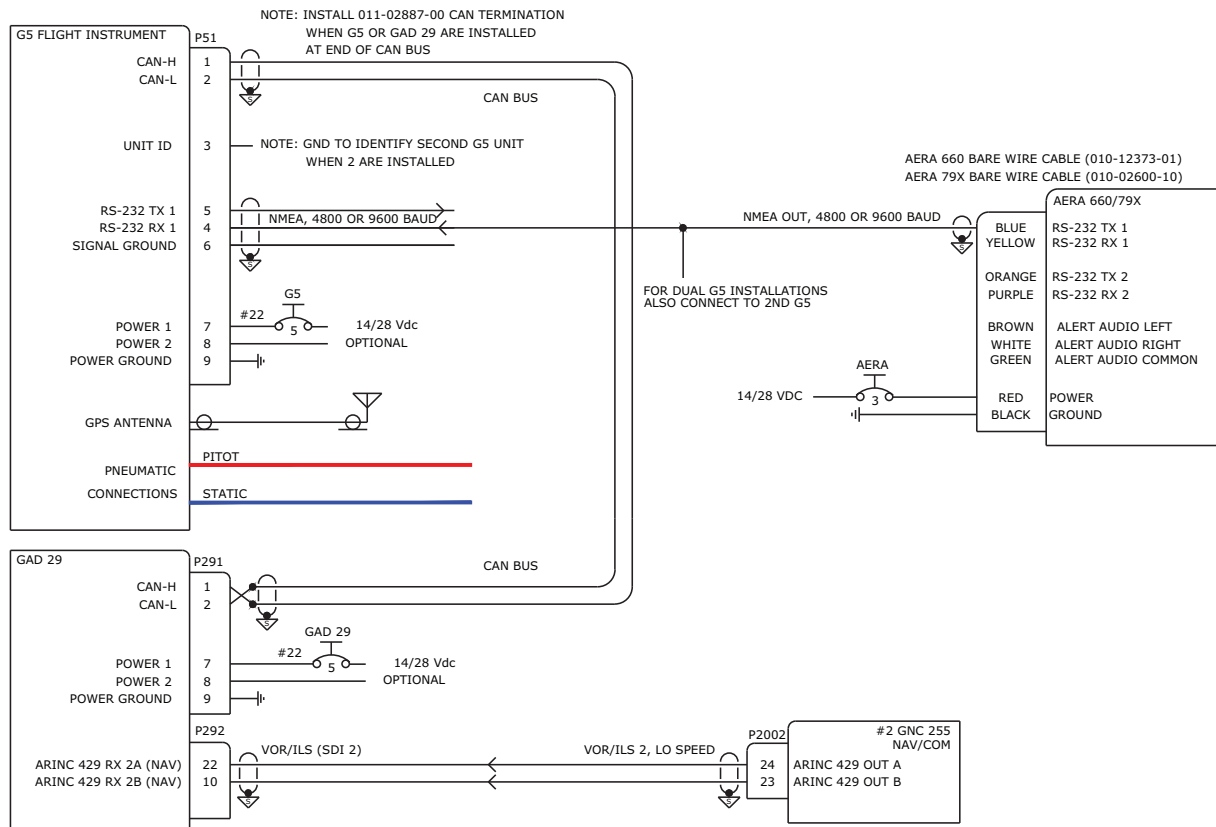

CONFIGURATION GUIDANCE

1. AERA 660/795/796

A. ON THE RS-232 INTERFACE SETUP PAGE:

- CONFIGURE SERIAL PORT 1 TO "NMEA OUT" AND MAKE SURE BAUD RATE ON G5 AND PORTABLE AGREE

2. G5

A. ON THE G5 CONFIG MODE ARINC 429 CONFIGURATION PAGE:

B. CONFIGURE ALL ARINC 429 PORTS AS SHOWN ABOVE

C. ON THE G5 CONFIG MODE RS-232 CONFIGURATION PAGE:

- SET INPUT FORMAT TO "NMEA" AND SET BAUD RATE TO 4800 OR 9600 TO MATCH PORTABLE CONFIGURATION

3. GNC 255

A. SET ARINC 429 PORT CONFIGURATION TO "VOR/ILS 2" AND "LO SPEED"

B. SET CDI INDICATOR TYPE TO "CONVERTER" ON NAV CONFIGURATION PAGE

NOTE:

THIS INSTALLATION REQUIRES G5 V6.00 OR NEWER.

Figure 7-11 G5/GAD 29 to aera/GNC 255 Dual Nav Interconnect Drawing

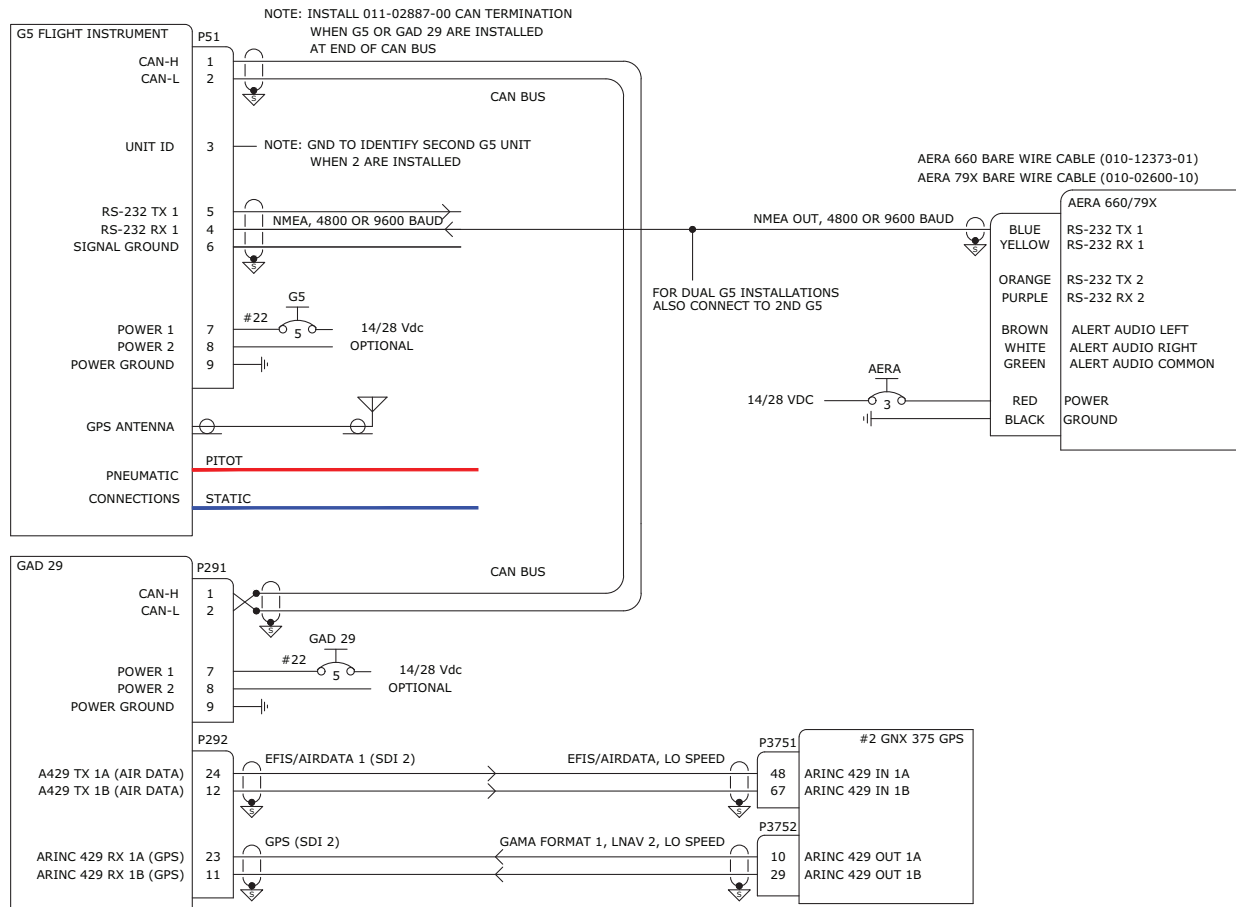

CONFIGURATION GUIDANCE

1. GNX 375

A. ON THE CONFIG MODE ARINC 429 CONFIGURATION PAGE:

- SET IN 1 SPEED TO "LOW"
- SET IN 1 DATA TO "EFIS/AIRDATA"
- SET OUT 1 SPEED TO "LOW"
- SET OUT 1 DATA TO "GAMA FORMAT 1"
- SET OUT 1 SDI TO "LNAV 2"

B. ON THE CONFIG MODE MAIN INDICATOR (ANALOG) CONFIGURATION PAGE:

- SET SELECTED COURSE TO "ALLOWED"

2. AERA 660/795/796

A. ON THE RS-232 INTERFACE SETUP PAGE:

- CONFIGURE SERIAL PORT 1 TO "NMEA OUT" AND MAKE SURE BAUD RATE ON G5 AND PORTABLE AGREE
- CONFIGURE SERIAL PORT 2 RECEIVE TO "MAPMX"

3. G5

A. ON THE G5 CONFIG MODE ARINC 429 CONFIGURATION PAGE:

- SET OUTPUT 1 TO "EFIS/AIRDATA 1 (SDI 1)"
- SET INPUT 1 TO "GARMIN GPS (SDI 2)"

B. ON THE G5 CONFIG MODE RS-232 CONFIGURATION PAGE:

- SET INPUT FORMAT TO "NMEA" AND MAKE SURE BAUD RATE ON G5 AND PORTABLE MATCH

Figure 7-12 G5/GAD 29 to aera/GNX 375 Dual Nav Interconnect Drawing

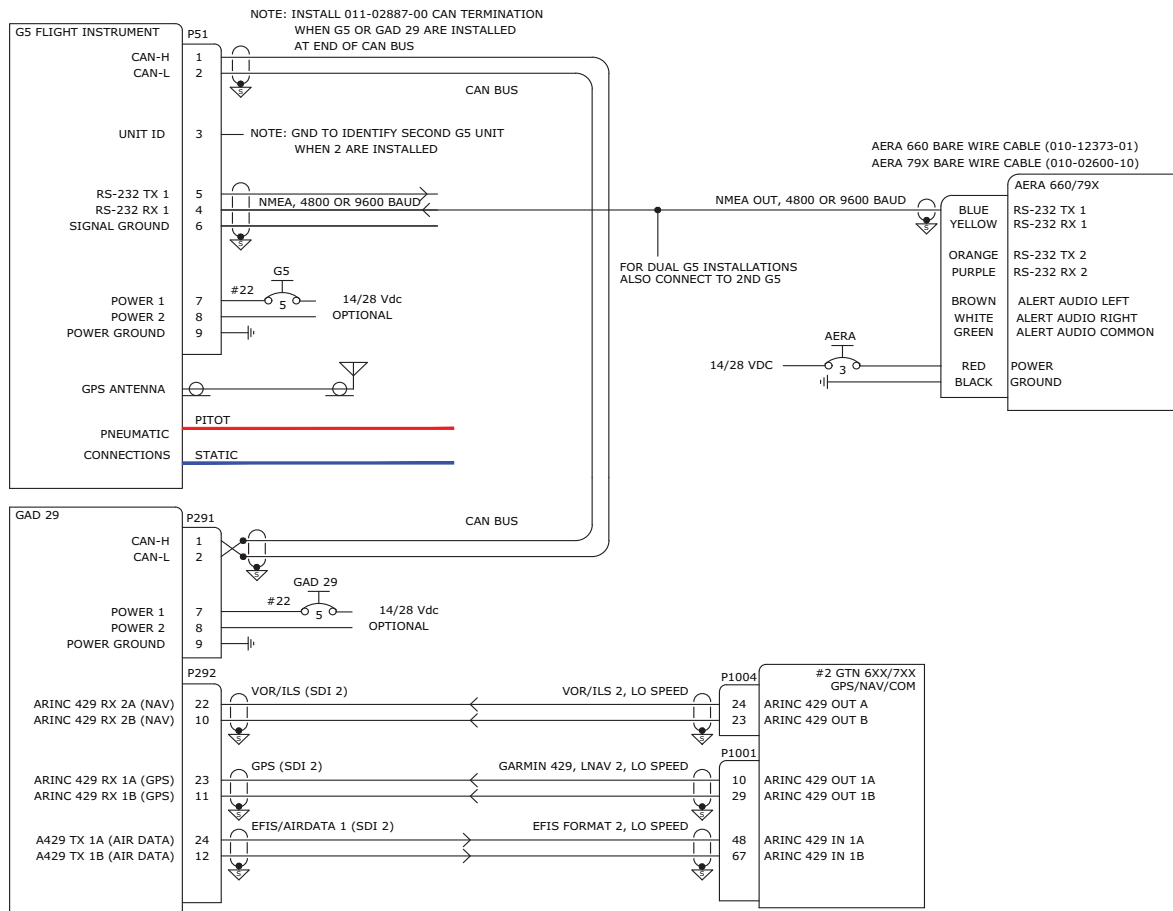

CONFIGURATION GUIDANCE

1. GTN 6XX/7XX

A. ON THE CONFIG MODE ARINC 429 CONFIGURATION PAGE:

- SET IN 1 SPEED TO "LOW"
- SET IN 1 DATA TO "EFIS FORMAT 2"
- SET OUT 1 SPEED TO "LOW"
- SET OUT 1 DATA TO "GARMIN 429"
- SET OUT 1 SDI TO "LNAV 2"

B. ON THE CONFIG MODE MAIN INDICATOR (ANALOG) CONFIGURATION PAGE:

- SET SELECTED COURSE FOR VLOC TO "IGNORED"

C. ON THE CONFIG MODE VOR/LOC/GS CONFIGURATION PAGE:

- SET NAV RADIO TO "ENABLED"
- SET TX SPEED TO "LOW"
- SET SDI TO "VOR/ILS 2"

2. AERA 660/795/796

A. ON THE RS-232 INTERFACE SETUP PAGE:

- CONFIGURE SERIAL PORT 1 TO "NMEA OUT" AND MAKE SURE BAUD RATE ON G5 AND PORTABLE AGREE

3. G5

B. ON THE G5 CONFIG MODE ARINC 429 CONFIGURATION PAGE:

- SET OUTPUT 1 TO "EFIS/AIRDATA 1 (SDI 2)"
- SET INPUT 1 TO "GARMIN GPS (SDI 2)"
- SET INPUT 2 TO "GARMIN VOR/ILS (SDI 2)"

B. ON THE G5 CONFIG MODE RS-232 CONFIGURATION PAGE:

- SET INPUT FORMAT TO "NMEA" AND MAKE SURE BAUD RATE ON G5 AND PORTABLE MATCH

Figure 7-13 G5/GAD 29 to aera/GTN 6XX/7XX Dual Nav Interconnect Drawing

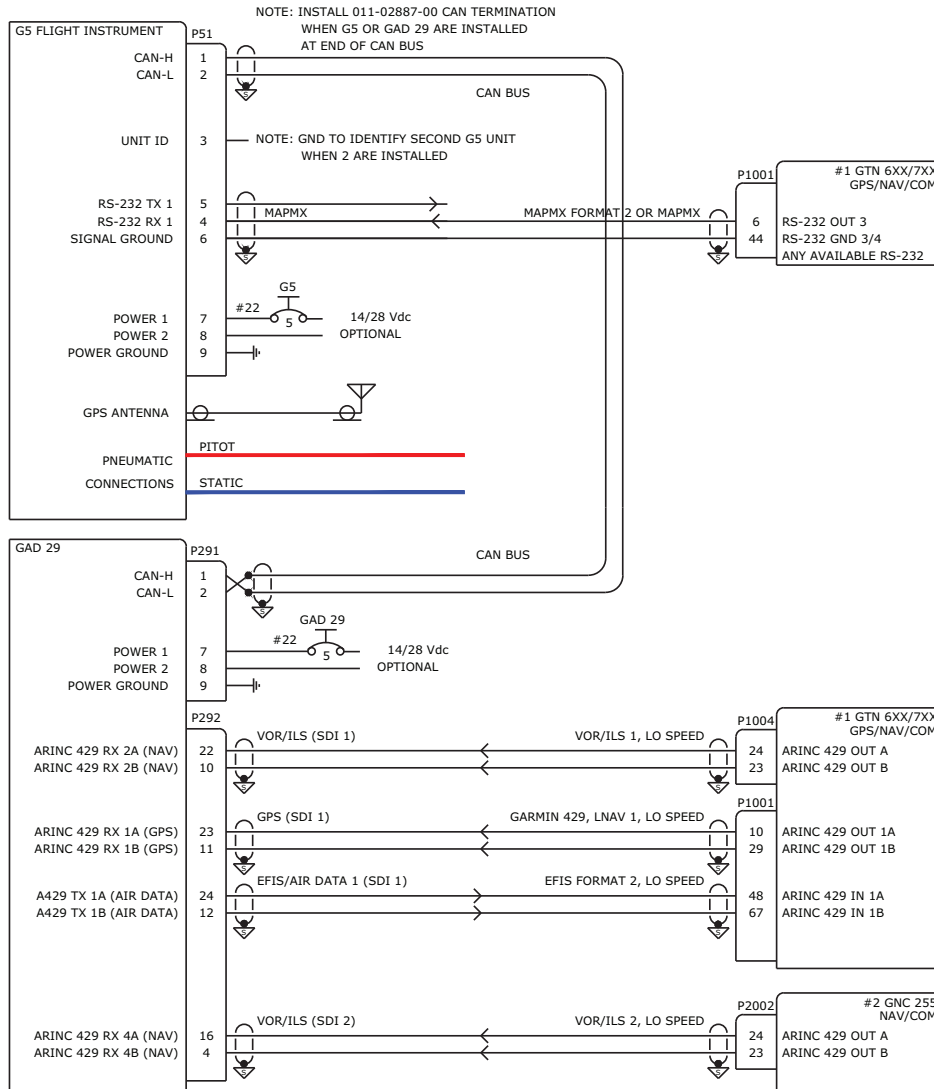

CONFIGURATION GUIDANCE

1. GTN 6XX/7XX

- A. ON THE CONFIG MODE ARINC 429 CONFIGURATION PAGE:
 - CONFIGURE ALL ARINC 429 PORTS AS SHOWN ABOVE
- B. ON THE CONFIG MODE MAIN INDICATOR (ANALOG) CONFIGURATION PAGE:
 - SET SELECTED COURSE FOR VLOC TO "IGNORED"
- C. ON THE CONFIG MODE VOR/LOC/GS CONFIGURATION PAGE:
 - SET NAV RADIO TO "ENABLED"
 - SET TX SPEED TO "LOW"
 - SET SDI TO "VOR/ILS 1"
- D. ON THE RS-232 CONFIG PAGE
 - SET CHNL 3 INPUT TO "MAPMX FORMAT 2" WHEN THIS FORMAT IS AVAILABLE
 - SET CHNL 3 OUTPUT TO "MAPMX" WHEN "MAPMX FORMAT 2" INPUT NOT AVAILABLE

2. G5

- A. ON THE G5 CONFIG MODE ARINC 429 CONFIGURATION PAGE:
 - CONFIGURE IN/OUT PORTS AS SHOWN ABOVE
- B. ON THE G5 CONFIG MODE RS-232 CONFIGURATION PAGE:
 - SET INPUT FORMAT TO "MAPMX"

3. GNC 255

- A. SET ARINC 429 PORT CONFIGURATION TO "VOR/ILS 2" AND "LO SPEED"
- B. SET CDI INDICATOR TYPE TO "CONVERTER" ON NAV CONFIGURATION PAGE

Figure 7-14 G5/GAD 29 to GNC 255/GTN 6XX/7XX Dual Nav Interconnect Drawing

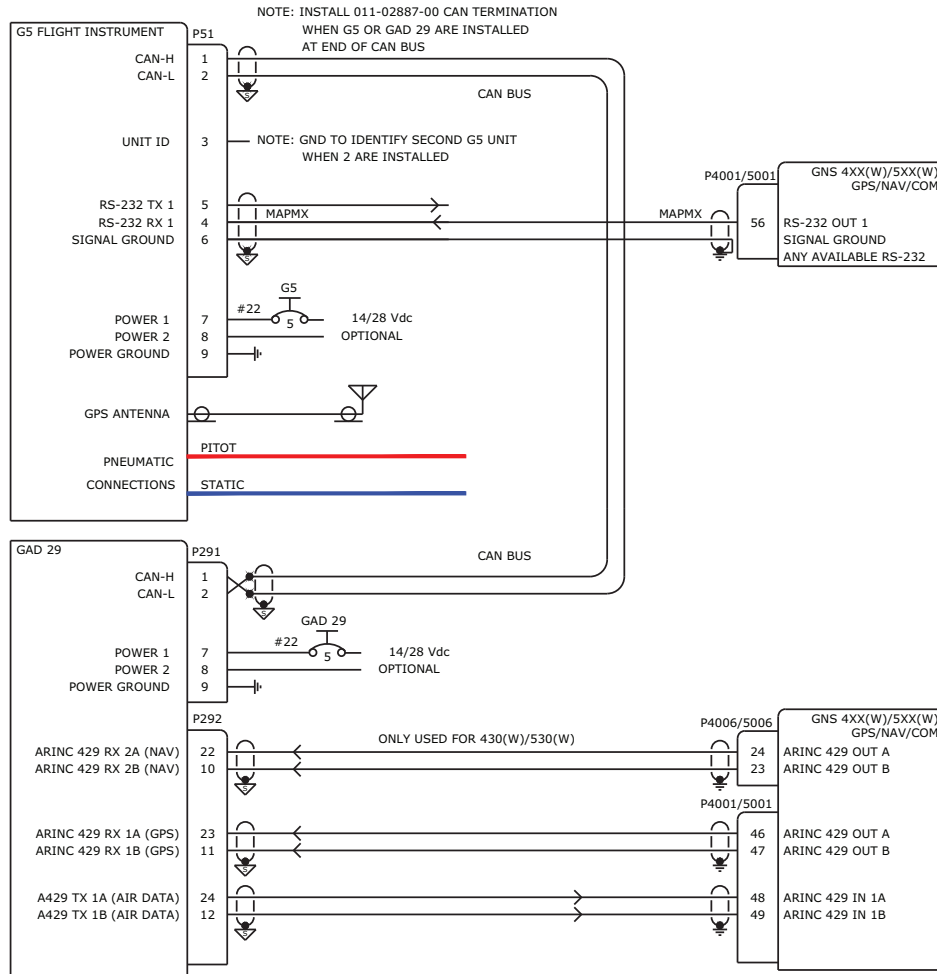

CONFIGURATION GUIDANCE

1. GNS 4XX(W)/5XX(W)

- A. ON THE CONFIG MODE MAIN ARINC 429 CONFIGURATION PAGE:
 - SET IN 1 SPEED TO "LOW"
 - SET IN 1 DATA TO "EFIS/AIRDATA"
 - SET OUT SPEED TO "LOW"
 - SET OUT DATA TO "GAMA 429"
 - SET SDI TO "LNAV 1"
- B. ON THE CONFIG MODE MAIN CDI/OBS CONFIGURATION PAGE (GNS 430(W)/530(W) ONLY):
 - PRESS MENU AND THEN SELECT "IGNORE SEL CRS FOR VLOC?"
 - MENU WILL DISPLAY "ALLOW SEL COURSE FOR VLOC?" WHEN SET CORRECTLY
- C. ON THE CONFIG MODE VOR/LOC/GS ARINC 429 CONFIGURATION PAGE (GNS 430(W)/530(W) ONLY):
 - SET RX AND TX SPEED TO "LOW"
 - SET SDI TO "VOR/ILS 1"
- D. ON THE MAIN RS-232 CONFIG PAGE
 - SET CHNL 1 INPUT TO "OFF"
 - SET CHNL 1 OUTPUT TO "MAPMX" (WAAS UNITS) OR "AVIATION" (NON-WAAS UNITS)

2. G5

- A. ON THE G5 CONFIG MODE ARINC 429 CONFIGURATION PAGE:
 - SET OUTPUT 1 TO "EFIS/AIRDATA 1 (SDI 1)"
 - SET INPUT 1 TO "GARMIN GPS (SDI 1)"
 - SET INPUT 2 TO "GARMIN VOR/ILS (SDI 1)"
- B. ON THE G5 CONFIG MODE RS-232 CONFIGURATION PAGE:
 - SET INPUT FORMAT TO "MAPMX" (WAAS UNITS) OR "AVIATION" (NON-WAAS UNITS)

Figure 7-16 G5/GAD 29 to GNS 4XX/5XX Interconnect Drawing

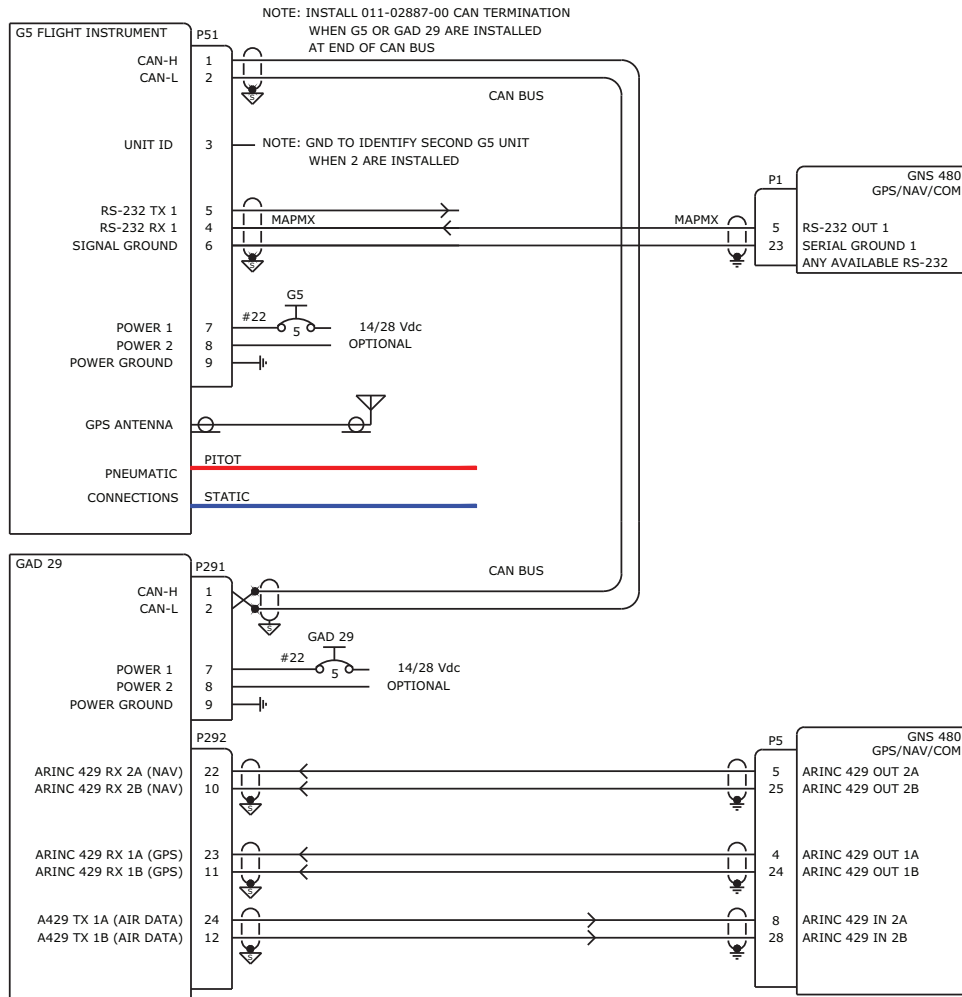

CONFIGURATION GUIDANCE

1. GNS 480

A. ON THE GND MAINT MODE ARINC 429 SETUP PAGE:

- SET CH_IN 2 SEL TO "EFIS"
- SET CH_IN 2 SPEED TO "LOW"
- SET CH_IN 2 SDI TO "SYS1"
- SET CH_OUT 1 SEL TO "GAMA 429 NO FP"
- SET CH_OUT 1 SPEED TO "LOW"
- SET CH_OUT 1 SDI TO "SYS1"
- SET CH_OUT 2 SEL TO "VOR/ILS"
- SET CH_OUT 2 SPEED TO "LOW"
- SET CH_OUT 2 SDI TO "SYS1"

B. ON THE GND MAINT MODE RESOLVER INTERFACE SETUP PAGE:

- SET RESOLVER TO "NOT INSTALLED"

C. ON THE GND MAINT MODE MISCELLANEOUS SETUP PAGE:

- SET CDI SELECT TO "USE"

D. ON THE GND MAINT MODE SERIAL SETUP PAGE:

- SET CHNL 1 OUTPUT TO "MAPMX"

2. G5

A. ON THE G5 CONFIG MODE ARINC 429 CONFIGURATION PAGE:

- SET OUTPUT 1 TO "EFIS/AIRDATA 1 (SDI 1)"
- SET INPUT 1 TO "GARMIN GPS (SDI 1)"
- SET INPUT 2 TO "GARMIN VOR/ILS (SDI 1)"

B. ON THE G5 CONFIG MODE RS-232 CONFIGURATION PAGE:

- SET INPUT FORMAT TO "MAPMX"

Figure 7-17 G5/GAD 29 to GNS 480 Interconnect Drawing

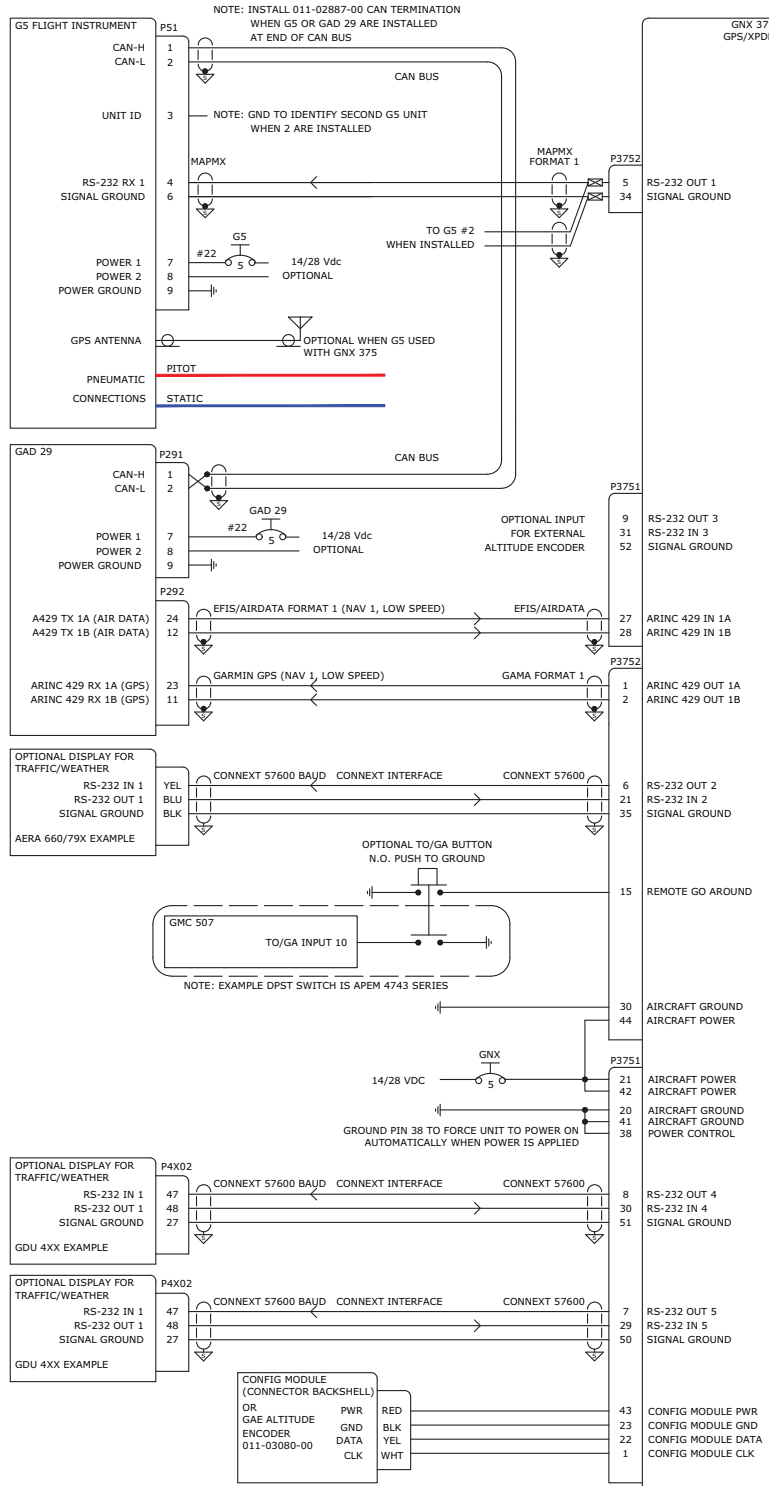
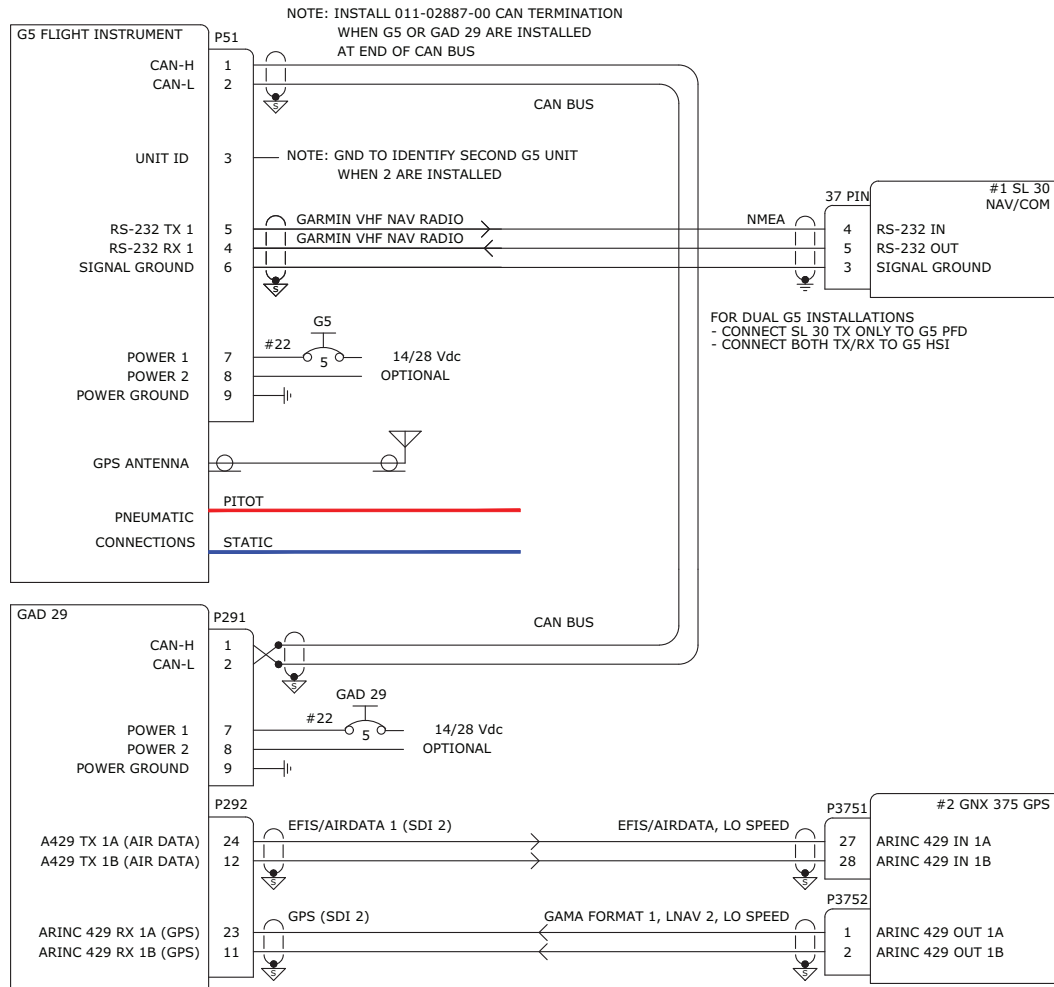

Figure 7-18 G5/GAD 29 to GNX 375 Interconnect Drawing



CONFIGURATION GUIDANCE

1. GNX 375

A. ON THE CONFIG MODE ARINC 429 CONFIGURATION PAGE:

- SET IN 1 SPEED TO "LOW"
- SET IN 1 DATA TO "EFIS/AIRDATA"
- SET OUT 1 SPEED TO "LOW"
- SET OUT 1 DATA TO "GAMA FORMAT 1"
- SET OUT 1 SDI TO "LNAV 2"

B. ON THE CONFIG MODE MAIN INDICATOR (ANALOG) CONFIGURATION PAGE:

- SET SELECTED COURSE TO "ALLOWED"

2. SL 30

A. SET SL30 INDICATOR TYPE TO "SERIAL"

3. G5

A. ON THE G5 CONFIG MODE ARINC 429 CONFIGURATION PAGE:

- SET OUTPUT 1 TO "EFIS/AIRDATA 1 (SDI 2)"
- SET INPUT 1 TO "GARMIN GPS (SDI 2)"

B. ON THE G5 CONFIG MODE RS-232 CONFIGURATION PAGE:

- SET INPUT FORMAT TO "GARMIN VHF NAV RADIO" FOR G5 PFD AND G5 HSI
- SET OUTPUT FORMAT TO "GARMIN VHF NAV RADIO" FOR G5 HSI ONLY IN DUAL G5 INSTALLATION. SET OUTPUT FORMAT TO "NONE" FOR G5 PFD IN DUAL G5 INSTALLATION

Figure 7-20 G5/GAD 29 to GNX 375/SL 30 Interconnect Drawing

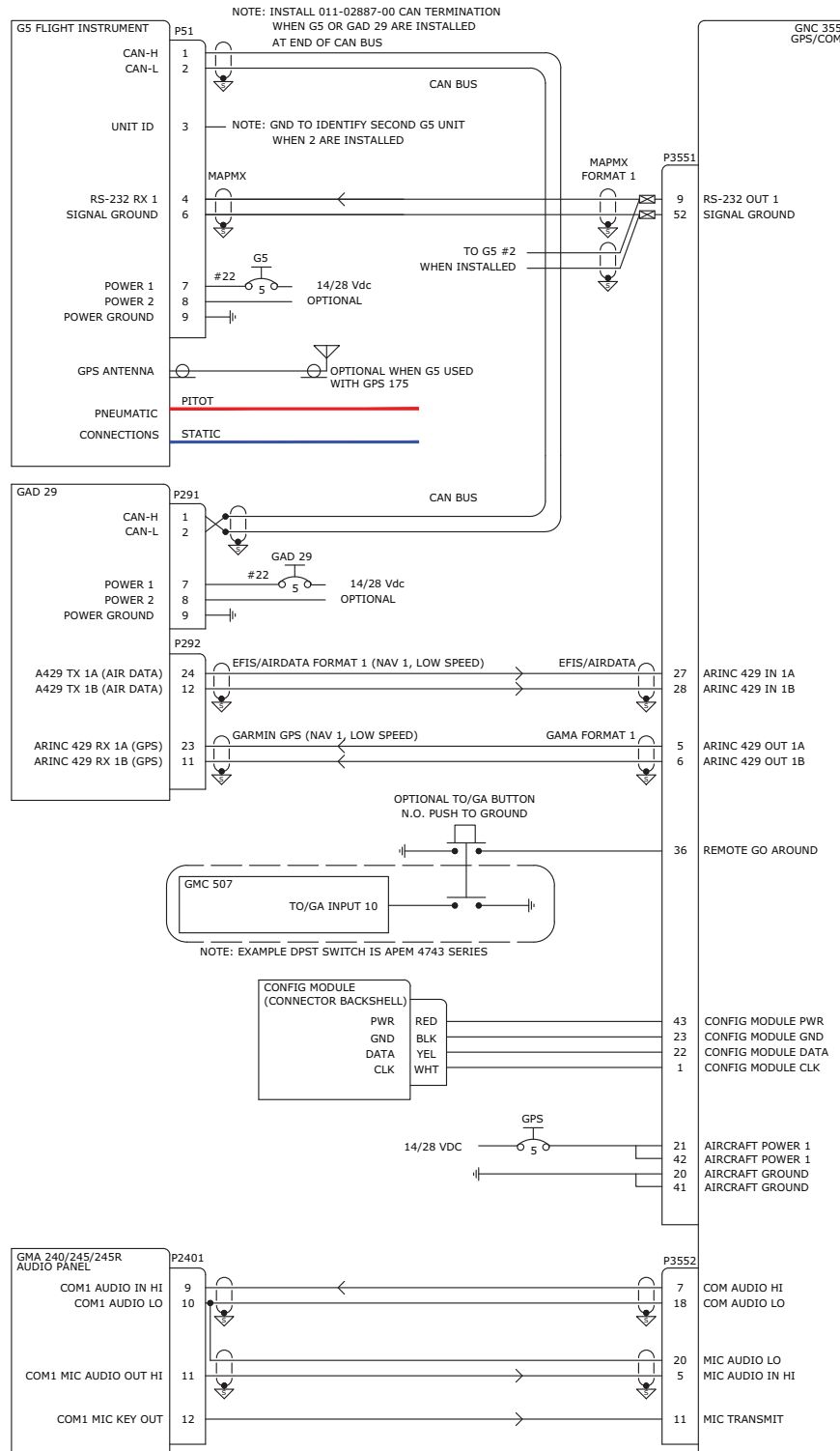

- NOTES:**
1. CONFIGURE THE RS-232 AND ARINC 429 PORTS PER THE LABELING ON THE ABOVE WIRING DIAGRAM.
 2. ON THE GNC 355 MAIN INDICATOR (ANALOG) CONFIG MODE SETUP PAGE, SET THE SELECTED COURSE FIELD TO "ALLOWED".
 3. THE GNC 355 COM RADIO MAY BE CONNECTED AS COM1 OR COM2 ON THE AUDIO PANEL.

Figure 7-21 G5/GAD 29 to GNC 355 Interconnect Drawing

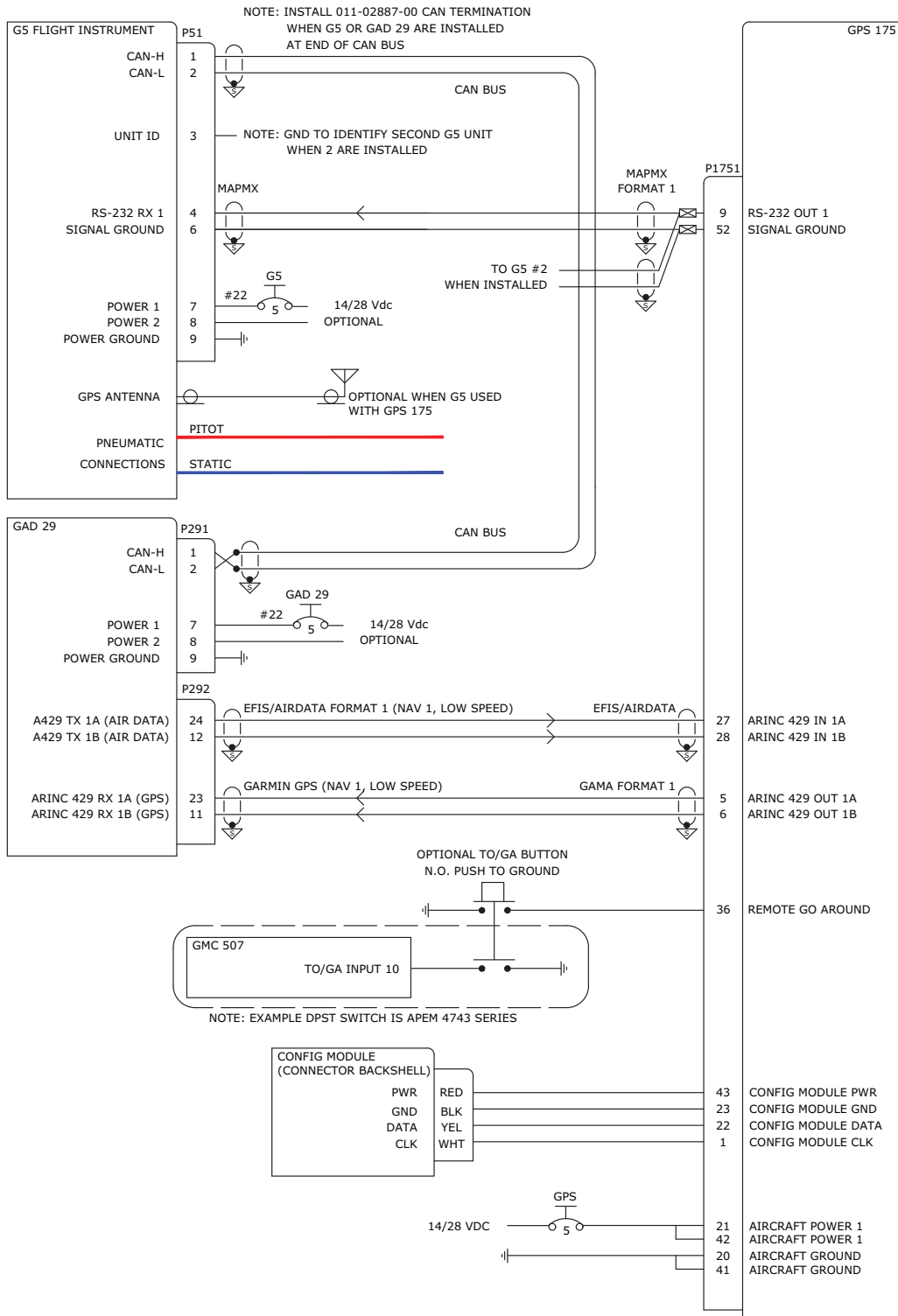

- NOTES:**
1. CONFIGURE THE RS-232 AND ARINC 429 PORTS PER THE LABELING ON THE ABOVE WIRING DIAGRAM.
 2. ON THE GPS 175 MAIN INDICATOR (ANALOG) CONFIG MODE SETUP PAGE, SET THE SELECTED COURSE FIELD TO "ALLOWED".

Figure 7-22 G5/GAD 29 to GPS 175 Interconnect Drawing

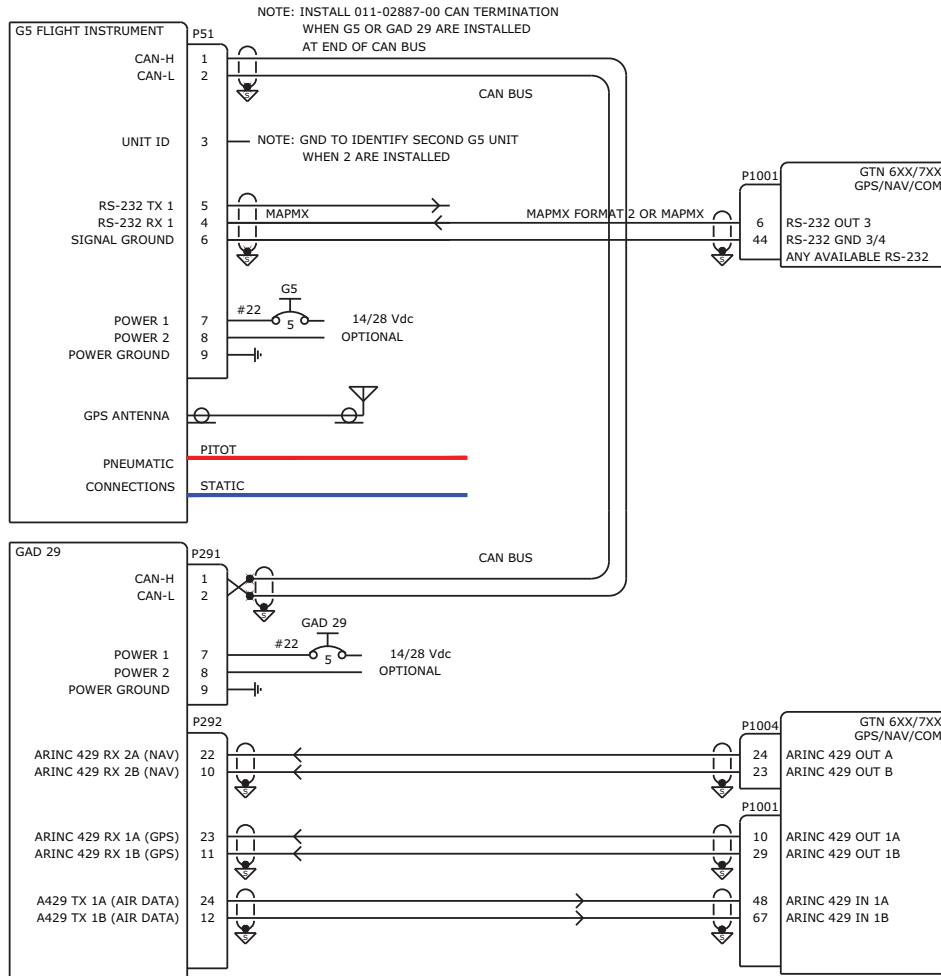

CONFIGURATION GUIDANCE

1. GTN 6XX/7XX

- A. ON THE CONFIG MODE ARINC 429 CONFIGURATION PAGE:
 - SET IN 1 SPEED TO "LOW"
 - SET IN 1 DATA TO "EFIS FORMAT 2"
 - SET OUT 1 SPEED TO "LOW"
 - SET OUT 1 DATA TO "GARMIN 429" (GTN V6.50 AND LATER)
 - SET OUT 1 DATA TO "GAMA FORMAT 1" WHEN "GARMIN 429" NOT AVAILABLE
 - SET OUT 1 SDI TO "LNAV 1"
- B. ON THE CONFIG MODE MAIN INDICATOR (ANALOG) CONFIGURATION PAGE:
 - SET SELECTED COURSE FOR VLOC TO "IGNORED"
- C. ON THE CONFIG MODE VOR/LOC/GS CONFIGURATION PAGE:
 - SET NAV RADIO TO "ENABLED"
 - SET TX SPEED TO "LOW"
 - SET SDI TO "VOR/ILS 1"
- D. ON THE RS-232 CONFIG PAGE
 - SET CHNL 3 INPUT TO "MAPMX FORMAT 2" WHEN THIS FORMAT IS AVAILABLE
 - SET CHNL 3 OUTPUT TO "MAPMX" WHEN "MAPMX FORMAT 2" INPUT NOT AVAILABLE

2. G5

- A. ON THE G5 CONFIG MODE ARINC 429 CONFIGURATION PAGE:
 - SET OUTPUT 1 TO "EFIS/AIRDATA 1 (SDI 1)"
 - SET INPUT 1 TO "GARMIN GPS (SDI 1)"
 - SET INPUT 2 TO "GARMIN VOR/ILS (SDI 1)"
- B. ON THE G5 CONFIG MODE RS-232 CONFIGURATION PAGE:
 - SET INPUT FORMAT TO "MAPMX"

Figure 7-23 G5/GAD 29 to GTN 6XX/7XX Interconnect Drawing

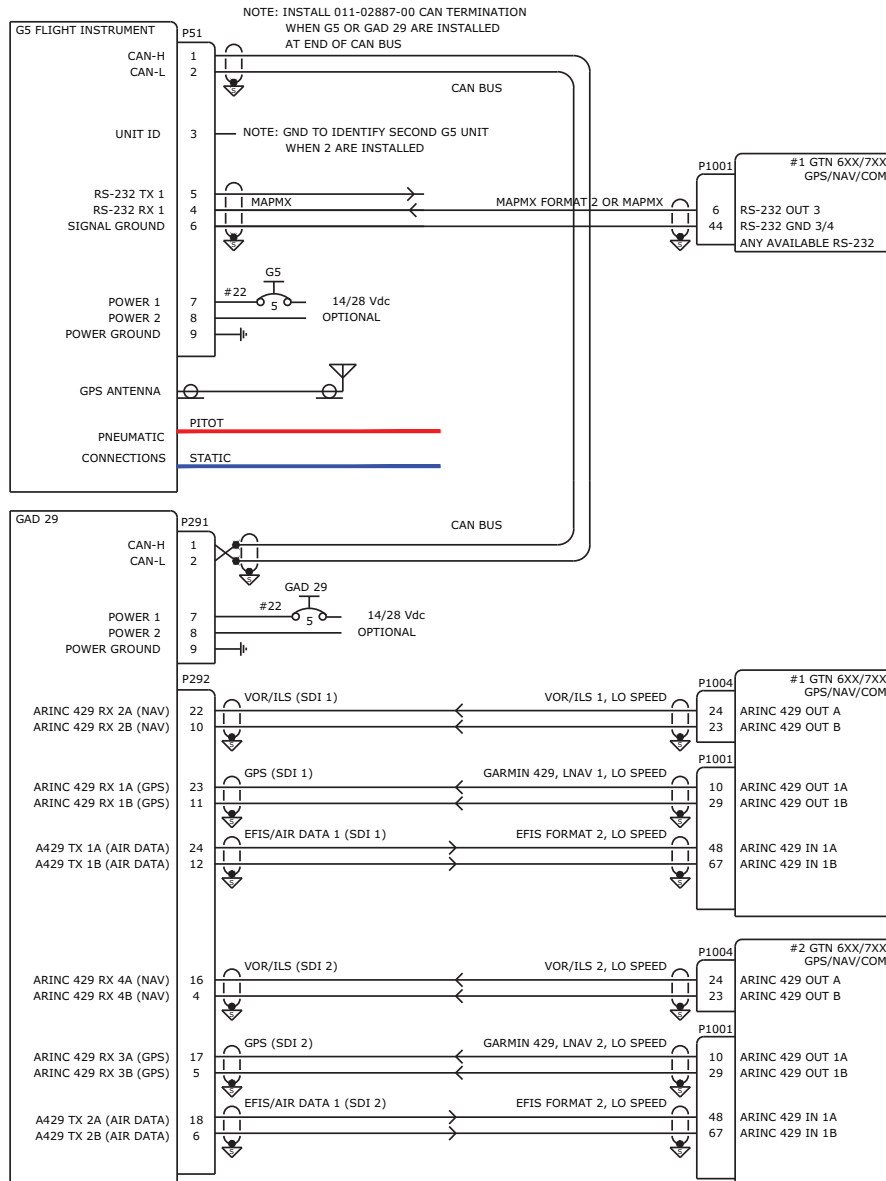

CONFIGURATION GUIDANCE

1. GTN 6XX/7XX

- A. ON THE CONFIG MODE ARINC 429 CONFIGURATION PAGE:
 - CONFIGURE ALL ARINC 429 PORTS AS SHOWN ABOVE
- B. ON THE CONFIG MODE MAIN INDICATOR (ANALOG) CONFIGURATION PAGE:
 - SET SELECTED COURSE FOR VLOC TO "IGNORED"
- C. ON THE CONFIG MODE VOR/LOC/GS CONFIGURATION PAGE:
 - SET NAV RADIO TO "ENABLED"
 - SET TX SPEED TO "LOW"
 - SET SDI TO "VOR/ILS 1" FOR #1 GTN, "VOR/ILS 2" FOR #2 GTN
- D. ON THE RS-232 CONFIG PAGE
 - SET CHNL 3 INPUT TO "MAPMX FORMAT 2" WHEN THIS FORMAT IS AVAILABLE
 - SET CHNL 3 OUTPUT TO "MAPMX" WHEN "MAPMX FORMAT 2" INPUT NOT AVAILABLE

2. G5

- A. ON THE G5 CONFIG MODE ARINC 429 CONFIGURATION PAGE:
 - CONFIGURE IN/OUT PORTS AS SHOWN ABOVE
- B. ON THE G5 CONFIG MODE RS-232 CONFIGURATION PAGE:
 - SET INPUT FORMAT TO "MAPMX"

Figure 7-24 G5/GAD 29 to GTN 6XX/7XX Dual Nav Interconnect Drawing

8 G5 CONFIGURATION AND POST INSTALLATION CHECKOUT

The checkout procedures in this section are recommended to be performed after installing the G5. The calibration procedures are required to be performed after installing the G5. It is assumed the person performing these checks is familiar with the aircraft, has a working knowledge of typical avionics systems, and has experience using the test equipment defined in this section.



NOTE

See G5 Pilot's Guide for operational instructions.



NOTE

Some procedures in this section require the GPS receiver is receiving sufficient satellite signal to compute a present position. This requires outdoor line of sight to GPS satellite signals or a GPS indoor repeater.



NOTE

As these procedures involve engine run-up and moving the aircraft, it is recommended the installer read this entire section before beginning the checkout procedure.



NOTE

All test equipment should have current calibration records.



CAUTION

Be sure to check all aircraft control movements before flight is attempted to ensure the wiring harness does not touch any moving part.

8.1 Recommended Test Equipment

The following test equipment is recommended to conduct and complete all post installation checkout procedures in this section:

- Digital Multi-Meter (DMM) for power troubleshooting and wiring connection check
- Ground power unit capable of supplying 14/28 Vdc power to the aircraft systems and avionics
- Outdoor line of sight to GPS satellite signals or GPS indoor repeater
- Digital level or equivalent
- Pitot/static ramp tester (only required if unit fails a periodic static system test)

8.2 Configuration Mode

All of the configuration and calibration procedures in this section are performed in configuration mode. To enter configuration mode, hold down the knob while powering on the G5.



Figure 8-1 Entering Configuration Mode

8.3 Software Loading Procedure

G5 software loading can be performed in either normal or configuration mode. Manually loading software to the G5 is not required when the G5 is installed as part of a G3X™ system.

1. Power on the G5, then insert a properly formatted microSD™ card into the microSD™ card slot.



NOTE

It is also acceptable to insert the microSD™ card before powering on the unit.

2. A software update message appears on the screen. Select OK to begin the update.



NOTE

The software update message will only be displayed if the version of software to be loaded is newer than the version currently on the unit.

3. The unit will reboot to the software update screen and the software update will begin automatically. This screen will show the progress of the software update.
4. Ensure power is not removed while the update is being performed.
5. The unit will reboot after the update is complete.
6. The new software version may be viewed while the unit powers on or in the configuration mode menu.

8.4 Configuration Pages

8.4.1 Device Information Page



NOTE

When a G5 is installed as part of a G3X system, some configuration pages are not available because configuration settings are automatically transferred from the GDU™ 37X/4XX to the G5.

The Device Information page displays LRU (device) specific information such as the software versions of devices connected to the G5. The devices listed on this page are dependent upon the Installation Type setting (G3X System Backup or Standalone Instrument). Faults are indicated by a red "X" next to the affected LRU.

Device Information		
<input checked="" type="checkbox"/>	ROLL	GSA 28 3.20
<input checked="" type="checkbox"/>	PITCH	GSA 28 3.20
<input checked="" type="checkbox"/>	YD	GSA 28 3.20
<input checked="" type="checkbox"/>	GMC	GMC 305 2.00

Figure 8-2 Device Information Page

The G5 can be configured as a Standalone Unit or (if connected to a G3X system) it will automatically be configured as G3X Backup Unit. When connected to a G3X system, the G5 will not allow the Installation Type setting to be changed (as long as the G5 is communicating with G3X LRUs). To select the Installation Type:

1. Power on the unit in configuration mode.
2. Select Device Information.
3. Scroll to select Installation Type, and press the knob.
4. Select either G3X System Backup or Standalone Instrument.

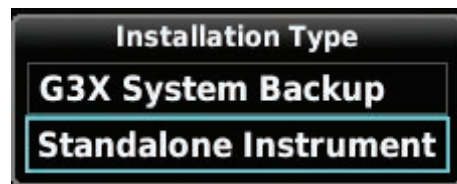

Figure 8-3 Installation Type Page

8.4.2 Attitude Configuration Page

The Attitude Configuration page is used to configure user display preferences and to complete the post-installation calibration procedures.

Table 8-1 Attitude Configuration Settings

Configuration Setting	Description
Indicator Type	<p>Select Normal to display a triangular aircraft reference symbol indicator on the PFD (similar to single cue). Select Alternate to display a cross-pointer aircraft reference symbol (similar to dual-cue).</p> <p>This setting is only present when the Installation Type setting is configured as a Standalone Unit and the installation does not have an autopilot configured.</p>
Pitch Display	<p>Adjusts the scale of the pitch ladder on the PFD. Compact spaces the pitch markings closer together. Normal mimics the spacing of typical mechanical attitude indicators. Expanded spaces the markings further apart.</p>

Table 8-1 Attitude Configuration Settings



<p>Roll Display</p>	<p>The roll (bank angle) indication may be selected to be a Ground Pointer (default) or a Sky Pointer configuration.</p>  <p>For the more common Ground Pointer configuration, both the roll arc and the pitch ladder remain anchored to the horizon and the roll pointer beneath the roll arc points to the present roll angle.</p>  <p>For the Sky Pointer configuration, the pitch ladder continues to roll with the horizon, but the roll arc remains fixed and centered in the display. The roll pointer beneath the roll arc moves with the horizon and in the opposite direction to aircraft roll.</p>
<p>Vibration Test</p>	<p>Validates the vibration characteristics of the G5 installation. See Section 8.4.6.2 for more information.</p>

Table 8-1 Attitude Configuration Settings

<p>Calibrate Yaw Offset</p>	<p>Allows for direct manual entry of the present yaw offset when the instrument panel to which the G5 is mounted is not perpendicular to the aircraft centerline. The limit on this setting is +/- 15 degs. Positive is clockwise.</p> 
<p>Calibrate Pitch/Roll</p>	<p>Calibrates the G5's pitch and roll measurements to a known level attitude. See Section 8.4.6.1 for more information.</p>
<p>Pitch Calibration</p>	<p>Allows for direct manual entry or adjustment of the present pitch offset. The limit on this setting is +/- 30 degs. Positive is pitch up. For example, an aircraft that is continuously indicating a pitch attitude that is 2 degs high would need to reduce this pitch offset value by 2 degs.</p>
<p>Roll Calibration</p>	<p>Allows for direct manual entry or adjustment of the present roll offset. The limit on this setting is +/- 2 degs. Positive is roll right.</p>
<p>User Pitch Offset</p>	<p>If disabled, the pitch offset cannot be adjusted and will default to zero (standalone installation only). Enables and disables the pitch offset in normal mode. This setting is only present when the Installation Type setting is configured as a Standalone Unit.</p>
<p>Automatic Declutter</p>	<p>Enables and disables the automatic change from the HSI page to the PFD page when the aircraft enters an unusual pitch/roll attitude.</p>

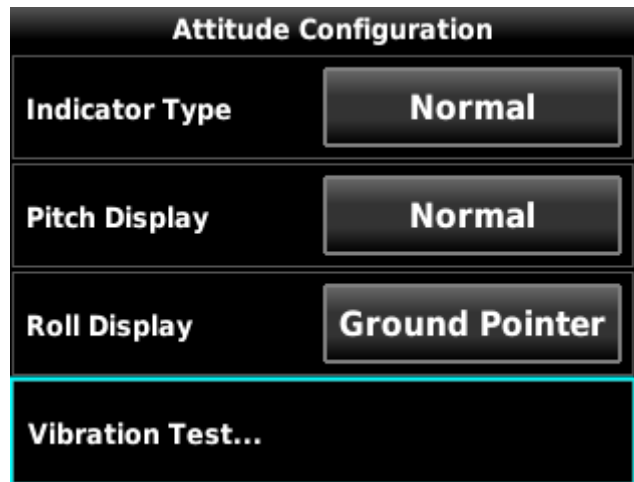

Figure 8-4 Attitude Configuration Page

8.4.3 Air Data Configuration Page

The Air Data Configuration page is used to configure user display preferences and to complete the post-installation calibration procedures.

Table 8-2 Air Data Configuration Settings

Configuration Setting	Description
Air Data Sensors	Select Disabled to disable the G5's internal air data sensors and hide airspeed, altitude, and vertical speed information on the PFD. This option is intended for single standalone G5 installations where the pitot/static inputs are not connected. This setting is only present when the Installation Type setting is configured as a Standalone Unit and the installation does not have an autopilot configured.
Vertical Speed Indicator	Configures the G5's PFD vertical speed indicator to display ± 1500 fpm, ± 2000 fpm, or ± 3000 fpm.
Calibrate Static Pressure	Performs a field calibration of the G5's static pressure sensor. Only required when the G5 has failed a periodic altimeter test. See Section 8.4.6.3 for more information.

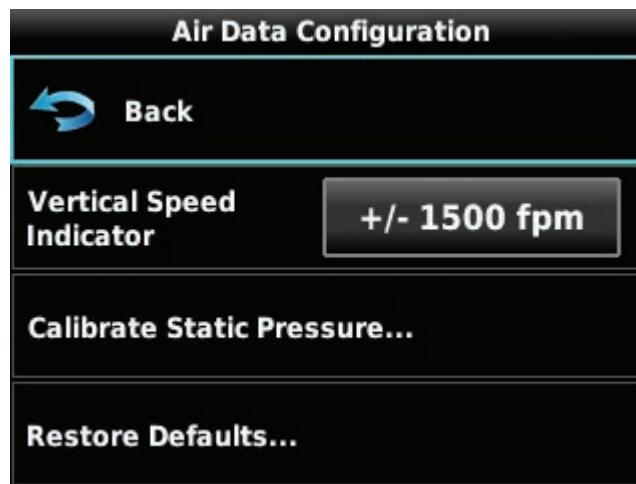

Figure 8-5 Air Data Configuration Page

8.4.4 Airspeed Configuration Page

This page allows for configuration of the reference speeds. The aircraft Vspeeds can be entered using the knob on the G5.

To clear a reference speed setting:

1. Highlight the desired reference speed setting.
2. Turn the knob counterclockwise until a blank field is displayed.

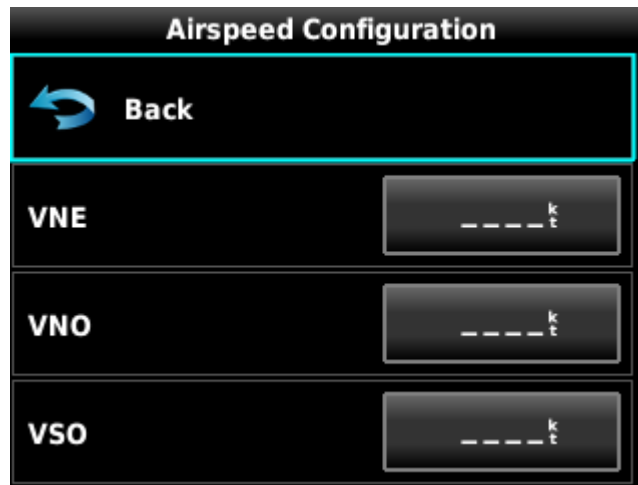

Figure 8-6 Airspeed Configuration Page

8.4.5 Magnetometer Configuration Page

The Magnetometer Configuration page is used to enable or disable the magnetometer function depending on whether an optional GMU 11 Magnetometer is connected to the G5.

Table 8-3 Magnetometer Configuration Settings

Configuration Setting	Description
Magnetometer	Select Disabled to disable the G5's optional magnetometer function. The Enabled option is intended for single standalone G5 installations that are connected to a GMU 11 Magnetometer.
Status	Indicates status of communication with GMU 11.
Orientation	Used to inform the G5 of the mounted orientation of a GMU 11 Magnetometer (optional). See Section 8.4.6.4 for detailed instructions.
Interference Test	Used to verify that no magnetic interference exists near the GMU 11 installation. See Section 8.4.6.5 for detailed instructions.
Calibrate Magnetometer	Used to calibrate the magnetometer in the mounted location/orientation. See Section 8.4.6.6 for detailed instructions.

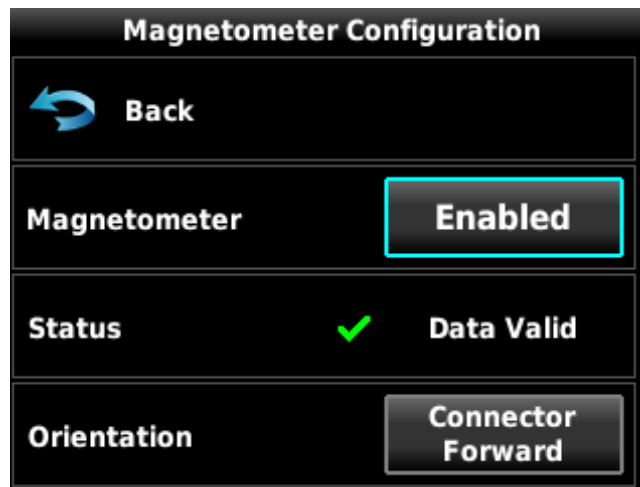

Figure 8-7 Magnetometer Configuration Page

8.4.6 G5 Post-Installation Calibration Procedures

After mechanical and electrical installation of the G5 has been completed, but before operation, a set of post-installation calibration procedures must be carried out. Table 8-4 describes the required and optional calibration procedures.

Table 8-4 Post-Installation Calibration Procedure Summary

Calibration Procedure	Procedure Name	Procedure Description	Installations Requiring Procedure
A	Pitch/Roll Offset Compensation	Level aircraft	Procedure A is required for all installations
B	Engine Run-Up Vibration Test	Validate vibration characteristics of installation	Procedure B is required for all installations
C	Air Data Static Pressure Calibration	Altitude re-calibration	Procedure C is only used when the G5 has failed a periodic altimeter test
D	Magnetometer Unit Orientation	Configure magnetometer installation orientation	Procedure D is required for all GMU 11 installations
E	Magnetometer Interference Test	Validate no magnetic interference with GMU 11 Magnetometer	<p>Procedure E is required for initial installation verification.</p> <p>This test should also be repeated to verify all subsequent electrical changes associated with devices within 10 feet of the magnetometer. Such changes include, but are not limited to, wiring, shielding or grounding changes to any light, strobe, beacon or other electrical device located near or in the same wing as the magnetometer. Likewise, this test should also be repeated to verify all subsequent changes to materials within 10 feet of the magnetometer. Such changes include, but are not limited to, addition, removal or modification of ferrous or electrically conductive materials located near or in the same wing as the magnetometer unit.</p> <p>Garmin recommends this test be performed at least once every 12 months.</p>
F	Magnetometer Calibration Procedure	Compass rose taxi maneuver	<p>Procedure F is required for all installations.</p> <p>This calibration must be performed after every Pitch/Roll Offset Compensation and following a removal or replacement of the GMU 11, or degaussing of the area near the GMU 11 location.</p>

8.4.6.1 Calibration Procedure A: Pitch/Roll Offset Compensation



NOTE

This procedure requires orienting the aircraft to normal flight attitude. This can be done by using jacks or placing wood blocks under the nose-wheel, for example. As another example, if the number of degrees ‘nose high’ the aircraft flies in straight and level cruise is known, a digital level can be used to orient the aircraft to normal flight attitude before the calibration.



NOTE

The G5 must be installed to be level in pitch/roll within 30.0° of the aircraft in-flight level cruise attitude. In-flight level cruise attitude is not necessarily the same as the level reference provided by the manufacturer (such as fuselage longerons).

1. Select the Attitude Configuration page.
2. Select Calibrate Pitch/Roll.
3. Ensure that aircraft and the unit comply with all on-screen instructions, then select Start.



Figure 8-8 Calibration Page

4. A progress screen will then be displayed. There is a 30 second countdown timer for the procedure that resets when the aircraft moves.
5. When the calibration is complete, a successful status message will be displayed along with the new pitch and roll offsets.



NOTE

The pilot may adjust the displayed pitch attitude in normal mode. The maximum amount of pitch display adjustment available in normal mode is ±5.0°. This feature should not be used to compensate for a non-conforming installation that does not meet the requirements of the pitch/roll offset compensation calibration procedure.



NOTE

In a G3X system, or a non-G3X system with multiple G5 units, if the pitch/roll offset procedure is performed for one unit, it should be performed on all other G3X AHRS units or G5 units before moving the aircraft.

8.4.6.2 Calibration Procedure B: Engine Run-Up Vibration Test



NOTE

Calibration Procedure B is required for all installations to validate the vibration characteristics of the installation.

Passing the Engine Run-Up Vibration test does not remove the requirement to rigidly mount the G5. The Engine Run-Up Vibration Test is intended to help discover mounting issues but successful completion of the test does not validate the mounting of the G5, and does not account for all possible vibration profiles that may be encountered during normal aircraft operation

1. Select the Attitude Configuration page.
2. Select Vibration Test.
3. Ensure the aircraft complies with all on-screen instructions, then select Start.

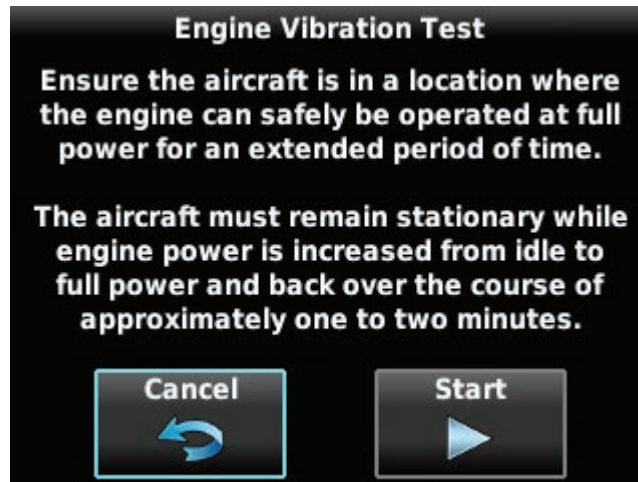

Figure 8-9 Vibration Test Page

4. Gradually increase engine power from idle to full power and back over the course of 1-2 minutes. A progress screen will be displayed showing the status of the test.
5. Select Done when the test has been completed. Passing results will be indicated by a green check mark and failures will be indicated by a red "X". If failures are indicated, repeat the test. If failures persist, the installation should be considered unreliable until the source of the vibration problem is identified and remedied. Record the out of range limit values for future reference.

The following are potential causes for failures of the engine run-up test:

- a) Excessive flexing of the G5 mechanical mounting with respect to airframe (see [Section 3.4.1](#) for applicable mounting requirements and instructions).
- b) Vibration or motion of the G5 caused by neighboring equipment and/or supports.
- c) Mounting of the G5 in a location that is subject to severe vibrations (e.g. close to an engine mount).
- d) Mounting screws and other hardware for G5 not firmly attached.
- e) Absence of recommended mounting supports.
- f) G5 connector not firmly attached to unit.
- g) Cabling leading to the G5 not firmly secured to a supporting structure.
- h) An engine/propeller combination that is significantly out of balance.



NOTE

In some aircraft, attempting the engine run-up test on a day with very strong and/or gusty winds may cause the test to occasionally fail. However, windy conditions should not be taken as evidence the test would pass in calm conditions; an actual pass is required before the installation can be considered adequate.

8.4.6.3 Calibration Procedure C: Air Data Static Pressure Calibration

The Air Data Configuration page has a selection for static pressure calibration. This procedure is used to perform an altimeter re-calibration. The altitude pressure sensor used in the G5 is very low drift and does not typically require re-calibration.



NOTE

This calibration is only used when the G5 fails a periodic altimeter test and should only rarely, if ever, be used.

The static pressure calibration requires the use of a pressure control system (test set) with an altitude accuracy of at least ± 5 feet at sea level and ± 20 feet at 30,000 feet. It is necessary to re-calibrate to sea level (0 feet), 10,000 feet, 20,000 feet, and optionally to 30,000 feet. The operator is allowed to finish the calibration at the end of the 20,000-foot calibration if the 30,000-foot calibration is not desired.



CAUTION

To avoid damaging the G5 pressure sensors, both the pitot and static ports must be connected to the test set.

1. Select the Air Data Configuration page.
2. Select Calibrate Static Pressure.
3. Ensure all on-screen instructions have been complied with, then select Start.

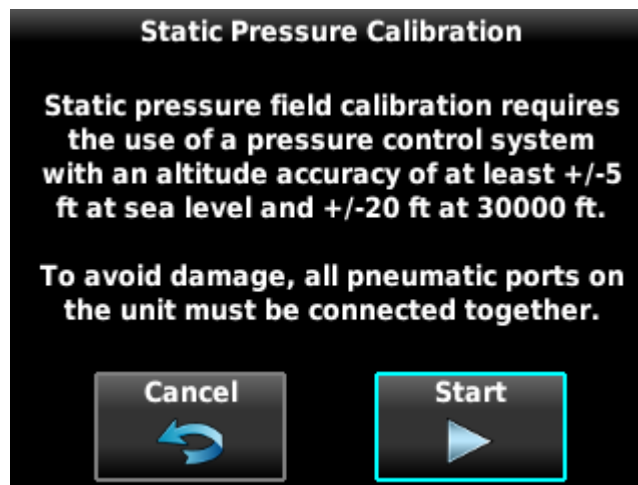

Figure 8-10 Static Pressure Calibration Page

4. At each calibration point the display will present a screen indicating the pressure altitude to set. Once the altitude is set, select Ready to calibrate this pressure.
5. During the calibration at each pressure, the pressure must be held constant for 30 seconds for the calibration step to be successful. The calibration may be cancelled at any point should the test setup require adjustment before repeating. A progress screen will be displayed showing the status of the test.
6. Select Done when the static pressure calibration is successfully completed.

8.4.6.4 Calibration Procedure D: Magnetometer Unit Orientation

1. Select the Magnetometer Configuration page.
2. Ensure the Status field displays Data Valid.
3. Select the Orientation of the GMU 11 in the installation using the on-screen instructions as a guide.

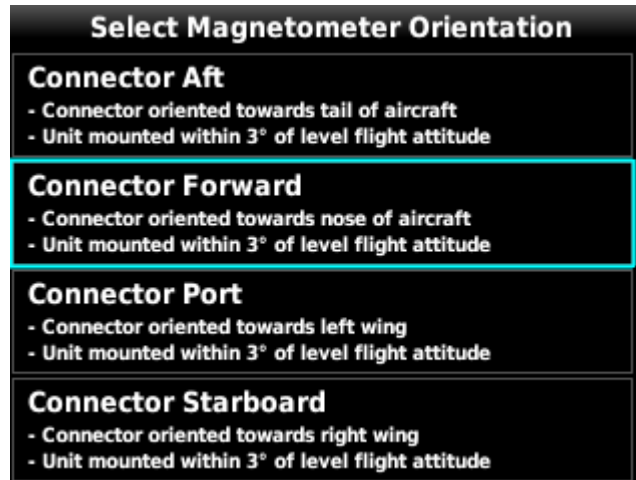

Figure 8-11 Select Magnetometer Orientation

4. Ensure the correct orientation is now displayed on the Magnetometer Configuration page.

8.4.6.5 Calibration Procedure E: Magnetometer Interference Test



NOTE

Calibration Procedure E is required for all installations that include a GMU 11 in order to validate the magnetic characteristics of the installation.

1. Select the Magnetometer Configuration page.
2. Select Interference Test.
3. Ensure the aircraft complies with all on-screen instructions, then select Next.

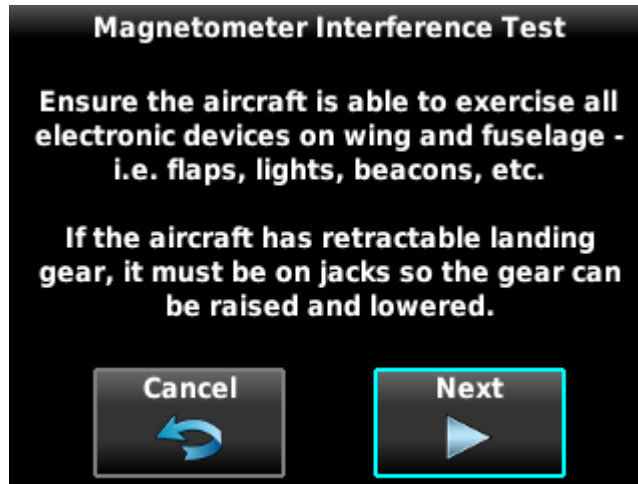

Figure 8-12 Magnetometer Interference Test

4. Ensure the aircraft has been properly prepared per the on-screen instructions. See Table 8-5 for a sample test sequence. Select Start to begin the test.



Figure 8-13 Magnetometer Interference Test

- The operator should carry out the actions called for in the prepared test sequence. During calibration, a real-time value is displayed that represents the current magnetic field strength as a percentage of the maximum limit.

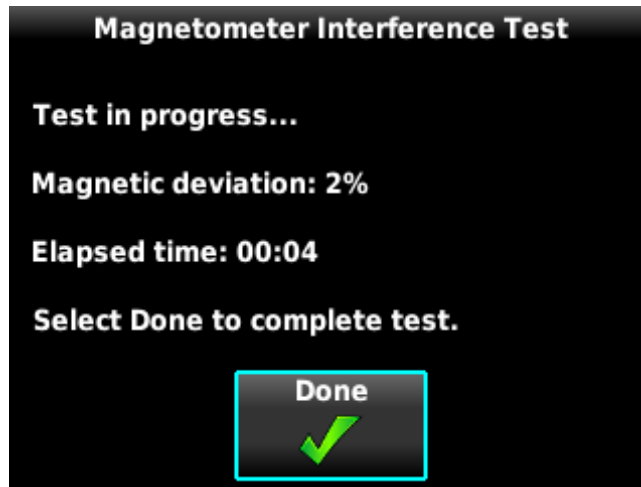

Figure 8-14 Magnetometer Interference Test In Progress



NOTE

It is important that all actions are carried out in the order and at the precise elapsed time as specified in the prepared test sequence.

- After completing the prepared test sequence, select Done. The test status will indicate whether the interference test passed or failed. The worst case magnetic deviation value will indicate the test margins. Values less than or equal to 100% constitute a pass and greater than 100% constitute a fail.

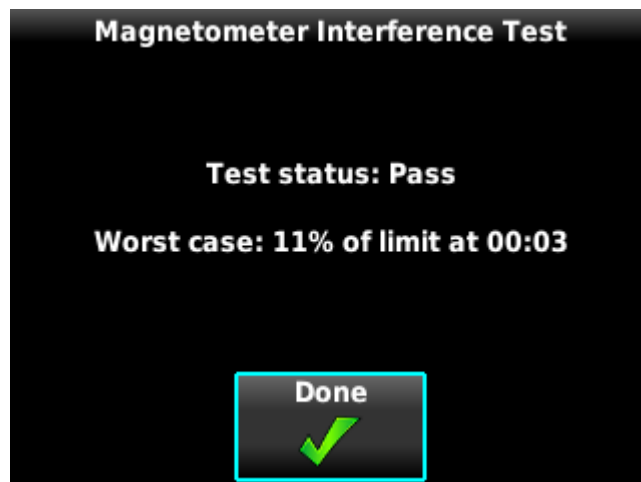

Figure 8-15 Magnetometer Interference Test Passed

Table 8-5 Magnetometer Interference Test Sequence Example

Elapsed Time Since Start of Test (min:sec)	Action
0:00	Test begins
0:10	Aileron full right
0:20	Aileron full left
0:30	Aileron level
0:40	Elevator up
0:50	Elevator down
1:00	Elevator level
1:20	Rudder left
1:40	Rudder right
1:50	Rudder center
2:00	Flaps down
2:10	Flaps up
2:20	Autopilot on
2:30	Autopilot off
2:40	Landing gear up
2:50	Landing gear down
3:00	Speed brake up
3:10	Speed brake down
3:20	Navigation lights on
3:30	Navigation lights off
3:40	Landing lights on
3:50	Landing lights off
4:00	Taxi lights on
4:10	Taxi lights off
4:20	Landing and taxi lights on
4:30	Landing and taxi lights off
4:40	Strobes on
4:50	Strobes off
5:00	Recognition lights on
5:10	Recognition lights off
5:20	Turn on all wing-tip lights simultaneously (this will typically include navigation lights, recognition lights, and strobe)
5:30	Turn off all wing-tip lights simultaneously
5:40	Beacon on
5:50	Beacon off
6:00	Pitot heat on
6:10	Pitot heat off
6:20	End of test

If the test fails, the installation should be considered unreliable until the source of magnetic interference is identified and remedied. The magnetometer interference test must be repeated until passed. When the magnetometer interference test fails, record the three greatest magnetic deviation values and their corresponding timestamps. A maximum deviation value greater than 100% of the total limit indicates a problem that must be resolved. Compare the corresponding timestamps with the prepared test sequence to identify which action produced the problem. Contact Garmin for assistance in resolving the problem.



NOTE

Two common reasons for a failed magnetometer interference test are:

- 1) New equipment is installed in close proximity to the GMU 11 Magnetometer.*
- 2) An existing or new electronic device has become grounded through the aircraft structure instead of through the proper ground wire in a twisted shielded pair.*

8.4.6.6 Calibration Procedure F: Magnetometer Calibration Procedure



NOTE

Calibration Procedures A, B, and C must be successfully completed before Calibration Procedure F.



NOTE

Calibration Procedure F must be carried out at a location that is determined to be free of magnetic disturbances, such as a compass rose. Attempting to carry out this maneuver on a typical ramp area will not yield a successful calibration. The accuracy of the magnetometer cannot be guaranteed if this calibration is not performed in a magnetically clean location.

Taxi the aircraft to a site that has been determined to be free of magnetic disturbances. Ensure there are no nearby magnetic materials on or near the perimeter of the site. If unavoidable, maneuver the aircraft to keep the magnetometer from passing within 20 feet (6.1 meters) of such objects. Additionally, ensure that vehicles or other aircraft are an adequate distance (40 feet [12.2 meters]) away from the aircraft during the calibration procedure.

At the site, align the aircraft to a heading of magnetic north ($\pm 5^\circ$). It is best to offset the aircraft position to the west of the north/south axis to provide space for the aircraft to turn clockwise around the site during the procedure as indicated in Figure 8-16.

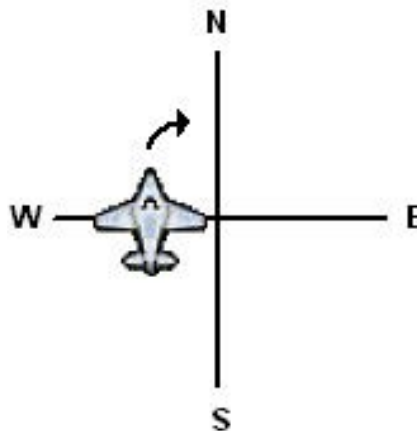

Figure 8-16 Aircraft Alignment

With the aircraft stationary, initiate the magnetometer calibration procedure as follows:

1. Select the Magnetometer Configuration page.
2. Select Calibrate Magnetometer.
3. Ensure that all on-screen instructions have been complied with, then select Next.



Figure 8-17 Magnetometer Calibration Page

4. Ensure that all on-screen instructions have been complied with, then select Next.

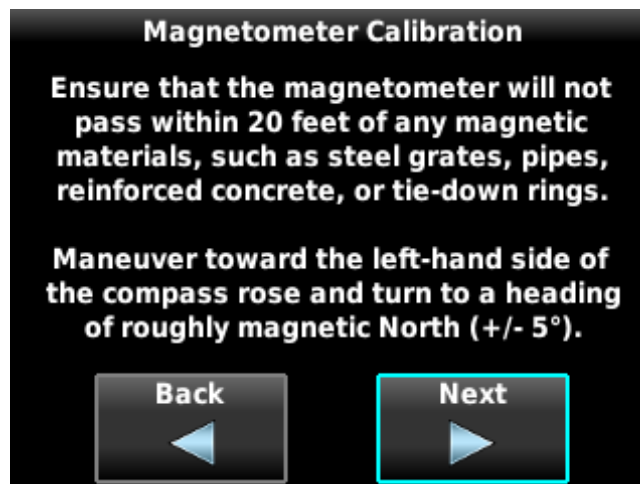

Figure 8-18 Magnetometer Calibration Page

5. Ensure that all on-screen instructions have been complied with, then select Start.

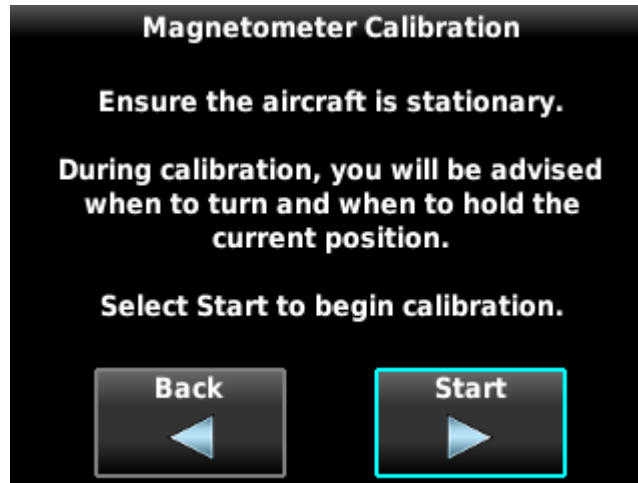

Figure 8-19 Magnetometer Calibration Page

6. Follow the on-screen instructions by holding the current aircraft position. During this time the magnetometer will be calibrating the magnetic environment of the installation. The dots at the end of the text will be removed as this step of the test progress.

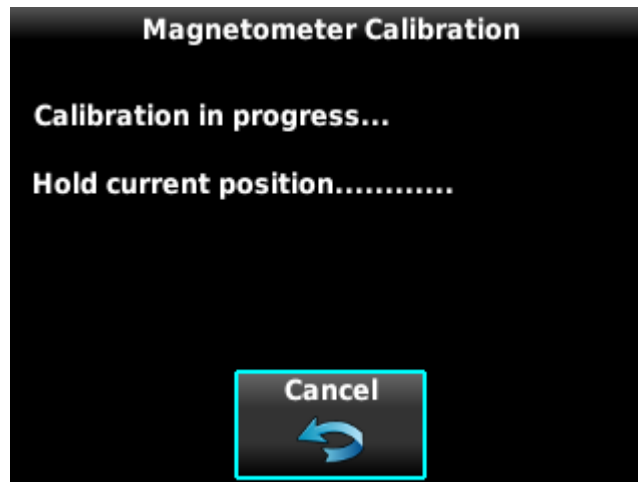

Figure 8-20 Magnetometer Calibration Page

7. After holding the starting position, continue following the on-screen instructions by slowly turning the aircraft to the right. The dots at the end of the text will be removed as the aircraft rotates 30°.
8. Continue following the on-screen instructions until the calibration is completed. The turn and hold procedure detailed above will repeat for a total of 12 cycles before the calibration is complete (resulting in the aircraft completing a full circle of rotation).
9. If the calibration is successful, a passing status message will be displayed. The calibration will abort if it cannot be successfully completed. Ensure all on-screen instruction are followed and repeat the test (if necessary) to obtain a successful calibration.

8.4.7 Flight Controls Configuration Page

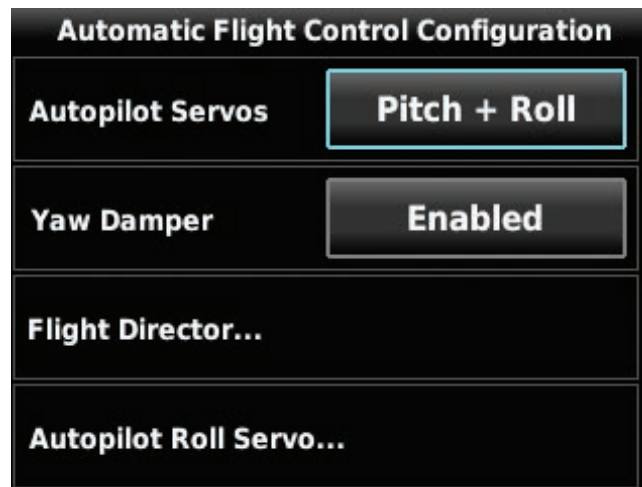

Figure 8-21 Flight Controls Configuration Page

8.4.7.1 General Autopilot Description

The GSA 28 based autopilot system is a fully integrated, high performance autopilot that can control up to three axes of an aircraft (refer to [Appendix E](#) for GSA 28 installation information). Each GSA 28 servo is also capable of managing the trim control for its axis. The following four subsections (roll, pitch, yaw, and trim) are provided to aid the pilot/installer in understanding/configuring the Garmin GSA 28 autopilot system.



NOTE

A GMC Mode Controller is required to use the G5 autopilot controls.

Roll Servo

All GSA 28 autopilot systems require a servo to control the roll axis of an aircraft. A single axis GSA 28 installation that controls only the roll axis is sometimes referred to as a “wing-leveler”.

The roll servo follows roll steering commands from the G5 so the airplane will hold a desired roll angle, follow a desired heading/track, or follow the lateral component of a flight plan.

During the flight test phase of the autopilot checkout, the roll servo aggressiveness will be adjusted to get the desired in-flight performance. The roll servo gain setting is used to set the aggressiveness of the roll servo. A larger number will cause the roll servo to more aggressively control the aircraft and a smaller number will cause the roll servo to less aggressively control the aircraft.

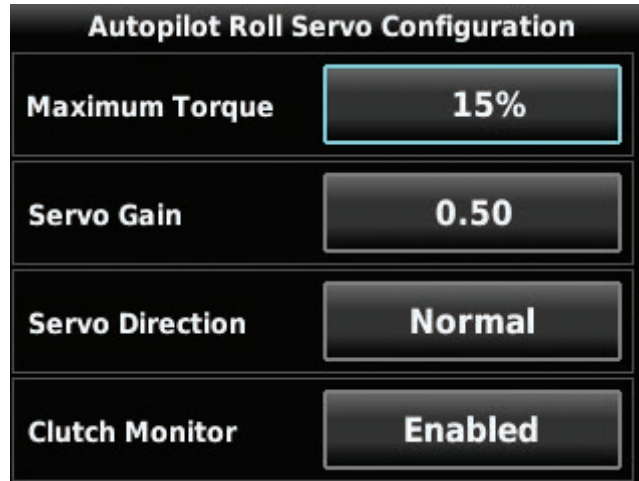

Figure 8-22 Roll Servo Configuration Page

Pitch Servo

Most GSA 28 autopilot systems consist of both a roll and pitch servo allowing for full 2-axis control of the aircraft.

The pitch servo follows vertical guidance commands from the G5 so the airplane will hold a desired pitch angle, vertical speed, airspeed, or altitude, or follow the vertical component of a flight plan.

Vertical control of the aircraft is all based on controlling the pitch angle with two additional sub-modes for vertical speed and airspeed. What this means is the basic pitch mode performance must be properly adjusted before changing settings that adjust the vertical speed and airspeed based modes.



NOTE

Ensure pitch mode functionality is properly adjusted before attempting to adjust vertical speed or airspeed mode performance.

During the flight test phase of the autopilot checkout, the pitch servo aggressiveness will be adjusted to get the desired in-flight performance. The pitch servo gain setting is used to set the aggressiveness of the pitch servo. A larger number will cause the pitch servo to more aggressively control the aircraft, and a smaller number will cause the pitch servo to less aggressively control the aircraft.



Figure 8-23 Pitch Servo Configuration Page

Yaw Damper

The GSA 28 autopilot system can be expanded to support a yaw damper. The yaw damper will control the rudder to compensate or remove aircraft body yaw (tail wagging). The yaw damper will also try to null the lateral acceleration (center the ball) over the long term. The ball centering portion of the yaw damper is not a replacement for proper rudder trim.



NOTE

Yaw damper functionality requires a GMC Mode Controller with a YD button.

During the flight test phase, the yaw damper is configured and set up after the basic two axis pitch and roll performance has been properly configured. This is done so the pilot can focus on properly adjusting the performance of each individual component of the autopilot system without trying to tune them all at once.



NOTE

Ensure basic autopilot functionality is properly adjusted before using the yaw damper.

During the flight test phase of the autopilot checkout, the yaw servo aggressiveness will be adjusted to get the desired in-flight performance. The yaw servo gain setting is used to set the aggressiveness of the yaw servo. A larger number will cause the yaw servo to more aggressively control the aircraft, and a smaller number will cause the yaw servo to less aggressively control the aircraft.



Figure 8-24 Yaw Damper Configuration Page

Trim Control

The GSA 28 autopilot servos can be used to control the trim system in an aircraft. When the autopilot is disengaged, the servos can adjust the trim speed based on the current aircraft airspeed. This allows the trim to run slower at high airspeeds and faster at low airspeeds. When the autopilot is engaged in the air, the servos can adjust the trim control to minimize the force on the primary controls. This helps ensure the aircraft will be properly trimmed when the autopilot is later disengaged.

During the flight test phase, the trim system is configured and set up after the primary autopilot performance has been properly configured. This is done so the pilot can focus on properly adjusting the performance of the primary autopilot system without having the autotrim functionality interfere.



NOTE

Ensure basic autopilot functionality is properly adjusted before enabling trim control for any servo.

8.4.7.2 On-Ground Initial Checkout



NOTE

The following post installation checkout must be followed after every completed installation. These steps should be followed when using a Garmin mounting kit or non-Garmin mounting parts to install the GSA 28.

After mounting the GSA 28, please complete the following steps before completing the first flight with the GSA 28.

1. Verify the flight controls can move from stop to stop without binding or interference. Check the GSA 28 output mechanism and added linkage do not come in contact with any part of the airframe while traveling through its full range of motion.
2. Verify the travel of the flight controls is being limited by the airplane's primary stops and not the secondary stops provided by the GSA 28 stop bracket.
3. Ensure the structural integrity of the mounting bracket is adequate for the application and well secured to the airframe. Bracket deflection caused by normal servo loading and aircraft acceleration/vibration should be minimal. Verify there are no cracks or sharp inside corners that could lead to fatigue failures.
4. Verify the fasteners used to mount the servo to the airframe are installed and have been tightened.
5. Make sure the AP DISC wire is correctly wired and tested.
6. If powering the servo through a "pullable" circuit breaker (recommended), ensure the circuit breaker is both accessible and easily identifiable to the pilot.
7. Repeat steps 1-6 for all GSA 28 servos in the aircraft.

8.4.7.3 On-Ground Setup

Servo Wiring Checkout

The first phase of setting up the autopilot system is to verify the proper wiring of the GSA 28 servos while on the ground.

1. If the installation is a 1-axis (roll only) autopilot, use the Flight Controls Configuration page to configure the autopilot servos for roll only.
2. If the installation is a 2-axis (pitch and roll) autopilot, use the Flight Controls Configuration page to configure the autopilot servos for pitch and roll.
3. If the installation is a 3-axis (pitch, roll, and yaw) autopilot, use the Flight Controls Configuration page to configure the autopilot servos for pitch and roll and enable the yaw damper.
4. Ensure the pitch, roll, and yaw servos are properly communicating by checking the Device Information page. Each device should have a green check mark next to it.

Device Information			
<input checked="" type="checkbox"/>	ROLL	GSA 28	3.20
<input checked="" type="checkbox"/>	PITCH	GSA 28	3.20
<input checked="" type="checkbox"/>	YD	GSA 28	3.20
<input checked="" type="checkbox"/>	GMC	GMC 305	2.00

Figure 8-25 Device Information Page

5. Select the Autopilot Roll Servo Configuration page and verify the proper trim activity with the servo connected to an auxiliary trim motor.

Autopilot Roll Servo Configuration	
Maximum Torque	15%
Servo Gain	0.50
Servo Direction	Normal
Clutch Monitor	Enabled

Figure 8-26 Autopilot Roll Servo Configuration Page

- a) Center the aileron trim switch to input no trim command. Verify the aileron trim switch is not moving. Verify the roll servo is properly indicating no trim activity.
 - b) Use the aileron trim switch to input a roll right trim command. Verify the aileron trim switch properly moves for roll right trim. Verify the roll servo is properly indicating roll right trim activity.
 - c) Use the aileron trim switch to input a roll left trim command. Verify the aileron trim switch properly moves for roll left trim. Verify the roll servo is properly indicating roll left trim activity.
 - d) If the aileron trim response is reversed, select Reverse for the Trim Motor Direction, then repeat all of step 5.
6. Select the Autopilot Pitch Servo Configuration page and verify the proper trim activity with the servo connected to an auxiliary trim motor.



Figure 8-27 Autopilot Pitch Servo Configuration Page

- a) Center the elevator trim switch to input no trim command. Verify the elevator trim switch is not moving. Verify the pitch servo is properly indicating no trim activity.
- b) Use the elevator trim switch to input a nose up trim command. Verify the elevator trim switch properly moves for nose up trim. Verify the pitch servo is properly indicating nose up trim activity.
- c) Use the elevator trim switch to input a nose down trim command. Verify the elevator trim switch properly moves for nose down trim. Verify the pitch servo is properly indicating nose down trim activity.
- d) If the elevator trim response is reversed, select Reverse for the Trim Motor Direction, then repeat all of step 6.

7. Select the Yaw Damper Configuration page and verify the proper trim activity with the servo connected to an auxiliary trim motor.



Figure 8-28 Yaw Damper Configuration Page

- a) Center the aircraft rudder trim switch to input no trim command. Verify the rudder trim switch is not moving. Verify the yaw servo is properly indicating no trim activity.
 - b) Use the rudder trim switch to input a yaw right trim command. Verify the rudder trim switch properly moves for yaw right trim. Verify the yaw servo is properly indicating yaw right trim activity.
 - c) Use the rudder trim switch to input a yaw left trim command. Verify the rudder trim switch properly moves for yaw left trim. Verify the yaw servo is properly indicating yaw left trim activity.
 - d) If the rudder trim response is reversed, select Reverse for the Trim Motor Direction, then repeat all of step 7.
8. Select the Autopilot Roll Servo Configuration page to configure the servo direction.
 - a) With the Servo Direction set to Normal, the servo arm should move clockwise to cause a bank left aileron movement and the servo arm should move counterclockwise to cause a bank right aileron movement.
 - b) With the Servo Direction set to Reverse, the servo arm should move clockwise to cause a bank right aileron movement and the servo arm should move counterclockwise to cause a bank left aileron movement.
 9. Select the Autopilot Pitch Servo Configuration page to configure the servo direction.
 - a) With the Servo Direction set to Normal, the servo arm should move clockwise to cause a nose down elevator movement and the servo arm should move counterclockwise to cause a nose up elevator movement.
 - b) With the Servo Direction set to Reverse, the servo arm should move clockwise to cause a nose up elevator movement and the servo arm should move counterclockwise to cause a nose down elevator movement.

10. Select the Yaw Damper Configuration page to configure the servo direction.
 - a) With the Servo Direction set to Normal, the servo arm should move clockwise to cause a nose left rudder movement and servo arm should move counterclockwise to cause a nose right rudder movement.
 - b) With the Servo Direction set to Reverse, the servo arm should move clockwise to cause a nose right rudder movement and the servo arm should move counterclockwise to cause a nose left rudder movement.
11. Set the Trim Motor Control to Disabled using the Autopilot Roll Servo, Autopilot Pitch Servo, and Yaw Damper Configuration pages as applicable.

**NOTE**

Initial autopilot tuning is done with the trim control disabled to avoid the autotrim function from interfering with the initial autopilot tuning.

- a) By disabling the trim motor control, this will disable autotrim and airspeed scheduled trim, but the pilot can still control trim in the aircraft using the normal manual electric trim inputs. Autotrim and airspeed scheduled trim will be setup later in the autopilot setup procedure.
12. The proper minimum and maximum airspeed limits for the pitch servo can be set in the Autopilot Pitch Servo Configuration page. The pitch servo will lower or raise the nose of the aircraft to keep the aircraft within these airspeed limits.
 - a) The minimum airspeed limit should be set above the stall speed of the aircraft with some margin.
 - b) The maximum airspeed limit should be set below the never exceed speed of the aircraft with some margin.

8.4.7.4 On-Ground Autopilot Setup

The next phase of setting up the Garmin autopilot system is to verify the proper functionality of the autopilot system on the ground in normal mode. This phase of the checkout requires a valid ground track and pitch output from the G5. This means the post installation procedures must have already been completed on the G5 before performing the on-ground autopilot normal mode checkout.



NOTE

If the installation does not include a magnetometer, HDG mode will be replaced by TRK mode. All other instructions are applicable to either type of installation.

1. Leave the autopilot disengaged and verify the controls can be manipulated smoothly with no control system binding.
2. Engage the autopilot in HDG/PIT mode and command a nose down, left bank.
 - a) Press the AP button on the GMC Mode Controller.
 - b) Press the HDG button on the GMC Mode Controller.
 - c) Push the knob on the G5 to access the menu.
 - d) Select Track from the menu on the G5.
 - e) Push and hold the knob on the G5 to center the HDG bug.
 - f) Turn the knob on the G5 counterclockwise to command a left turn.
 - g) Turn the wheel on the GMC Mode Controller down to command a pitch downward.
3. Verify the stick properly moves toward the nose and toward the left wing smoothly with no control system binding.
4. Engage the autopilot in HDG/PIT mode and command a nose down, right bank.
 - a) Press the AP button on the GMC Mode Controller.
 - b) Press the HDG button on the GMC Mode Controller.
 - c) Push the knob on the G5 to access the menu.
 - d) Select Track from the menu on the G5.
 - e) Push and hold the knob on the G5 to center the HDG bug.
 - f) Turn the knob on the G5 clockwise to command a right turn.
 - g) Turn the wheel on the GMC Mode Controller down to command a pitch downward.
5. Verify the stick properly moves toward the nose and toward the right wing smoothly with no control system binding.

6. Engage the autopilot in HDG/PIT mode and command a nose up, right bank.
 - a) Press the AP button on the GMC Mode Controller.
 - b) Press the HDG button on the GMC Mode Controller.
 - c) Push the knob on the G5 to access the menu.
 - d) Select Track from the menu on the G5.
 - e) Push and hold the knob on the G5 to center the HDG bug.
 - f) Turn the knob on the G5 clockwise to command a right turn.
 - g) Turn the wheel on the GMC Mode Controller up to command a pitch upwards.
7. Verify the stick properly moves toward the tail and toward the right wing smoothly with no control system binding.
8. Engage the autopilot in HDG/PIT mode and command a nose up, left bank.
 - a) Press the AP button on the GMC Mode Controller.
 - b) Press the HDG button on the GMC Mode Controller.
 - c) Push the knob on the G5 to access the menu.
 - d) Select Track from the menu on the G5.
 - e) Push and hold the knob on the G5 to center the HDG bug.
 - f) Turn the knob on the G5 counterclockwise to command a left turn.
 - g) Turn the wheel on the GMC Mode Controller up to command a pitch upwards.
9. Verify the stick properly moves toward the tail and toward the left wing smoothly with no control system binding.
10. If the stick position does not move in the correct direction, correct the roll and pitch servo directions documented in the Servo Wiring Checkout.
11. Engage the autopilot and verify it can be overpowered in both the pitch and roll axes. If the autopilot cannot be overpowered, use the Autopilot Roll Servo and Autopilot Pitch Servo Configuration pages to reduce the Maximum Torque setting for the associated servo.
12. Engage the autopilot and verify it properly disconnects with a short press and release of the CWS/DISCONNECT button.

8.4.7.5 On-Ground Yaw Damper Setup

The next phase of setting up the Garmin autopilot system is to verify the proper functionality of the yaw damper system on the ground in normal mode. This phase of the checkout requires a valid output from the G5. This means the post installation procedures must have been completed on the G5 before performing the on-ground autopilot normal mode checkout.

1. Leave the yaw damper disengaged and verify the rudder pedals can be manipulated smoothly with no control system binding.
2. Engage the autopilot in YD mode by pressing the YD button on the GMC Mode Controller.
3. Verify the rudder properly moves to the correct direction by standing by the tail of the aircraft, facing the vertical stabilizer, and pushing on the fuselage. The rudder should move AWAY from you (the rudder should move in the same direction the rear fuselage is moving):
 - a) If the rudder does not move the correct direction, correct the yaw servo direction documented in the Servo Wiring Checkout.
4. Engage the yaw damper and verify it can be overpowered in the yaw axis using rudder pedal inputs. If the autopilot cannot be overpowered, use the Yaw Damper Configuration page to reduce the Maximum Torque setting for the yaw damper servo.
5. The CWS/DISCONNECT input can optionally be connected to the Yaw Damper. If this connection was made, engage the yaw damper and verify it properly disconnects with a short press and release of the CWS/DISCONNECT button.

8.4.7.6 In-Air Autopilot Setup

The next phase of setting up the Garmin autopilot system is to verify and tune the proper functionality of the autopilot system while airborne. Refer to [Section 8.4.7.1](#) for general autopilot use and functionality.



WARNING

This stage of the flight test involves allowing the GSA 28 autopilot servos to manipulate the flight control surfaces of the aircraft. Extreme caution should be used during the initial engagement of the autopilot system. The pilot should always have easy access to the autopilot disconnect button to disconnect the autopilot and take control of the aircraft at anytime.

At a minimum, please follow the following safety guidelines before the initial autopilot engagement:

- Quick access to autopilot disconnect
- Safe altitude above and away from all terrain and obstacles
- No air traffic in the area
- Safe airspeed below maneuvering speed (VA)



NOTE

If desired, in the following procedures, the expert configurations can be accessed from the Autopilot Roll Servo, Autopilot Pitch Servo, and Yaw Damper Configuration pages.

Roll Servo

1. Use the Setup page in normal mode to adjust the roll servo gain setting.
 - a) Engage the autopilot in ROL/PIT mode with the aircraft approximately level.
 - i. Press the AP button on the GMC Mode Controller to engage the AP.
 - ii. Press the YD button on the GMC Mode Controller to disengage the YD.
 - b) Press the knob of the G5 to access the menu.
 - c) Select Setup from the menu.
 - d) Select the Autopilot Roll Servo page.
 - e) Select the Servo Gain entry.
 - f) Adjust the servo gain so the aircraft properly responds to the roll guidance from the flight director.
 - i. Overpower the autopilot to fly away from the current flight director commanded roll.
 - ii. Release the controls and monitor the autopilot response and closure back to the commanded roll.
 - iii. Set the servo gain higher to make the autopilot more aggressive.
 - iv. Set the servo gain lower to make the autopilot less aggressive.
2. The roll servo has additional expert configurations that can be adjusted to achieve the desired lateral mode performance. These settings are detailed in [Table 8-7](#) and should only be adjusted after studying the descriptions to properly understand their effect on the roll servo.

Pitch Servo

1. Use the Setup page in normal mode to adjust the pitch servo gain setting. It is important to ensure proper autopilot response in PIT mode before proceeding to adjust other autopilot pitch axis gains and modes (including ALT and VS modes).
 - a) Engage the autopilot in ROL/PIT mode with the aircraft approximately level.
 - i. Press the AP button on the GMC Mode Controller to engage the AP.
 - ii. Press the YD button on the GMC Mode Controller to disengage the YD.
 - b) Press the knob on the G5 to access the menu.
 - c) Select Setup from the menu.
 - d) Select the Autopilot Pitch Servo page.
 - e) Select the Servo Gain entry.
 - f) Adjust the servo gain so the aircraft properly responds to the pitch guidance from the flight director.
 - i. Overpower the autopilot to fly away from the current flight director commanded pitch.
 - ii. Release the controls and monitor the autopilot response and closure back to the commanded pitch.
 - iii. Set the servo gain higher to make the autopilot more aggressive.
 - iv. Set the servo gain lower to make the autopilot less aggressive.

2. The pitch servo has additional expert configurations that can be adjusted to achieve the desired vertical mode performance. These settings are detailed in [Table 8-8](#) and should only be adjusted after studying the descriptions to properly understand their effect on the pitch servo.

Pitch Servo Gain

The pitch servo gain settings should be configured only after the pitch/roll servo max torque and servo gains have been set per the preceding pages.

The minimum maximum airspeed limit entries set the limits of the autopilot vertical authority. The autopilot will limit the pitch control to stay within these airspeed limits.

The vertical speed gain entry is one of the most important gains in the system since it controls the behavior of the VNAV, ALT, and VS modes and also largely determines how well the plane flies approaches with vertical guidance.

The vertical speed gain is adjusted in a very similar manner to the pitch servo gain. Engage the autopilot in ROL/VS mode in level flight (vertical speed approximately zero).

Adjust the vertical speed gain so the aircraft properly responds to the VS guidance from the flight director.

1. Overpower the autopilot to fly away from the current flight director commanded vertical speed.
2. Release the controls and monitor the autopilot response and closure back to the commanded vertical speed.
3. Set the vertical speed gain higher to make the autopilot more aggressive if it feels “lazy” or not as responsive as desired.
4. Set the vertical speed gain lower to make the autopilot less aggressive if the control is too “harsh” or more responsive than desired.

The vertical acceleration gain can often be left set at 1.00, but can be used to improve altitude captures when climbing or descending in VS or VNAV mode.

1. Climb to an altitude target in VS mode and note the altitude capture.
2. Set the vertical acceleration gain higher if the aircraft objectionably overshoots the altitude target before leveling off at the correct altitude.
3. Set the vertical acceleration gain lower if the aircraft objectionably undershoots the altitude target before leveling off at the correct altitude.

Similar to the vertical speed gain, the airspeed gain can be used to improve airspeed hold performance when needed.

Pitch Gain has advanced and expert configurations that can be adjusted to achieve the desired performance. These settings are detailed in [Table 8-8](#) and should only be adjusted after studying the descriptions to properly understand their effect on pitch gain.

Yaw Damper Setup

The next phase of setting up the Garmin yaw damper system is to verify and tune the proper functionality of the yaw damper system in the air.



WARNING

This stage of the flight test involves allowing the GSA 28 autopilot servos to manipulate the flight control surfaces of the aircraft. Extreme caution should be used during the initial engagement of the autopilot system. The pilot should always have easy access to the autopilot disconnect button to disconnect the autopilot and take control of the aircraft at anytime.

At a minimum, please follow the following safety guidelines before the initial autopilot engagement:

- Quick access to autopilot disconnect
 - Safe altitude above and away from all terrain and obstacles
 - No air traffic in the area
 - Safe airspeed below maneuvering speed (VA)
1. Use the Setup page in normal mode to adjust the yaw damper gain setting.
 - a) Press the knob on the G5 to access the menu.
 - b) Select Setup from the menu.
 - c) Select the Yaw Damper page.
 - d) Select the Servo Gain entry.
 - e) Adjust the servo gain so the aircraft properly responds to the yaw body rates (tail wagging).
 - i. Engage the autopilot in LVL mode with the aircraft approximately level.
 - ii. Press the LVL button on the GMC Mode Controller to engage the AP in LVL mode.
 - iii. Press the YD button on the GMC Mode Controller to disengage the YD.
 - iv. Fly a yaw doublet and engage the YD as the ball swings through the center.
 1. Use the right foot rudder to swing the ball left.
 2. Use the left foot rudder to swing ball back right.
 3. Engage the yaw damper by pressing the YD button on the GMC Mode Controller as the ball swings through the center.
 4. Set the servo gain so the established yaw body rate from the yaw doublet is properly dampened out.
 - a) Set the servo gain higher to make the yaw damper more aggressive (if needed).
 - b) Set the servo gain lower to make the yaw damper less aggressive (if needed).
 2. The yaw servo has additional expert configurations that can be adjusted to achieve the desired yaw damping performance. These settings are detailed in [Table 8-9](#) and should only be adjusted after studying the descriptions to properly understand their effect on the yaw servo.

8.4.7.7 On-Ground Trim System Setup

After setting up and testing the GSA 28 based autopilot and yaw damper systems, the pilot can configure the trim system.

1. Set the Trim Motor Control to Enabled using the Autopilot Roll Servo, Autopilot Pitch Servo, and Yaw Damper Configuration pages for all servos that are connected to auxiliary trim motors.
 - a) The recommended setting for the Fastest Trim Motor Speed is 100% (this value will be adjusted during the in-air setup).
 - b) The recommended setting for the Slowest Trim Motor Speed is 25% (this value will be adjusted during the in-air setup).



NOTE

The Maximum Trim Run Time entry allows optional configuration of a time limit for use with a manual electric trim. When the manual trim input switch is pressed, the electric trim motor will stop running after the time limit expires, and will not run again until the trim input switch is released and pressed again. This can help prevent "trim runaway" caused by a stuck trim input switch. If the maximum trim motor run time is not set, the electric trim motor will run indefinitely as long as the manual trim input switch is held. Trim run time has no effect on auto trim.

2. Return to the Flight Controls Configuration page to set the airspeed thresholds for the fastest and slowest trim movement.
 - a) The recommended setting for the Trim Low Airspeed Threshold is the airspeed typically used for cruise flight.
 - b) The recommended setting for the Trim High Airspeed Threshold is the airspeed typically used to fly the normal aircraft landing pattern.
3. Re-verify proper trim movement described in [Section 8.4.7.3](#).

8.4.7.8 In-air Trim System Setup

The next phase of setting up the GSA 28 based trim control system is to verify and set the proper functionality of the trim system in the air. Refer to [Section 8.4.7.1](#) for general autopilot use and functionality.



WARNING

This stage of the flight test involves allowing the GSA 28 autopilot servos to manipulate the flight control surfaces of the aircraft. Extreme caution should be used during this phase of the flight test. The pilot should always have easy access to the autopilot disconnect button to disconnect the autopilot and take control of the aircraft at anytime.

At a minimum, please follow the following safety guidelines before the initial autopilot engagement:

- Quick access to autopilot disconnect
 - Safe altitude above and away from all terrain and obstacles
 - No air traffic in the area
 - Safe airspeed below maneuvering speed (VA)
1. Use the Setup page in normal mode to adjust the trim motor speed to get the desired manual electric trim response.
 - a) Press the knob on the G5 to access the menu.
 - b) Select Setup from the menu.
 - c) Note the low and high airspeed threshold settings on this page.
 - d) Select the Autopilot Roll Servo, Autopilot Pitch Servo, or Yaw Damper pages as applicable.
 - e) Adjust the trim motor speeds at the two airspeed thresholds to get a desirable trim response.
 - i. Trim aircraft using manual electric trim inputs
 - ii. Trim response should not be overly slow
 - iii. Trim response should not be overly fast

8.4.7.9 Autopilot Configuration Options

The installer needs to make the following autopilot configuration selections when setting up the GSA 28 based autopilot system.

Flight Controls Configuration Page

These selections are made in configuration mode using the Flight Controls page.



Figure 8-29 Automatic Flight Control Configuration Page

Table 8-6 Flight Control Configuration Settings

Configuration Setting	Description
Trim Low Airspeed Threshold	The GSA 28 servos are capable of airspeed scheduling the aircraft's manual electric trim. The Trim Low Airspeed Threshold setting is the airspeed at which the trim motor will be moved at its fastest setting. This should be the lower of the two airspeeds. The recommended setting for the Trim Low Airspeed Threshold is the airspeed typically used for cruise flight.
Trim High Airspeed Threshold	The GSA 28 servos are capable of airspeed scheduling the aircraft's manual electric trim. The Trim High Airspeed Threshold setting is the airspeed at which the trim motor will be moved at its slowest setting. This should be the higher of the two airspeeds. The recommended setting for the Trim High Airspeed Threshold is the airspeed typically used to fly the normal aircraft landing pattern.

Table 8-6 Flight Control Configuration Settings

Configuration Setting	Description
Control Wheel Steering	<p>The CWS/DISCONNECT discrete input to the GSA 28 servos is connected to a momentary push button which can function either as a dedicated Autopilot Disconnect (AP DISC) button, or as a combined Autopilot Disconnect / Control Wheel Steering (AP/CWS) button.</p> <p>Regardless of configuration, a short press and release of the AP DISC or AP/CWS button will disengage the autopilot if it is engaged.</p> <p>If Control Wheel Steering is enabled, pressing and holding the AP/CWS button places the autopilot into CWS mode. In CWS mode, the servos are temporarily disengaged, allowing hand-flying of the aircraft to a new aircraft attitude while the AP/CWS button is held. When the AP/CWS button is released, the autopilot exits CWS mode and the flight director synchronizes to the current aircraft attitude (if applicable for the current flight director mode).</p> <p>If Control Wheel Steering is disabled, CWS is not supported and the AP button serves as a dedicated AP DISC button only. The AP DISC button will disconnect the autopilot any time it is pressed, regardless of how long it is held.</p>
Engage AP Via CWS Input	<p>If Control Wheel Steering is enabled, the AP/CWS button can optionally be configured to engage the autopilot when pressed and held.</p> <p>If Engage AP Via CWS Input is enabled, the autopilot will automatically engage when the AP/CWS button is pressed and held.</p> <p>If Engage AP Via CWS Input is disabled, pressing the AP/CWS button while the autopilot is not engaged has no effect. In this state, the autopilot can only be engaged using the GMC Mode Controller AP button.</p>
AFCS Setup Page	<p>Controls access to the Automatic Flight Control System Setup page in normal mode. Leave this item set to Enabled unless specifically required for the installation.</p>

Roll Servo Configuration Page

The installer needs to make the following roll servo configuration selections when setting up the GSA 28 based autopilot system. All selections are available in configuration mode using the Autopilot Roll Servo Configuration page. Selections available in the normal mode Setup menu are noted with an asterisk in Table 8-7.

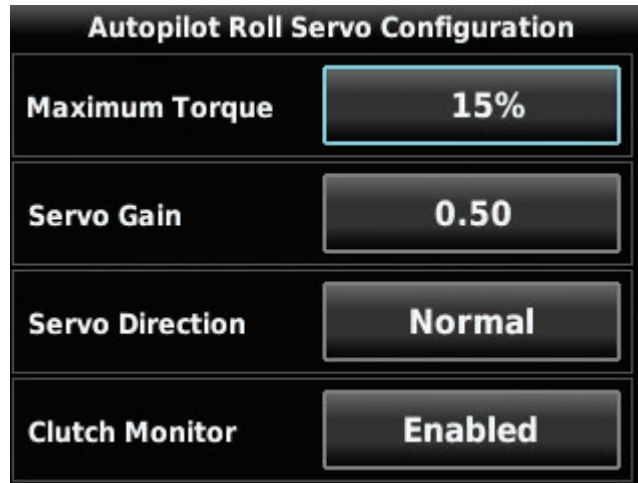

Figure 8-30 Automatic Roll Servo Configuration Page

Table 8-7 Autopilot Roll Servo Configuration Settings

Configuration Setting	Description
Maximum Torque*	The GSA 28 roll servo has a configurable maximum torque setting. This determines how much torque the servo will output before the electronic slip clutch begins to slip. The Maximum Torque setting should be set high enough to not slip during in-flight air loading, but low enough for the pilot to override the autopilot if required. The Maximum Torque setting can be adjusted from 15% to 100% in 5% steps.
Servo Gain*	The GSA 28 roll servo has a configurable servo gain setting. This determines how aggressively the roll servo will move the aileron surfaces. The Servo Gain should be set high enough to properly fly the desired roll, heading, and track, but low enough to avoid being overly aggressive in the aileron movements. The servo gain setting can be adjusted from 0.00 to 10.00 in steps of 0.05.

*Available in normal mode

Table 8-7 Autopilot Roll Servo Configuration Settings

Configuration Setting	Description
Servo Direction	<p>The GSA 28 roll servo has a configurable servo direction.</p> <p>The Servo Direction should be set to Normal if a clockwise movement of the servo arm causes a bank left aileron movement.</p> <p>The Servo Direction should be set to Reverse if a counterclockwise movement of the servo arm causes a bank left aileron movement.</p> <p>After selecting the proper servo direction, the installer should engage the autopilot system in normal mode and verify proper aileron response by using HDG/TRK mode and rotating the track bug to the left and to the right of the current track.</p>
Clutch Monitor	<p>The GSA 28 roll servo has the ability to monitor itself for a stuck clutch situation. If the servo has a large amount of side loading (typically due to a capstan installation), this can occasionally lead to invalid stuck clutch failures.</p> <p>The Clutch Monitor should be enabled for all control arm installations.</p> <p>The Clutch Monitor can be disabled for capstan installations with larger side loads to prevent invalid stuck clutch failures.</p>
Trim Motor Control	<p>The GSA 28 roll servo has the ability to control an auxiliary roll trim motor.</p> <p>The Trim Motor Control should be enabled if the GSA 28 roll servo is connected to an auxiliary trim motor.</p> <p>The Trim Motor Control should be disabled if the GSA 28 roll servo is not connected to an auxiliary trim motor.</p>
Trim Motor Direction	<p>The GSA 28 roll servo has a configurable trim motor direction. Select the Normal or Reversed setting depending on which is required for the proper trim motor movement when using the aircraft trim motor switches on the ground with the autopilot disengaged (servos powered).</p>
Trim Low Airspeed Thresh	<p>This setting specifies the airspeed below which the trim motor is always run at the Fastest Trim Motor Speed specified below.</p>
Trim High Airspeed Thresh	<p>This setting specifies the airspeed above which the trim motor is always run at the Slowest Trim Motor Speed specified below.</p>
Fastest Trim Motor Speed	<p>The GSA 28 roll servo will control the aileron trim on the aircraft.</p> <p>The Fastest Trim Motor Speed is the speed at which the roll servo will run the auxiliary trim motor when at or below the Trim Low Airspeed Thresh airspeed. Expressed as a percentage of the maximum auxiliary trim motor speed. The Fastest Trim Motor Speed can be adjusted from 5% to 100% in 5% steps.</p>
Slowest Trim Motor Speed	<p>The GSA 28 roll servo will control the aileron trim on the aircraft.</p> <p>The Slowest Trim Motor Speed is the speed at which the roll servo will run the auxiliary trim motor when at or above the Trim High Airspeed Thresh airspeed. Expressed as a percentage of the maximum auxiliary trim motor speed. The Slowest Trim Motor Speed can be adjusted from 5% to 100% in 5% steps.</p>

*Available in normal mode

Table 8-7 Autopilot Roll Servo Configuration Settings

Configuration Setting	Description
Slowest Auto Trim Motor Speed (expert configuration)	<p>The GSA 28 roll servo has the ability to drive the auxiliary trim motor at various speeds.</p> <p>The Slowest Auto Trim Motor Speed should be set so the auxiliary trim motor will move as slowly as possible. The slowest possible movement will ensure there is no noticeable aircraft response when the auxiliary trim motor is run during autotrim.</p> <p>The Slowest Auto Trim Motor Speed can be adjusted from 5% to 100% in 5% steps.</p>
Maximum Trim Run Time	<p>The GSA 28 servos can limit the maximum continuous run time of the trim motor. This can be used to help prevent the potential for a trim runaway situation.</p> <p>The Maximum Trim Run Time Limit is the maximum amount of time the trim servo will be run continuously when a manual electric trim input is detected. If the maximum time is exceeded, the pilot will need to release the Manual Electric Trim (MET) control and then reassert it to continue running trim.</p>
Fine Adjust Amount (expert configuration)	<p>The GSA 28 roll servo is capable of making very small adjustments to fine tune the aileron position. The Fine Adjust Amount is the amount in which these adjustments are made. Use the Fine Adjust Amount and Fine Adjust Time to correct very small oscillations in the aircraft.</p> <p>Fine Adjust Amount is an expert configuration setting, and should generally be not be changed by the installer. The default value is 0.</p>
Fine Adjust Time (expert configuration)	<p>The GSA 28 roll servo is capable of making very small adjustments to fine tune the aileron position. The Fine Adjust Time is the rate at which these adjustments are made. Use the Fine Adjust Amount and Fine Adjust Time to correct very small oscillations in the aircraft.</p> <p>Fine Adjust Time is an expert configuration setting, and should generally be not be changed by the installer. The default value is 0.20.</p>

*Available in normal mode

Pitch Servo Configuration Page

The installer needs to make the following pitch servo configuration selections when setting up the GSA 28 based autopilot system. All selections are available in configuration mode using the Autopilot Pitch Servo page. Selections available in the normal mode Setup menu are noted with an asterisk in Table 8-8.



Figure 8-31 Automatic Pitch Servo Configuration Page

Table 8-8 Autopilot Pitch Servo Configuration Settings

Configuration Setting	Description
Maximum Torque*	<p>The GSA 28 pitch servo has a configurable maximum torque setting. This determines how much torque the servo will output before the electronic slip clutch begins to slip.</p> <p>The Maximum Torque setting should be set high enough to not slip during in-flight air loading, but low enough for the pilot to override the autopilot if required.</p> <p>The Maximum Torque setting can be adjusted from 15% to 100% in 5% steps.</p>
Servo Gain*	<p>The GSA 28 pitch servo has a configurable servo gain setting. This determines how aggressively the pitch servo will move the elevator surfaces.</p> <p>The Servo Gain should be set high enough to properly fly the desired pitch, vertical speed, and altitude, but low enough to avoid being overly aggressive in the elevator movements.</p> <p>The servo gain setting can be adjusted from 0.00 to 10.00 in steps of 0.05.</p>
Servo Direction	<p>The GSA 28 pitch servo has a configurable servo direction.</p> <p>The Servo Direction should be set to Normal if a clockwise movement of the servo arm causes a nose down elevator movement.</p> <p>The Servo Direction should be set to Reverse if a counterclockwise movement of the servo arm causes a nose down elevator movement.</p> <p>After selecting the proper servo direction, the installer should engage the autopilot system in normal mode and verify proper elevator response by rotating the pitch reference up and down from the current pitch.</p>

*Available in normal mode

Table 8-8 Autopilot Pitch Servo Configuration Settings

Configuration Setting	Description
Clutch Monitor	<p>The GSA 28 pitch servo has the ability to monitor itself for a stuck clutch situation.</p> <p>If the servo has a large amount of side loading (typically due to a capstan installation), this can occasionally lead to invalid stuck clutch failures. The Clutch Monitor should be enabled for all control arm installations.</p> <p>The Clutch Monitor can be disabled for capstan installations with larger side loads to prevent invalid stuck clutch failures.</p>
Trim Motor Control	<p>The GSA 28 pitch servo has the ability to control an auxiliary pitch trim motor. The Trim Motor Control should be enabled if the GSA 28 pitch servo is connected to an elevator trim motor.</p> <p>The Trim Motor Control should be disabled if the GSA 28 pitch servo is not connected to an auxiliary trim motor.</p>
Trim Motor Direction	<p>The GSA 28 pitch servo has a configurable trim motor direction. Select the Normal or Reversed setting depending on which is required for the proper trim motor movement when using the aircraft trim motor switches on the ground with the autopilot disengaged (servos powered).</p>
Fastest Trim Motor Speed	<p>The GSA 28 pitch servo will control the elevator trim on the aircraft. The Fastest Trim Motor Speed is the speed at which the pitch servo will run the auxiliary trim motor when at or below the corresponding airspeed.</p> <p>Expressed as a percentage of the maximum auxiliary trim motor speed. The Fastest Trim Motor Speed can be adjusted from 5% to 100% in 5% steps.</p>
Slowest Trim Motor Speed	<p>The GSA 28 pitch servo will control the elevator trim on the aircraft. The Slowest Trim Motor Speed is the speed at which the pitch servo will run the auxiliary trim motor when at or above the corresponding airspeed.</p> <p>Expressed as a percentage of the maximum auxiliary trim motor speed. The Slowest Trim Motor Speed can be adjusted from 5% to 100% in 5% steps</p>
Slowest Auto Trim Motor Speed (expert configuration)	<p>The GSA 28 pitch servo has the ability to drive the auxiliary trim motor at various speeds.</p> <p>The Slowest Auto Trim Motor Speed should be set so the auxiliary trim motor will move as slowly as possible. The slowest possible movement will ensure there is no noticeable aircraft response when the auxiliary trim motor is run during autotrim.</p> <p>The Slowest Auto Trim Motor Speed can be adjusted from 5% to 100% in 5% steps.</p>
Maximum Trim Run Time	<p>The GSA 28 servos can limit the maximum continuous run time of the trim motor. This can be used to help prevent the potential for a trim runaway situation.</p> <p>The Maximum Trim Run Time Limit is the maximum amount of time the trim servo will be run continuously when a manual electric trim input is detected. If the maximum time is exceeded, the pilot will need to release the Manual Electric Trim (MET) control and then reassert it to continue running trim.</p>

*Available in normal mode

Table 8-8 Autopilot Pitch Servo Configuration Settings

Configuration Setting	Description
Fine Adjust Amount (expert configuration)	<p>The GSA 28 pitch servo is capable of making very small adjustments to fine tune the elevator position. The Fine Adjust Amount is the amount in which these adjustments are made. Use the Fine Adjust Amount and Fine Adjust Time to correct very small oscillations in the aircraft.</p> <p>Fine Adjust Amount is an expert configuration setting, and should generally be not be changed by the installer. The default value is 0.</p>
Fine Adjust Time (expert configuration)	<p>The GSA 28 pitch servo is capable of making very small adjustments to fine tune the elevator position. The Fine Adjust Time is the rate at which these adjustments are made. Use the Fine Adjust Amount and Fine Adjust Time to correct very small oscillations in the aircraft.</p> <p>Fine Adjust Time is an expert configuration setting, and should generally be not be changed by the installer. The default value is 0.20.</p>
Minimum Airspeed Limit*	<p>The GSA 28 pitch servo has a configurable minimum airspeed limit. This determines the lowest airspeed at which the pitch servo will allow the aircraft to fly. If the airspeed drops below this limit, the pitch servo will lower the nose of the aircraft to keep the airspeed at or above the Minimum Airspeed Limit.</p> <p>The Minimum Airspeed Limit should be set above the aircraft stall speed with some margin.</p>
Maximum Airspeed Limit*	<p>The GSA 28 pitch servo has a configurable maximum airspeed limit. This determines the fastest airspeed at which the pitch servo will allow the aircraft to fly. If the airspeed rises above this limit, the pitch servo will raise the nose of the aircraft to keep the airspeed at or below the Maximum Airspeed Limit.</p> <p>The Maximum Airspeed Limit should be set below the aircraft maximum speed with some margin.</p>
Vertical Speed Gain*	<p>The GSA 28 pitch servo is capable of holding the aircraft at a desired vertical speed.</p> <p>The Vertical Speed Gain should be increased if the aircraft struggles to hold the desired vertical speed target when the flight director is in VS, ALT, or LVL modes.</p> <p>The Vertical Speed Gain should be decreased if the aircraft is overly aggressive when trying to hold the desired vertical speed.</p>
Vertical Acceleration Gain*	<p>The GSA 28 pitch servo is capable of holding the aircraft at a desired vertical speed.</p> <p>The Vertical Acceleration Gain should be increased if the aircraft is overshooting the desired vertical speed target when closing on the bug when the flight director is in VS mode.</p> <p>The Vertical Acceleration Gain should be decreased if the aircraft appears to back off from the desired vertical speed target when closing on the bug.</p>

*Available in normal mode

Table 8-8 Autopilot Pitch Servo Configuration Settings

Configuration Setting	Description
Airspeed Gain*	<p>The GSA 28 pitch servo is capable of holding the aircraft at a desired airspeed.</p> <p>The Airspeed Gain should be increased if the aircraft is lazy and struggles to hold the desired airspeed target when the flight director is in IAS mode.</p> <p>The Airspeed Gain should be decreased if the aircraft is overly aggressive when trying to hold the desired airspeed target.</p>
Airspeed Acceleration Gain (expert configuration)	<p>The GSA 28 pitch servo is capable of holding the aircraft at a desired airspeed.</p> <p>The Airspeed Acceleration Gain should be increased if the aircraft is overshooting the desired airspeed target when closing on the bug when the flight director is in IAS mode.</p> <p>The Airspeed Acceleration Gain should be decreased if the aircraft appears to back off from the desired airspeed target when closing on the bug.</p>
Airspeed Tracking Gain (expert configuration)	<p>The GSA 28 pitch servo is capable of holding the aircraft at a desired airspeed.</p> <p>The Airspeed Tracking Gain should be increased if the aircraft is overly sluggish while tracking airspeed when the airspeed error is less than 5 knots.</p> <p>The Airspeed Tracking Gain should be decreased if the aircraft is overly aggressive while tracking airspeed when the airspeed error is less than 5 knots.</p>

*Available in normal mode

Yaw Damper Configuration Page

The installer needs to make the following yaw damper configuration selections when setting up the GSA 28 based autopilot system. All selections are available in configuration mode using the Yaw Damper page. Selections available in the normal mode Setup menu are noted with an asterisk in Table 8-9.



Figure 8-32 Yaw Damper Configuration Page

Table 8-9 Yaw Damper Configuration Settings

Configuration Setting	Description
Maximum Torque*	<p>The GSA 28 yaw damper has a configurable maximum torque setting. This determines how much torque the servo will output before the electronic slip clutch begins to slip.</p> <p>The Maximum Torque setting should be set high enough to not slip during in-flight air loading, but low enough for the pilot to override the autopilot if required. The Maximum Torque setting can be adjusted from 15% to 100% in 5% steps.</p>
Servo Gain*	<p>The GSA 28 yaw damper has a configurable servo gain setting. This determines how aggressively the yaw servo will move the rudder surface.</p> <p>The Servo Gain should be set high enough to dampen the yaw rates, but low enough to avoid being overly aggressive in the rudder movements. The servo gain setting can be adjusted from 0.00 to 10.00 in steps of 0.05.</p>
Servo Direction	<p>The GSA 28 yaw damper has a configurable servo direction.</p> <p>The Servo Direction should be set to Normal if a clockwise movement of the servo arm causes a nose left rudder movement.</p> <p>The Servo Direction should be set to Reverse if a counterclockwise movement of the servo arm causes a nose left rudder movement.</p> <p>After selecting the proper servo direction, the installer should engage the yaw damper in normal mode and verify proper rudder response by the tail of the aircraft back and forth.</p>

*Available in normal mode

Table 8-9 Yaw Damper Configuration Settings

Configuration Setting	Description
Clutch Monitor	<p>The GSA 28 yaw damper has the ability to monitor itself for a stuck clutch situation.</p> <p>If the servo has a large amount of side loading (typically due to a capstan installation), this can occasionally lead to invalid stuck clutch failures. The Clutch Monitor should be enabled for all control arm installations.</p> <p>The Clutch Monitor can be disabled for capstan installations with larger side loads to prevent invalid stuck clutch failures.</p>
Trim Motor Control	<p>The GSA 28 yaw damper has the ability to control an auxiliary rudder trim motor. The Trim Motor Control should be enabled if the GSA 28 yaw damper is connected to an elevator trim motor.</p> <p>The Trim Motor Control should be disabled if the GSA 28 yaw damper is not connected to an auxiliary trim motor.</p>
Trim Motor Direction	<p>The GSA 28 yaw servo has a configurable trim motor direction. Select the Normal or Reversed setting depending on which is required for the proper trim motor movement when using the aircraft trim motor switches on the ground with the autopilot disengaged (servos powered).</p>
Fastest Trim Motor Speed	<p>The GSA 28 yaw servo will control the rudder trim on the aircraft. The Fastest Trim Motor Speed is the speed at which the yaw damper will run the auxiliary trim motor when at or below the corresponding airspeed. Expressed as a percentage of the maximum auxiliary trim motor speed. The Fastest Trim Motor Speed can be adjusted from 5% to 100% in 5% steps.</p>
Slowest Trim Motor Speed	<p>The GSA 28 yaw servo will control the rudder trim on the aircraft. The Slowest Trim Motor Speed is the speed at which the yaw damper will run the auxiliary trim motor when at or above the corresponding airspeed. Expressed as a percentage of the maximum auxiliary trim motor speed. The Slowest Trim Motor Speed can be adjusted from 5% to 100% in 5% steps.</p>
Slowest Auto Trim Motor Speed (expert configuration)	<p>The GSA 28 yaw damper has the ability to drive the auxiliary rudder trim motor at various speeds. The Slowest Auto Trim Motor Speed should be set so the auxiliary trim motor will move as slowly as possible. The slowest possible movement will ensure there is no noticeable aircraft response when the auxiliary trim motor is run during autotrim.</p> <p>The Slowest Auto Trim Motor Speed can be adjusted from 5% to 100% in 5% steps.</p>
Maximum Trim Run Time	<p>The GSA 28 servos can limit the maximum continuous run time of the trim motor. This can be used to help prevent the potential for a trim runaway situation. The Maximum Trim Run Time Limit is the maximum amount of time the trim servo will be run continuously when a manual electric trim input is detected. If the maximum time is exceeded, the pilot will need to release the Manual Electric Trim (MET) control and then reassert it to continue running trim.</p>

*Available in normal mode

Table 8-9 Yaw Damper Configuration Settings

Configuration Setting	Description
Ball Centering Gain (expert configuration)	<p>The GSA 28 yaw damper is capable of zeroing the aircraft's lateral acceleration or centering the ball as well as dampening aircraft yaw rates.</p> <p>Ball Centering Gain is an expert configuration setting and should only be changed by the installer if the yaw damper is not properly zeroing the aircraft's lateral acceleration.</p> <p>Increasing the Ball Centering Gain will cause the yaw damper to more aggressively respond to non-zero lateral acceleration. Decreasing the Ball Centering Gain will cause the yaw damper to respond less aggressively to non-zero lateral acceleration.</p>
Yaw Rate Filter Constant (expert configuration)	<p>The GSA 28 yaw damper is capable of dampening yaw body rates to keep the aircraft from shaking its tail. The Yaw Rate Filter Constant is used to filter the aircraft yaw body rate.</p> <p>Yaw Rate Filter Constant is an expert configuration setting, and should generally be not be changed by the installer. The default value is 0.08.</p>
Yaw Acceleration Filter Constant (expert configuration)	<p>The GSA 28 yaw damper is capable of zeroing the lateral acceleration of the aircraft. The Yaw Acceleration Filter Constant is used to filter the aircraft lateral acceleration.</p> <p>Yaw Acceleration Filter Constant is an expert configuration setting, and should generally be not be changed by the installer. The default value is 0.16.</p>

*Available in normal mode

8.4.8 Flight Director Configuration Page

This page allows for configuration of certain options for the flight director. It will only appear in installations that include an autopilot.

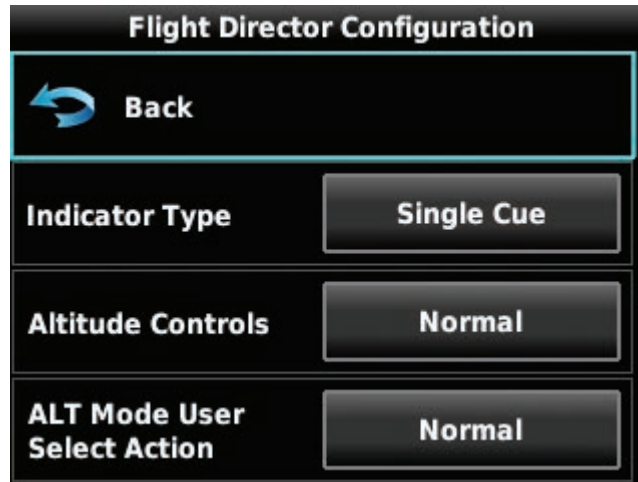

Figure 8-33 Flight Director Configuration Page

Table 8-10 Flight Director Configuration Settings

Configuration Setting	Description
Indicator Type	Controls whether the flight director command indicator on the PFD uses a single-cue or dual-cue presentation.
Altitude Controls	Select Normal (default) or Simplified. Selecting Simplified results in a simpler set of behaviors for altitude hold mode. When Altitude Controls is set to Normal, ALT Mode User Select Action and ALT Mode User Up/Down Action will appear. When Altitude Controls is set to Simplified, the ALT Mode User Select Action and ALT Mode User Up/Down Action settings do not appear. In their places, selections for the default climb and descent vertical speeds are displayed.
ALT Mode User Select Action	Select Normal or Sync Selected Altitude. This setting controls the actions that occur when the user selects altitude hold mode by pressing the ALT key on the GMC Mode Controller. When set to Sync Selected Altitude, the selected altitude (altitude bug) will be automatically set to the current aircraft altitude when the user selects altitude hold mode manually by pressing the ALT key on the GMC Mode Controller.
ALT Mode User Up/Down Action	Select Normal or Select VS Mode. This setting controls the actions that occur when the flight director is in altitude hold mode and the user moves the pitch wheel on the GMC Mode Controller. When set to Select VS Mode, moving the pitch wheel on the GMC Mode Controller results in a change to VS mode for a climb or descent to a new altitude.
Maximum Bank Angle	Used to limit the maximum roll attitude commanded by the flight director for aircraft that have unusual attitude limitations. This setting should not be adjusted from the default of 30° except for very high performance aircraft that have bank angle limitations at high speeds.

8.4.9 Electronic Stability Protection Configuration Page

This page allows for configuration of certain options for the ESP™ (Electronic Stability Protection) function. It will only appear in installations that include an autopilot with Garmin servos. ESP is an optionally enabled feature that is intended to assist the pilot in maintaining the aircraft in a stable flight condition. This feature will only function when the aircraft is above 200 feet AGL and the autopilot is not engaged.

ESP engages when the aircraft exceeds one or more conditions (pitch, roll, airspeed) beyond the normal flight parameters. Enhanced stability for each condition provides a force to the appropriate control surface to return the aircraft to the normal flight envelope. This is perceived by the pilot as resistance to control movement in the undesired direction when the aircraft approaches a steep attitude or high airspeed. As the aircraft deviates further from the normal attitude and/or airspeed, the force increases (up to an established maximum) to encourage control movement in the direction necessary to return to the normal attitude and/or airspeed range.

See the G5 Pilot's Guide (190-02072-00) for details of ESP operation.

Table 8-11 ESP Configuration Settings

Configuration Setting	Description
Roll Attitude Protection	Select Enabled or Disabled (all other fields remain blank when Disabled).
Roll Limit	Enter desired Bank Limit of aircraft (range 45° to 60°, this limit will appear as Guardrails on the PFD).
Pitch Attitude Protection	Select Enabled or Disabled.
Pitch Up Limit	Enter desired Pitch Limit of aircraft. Allowable range of +10° to +25° (default setting +20°)
Pitch Down Limit	Enter desired Pitch Limit of aircraft. Allowable range of -10° to -25° (default setting -15°)
Airspeed Protection	Select Enabled or Disabled. Note the minimum airspeed setting should be set to a value lower than the minimum airspeed that is anticipated during approach while above 200 ft AGL.
Minimum Airspeed Limit	Enter minimum airspeed of aircraft, minimum setting is 50 kt
Maximum Airspeed Limit	Enter maximum airspeed of aircraft, maximum setting is 999 kt
Default ESP Powerup State	Select Enabled or Disabled. Setting determines whether the ESP is functioning upon start. If disabled, ESP can still be enabled in normal operating mode.
Auto Engage LVL Mode	Select Enabled or Disabled. When enabled, the autopilot will engage with the flight director in Level Mode to bring the aircraft into level flight if ESP has been engaged for more than 15 seconds of a 30 second time period.

8.4.10 Backlight Configuration Page

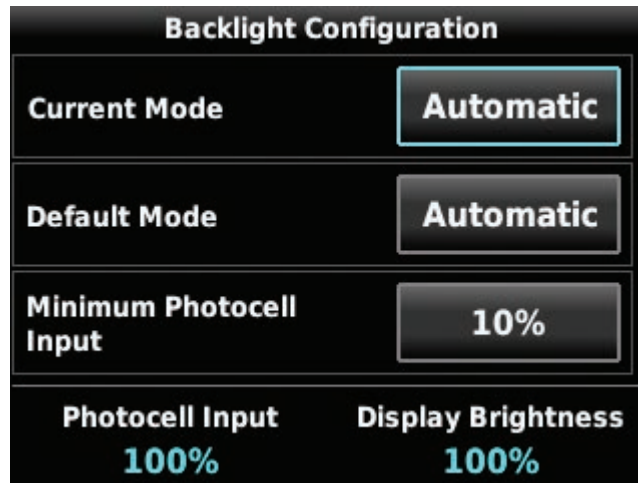

Figure 8-34 Backlight Configuration Page

Table 8-12 Backlight Configuration Settings

Configuration Setting	Description
Current Mode	Used to set the backlight mode to automatic or manual. This setting is also available at any time by pressing the power button. Automatic mode sets the backlight intensity (display brightness) based on the photocell (ambient light sensor) input on the G5. Manual mode allows for setting the backlight intensity by changing the Backlight percentage directly. Manual brightness control is available at any time by pressing the power button.
Default Mode	Used to set the backlight mode that will be active each time the unit is powered on.
Minimum Photocell Input	Sets the photocell reading that will result in the minimum display brightness in automatic mode. The default is 10%.
Minimum Display Brightness	Sets the minimum display brightness setting that will occur in automatic mode. The default value is 20%.
Maximum Photocell Input	Sets the photocell reading that will result in the maximum display brightness in automatic mode. The default is 70%.
Maximum Display Brightness	Sets the maximum display brightness setting that will occur in automatic mode. The default value is 100%.
Filter Time Constant	Adjusts the speed (in seconds) the brightness level responds to changes in the photocell input.
Photocell Input	Displays the current input on the unit's light sensor (0%-100%).
Display/Manual Brightness	Displays the current backlight level (0%-100%). Naming convention depends on the current backlight mode selected.

8.4.11 Display Configuration Page

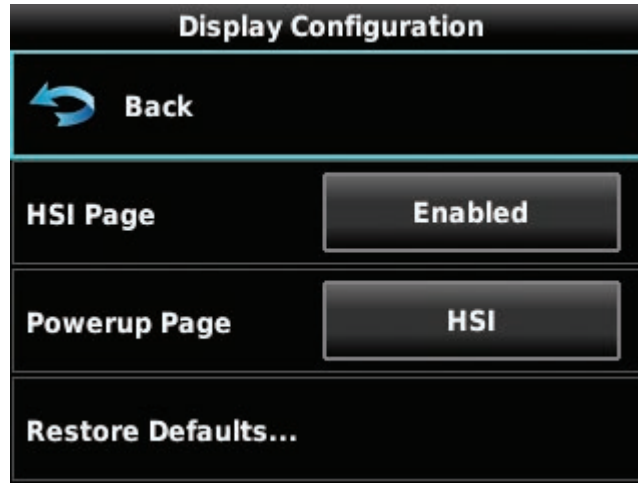

Figure 8-35 Display Configuration Page

Table 8-13 Display Configuration Settings

Configuration Setting	Description
HSI Page	Enables and disables access to the HSI page in normal mode.
Powerup Page	Sets the default page (PFD or HSI) displayed at unit power on. The HSI page cannot be configured as the default powerup page on the #1 G5 in a G3X system.

8.4.12 Battery Configuration Page

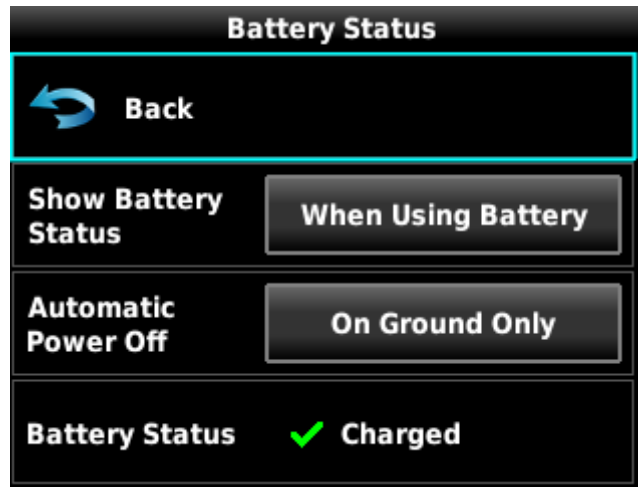

Figure 8-36 Battery Status Page

In addition to the configuration settings listed in Table 8-14, this page also displays the following battery information:

- Battery Status
- Charge Level
- Temperature
- Voltage
- Charge Cycles
- Lifetime Remaining

Table 8-14 Battery Configuration Settings

Configuration Setting	Description
Show Battery Status	Select When Using Battery to only display the status of the G5 backup battery when the unit is operating from the battery (i.e. aircraft power has been removed). Select Always to constantly display the status of the G5 backup battery. The battery status will be displayed regardless of the status of aircraft power or whether a battery is connected to the G5.
Automatic Power Off	Select Always to initiate the external power lost countdown timer anytime the G5 loses power. Select On Ground Only* to initiate the external power lost countdown timer only when the G5 loses power and the airspeed is less than 20 kts.

*Recommended setting

8.4.13 GPS Configuration Page

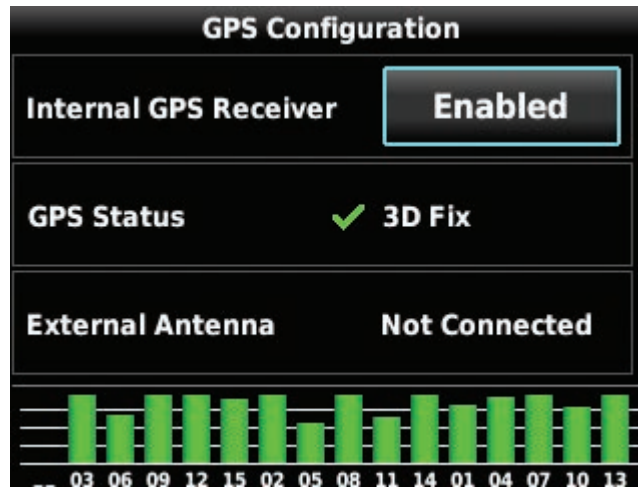

Figure 8-37 GPS Configuration Page

Table 8-15 GPS Configuration Settings

Configuration Setting	Description
Internal GPS Receiver	Enables and disables the internal GPS receiver on the G5. The internal receiver is typically disabled in installations where the mounting location leads to poor GPS reception and an external GPS antenna is not installed. When the internal GPS receiver is disabled, the G5 is still able to receive GPS data from an external navigation source such as other Garmin LRUs (e.g. GDU37X/4XX, GPS 20A, or secondary G5).
GPS Status	Displays the status of the internal GPS receiver on the G5. A green check mark indicates a valid GPS fix has been acquired.
External Antenna	Displays the connection status of the external GPS antenna (if equipped).
GPS Data Fields	Shows and hides the GPS data from the PFD. When hidden, GPS data is still used for attitude validation (when available).

8.4.13.1 GPS Signal Reception

G5 installations generally have better GPS reception when using an external GPS antenna versus the internal GPS antenna. The GPS Configuration page can be used to find the quality of GPS reception using either antenna. Gray signal strength bars and the lack of a green check mark indicate weak GPS signal reception. Green bars and a green check mark indicate good GPS signal reception. Taller bars indicate better reception than shorter bars. More signal strength bars produce a better position fix than fewer bars.

Figure 8-38 shows an example of an installation that receives inadequate GPS signal reception (note that all signal strength bars are gray indicating weak signal). The received signal is not sufficient to improve the attitude measurement, although it is sufficient to find and display the basic track and ground speed information.

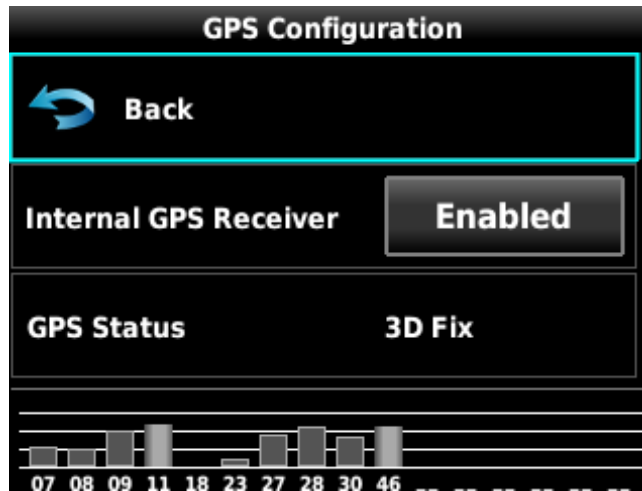

Figure 8-38 GPS Configuration Page Showing Inadequate Signal Reception

Figure 8-39 is an example of an installation with marginally acceptable GPS signal reception. Five or more green signal strength bars must be consistently displayed before the G5 can use GPS data to improve the attitude measurement.

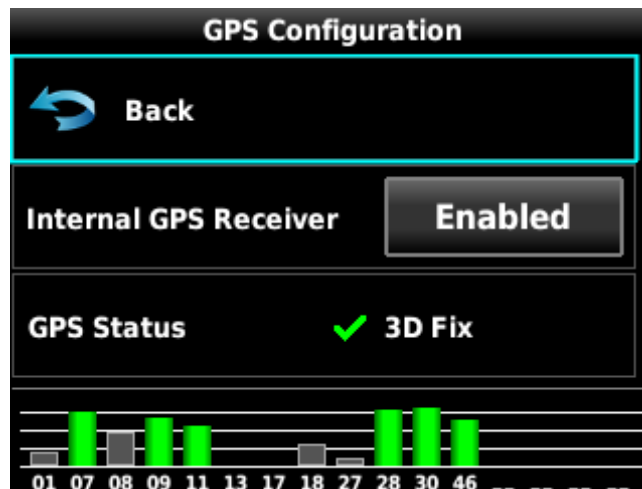

Figure 8-39 GPS Configuration Page Showing Marginally Acceptable Signal Reception

Figure 8-40 is an example of an installation that has good GPS signal reception with many more than the minimum required five green signal strength bars displayed. A 3D Differential position fix is the goal for G5 installations when using the internal GPS receiver. A 3D Differential position fix cannot be calculated in areas/countries that do not use SBAS (Satellite Based Augmentation Systems), in those areas, receiving the most green bars is the most important indication.

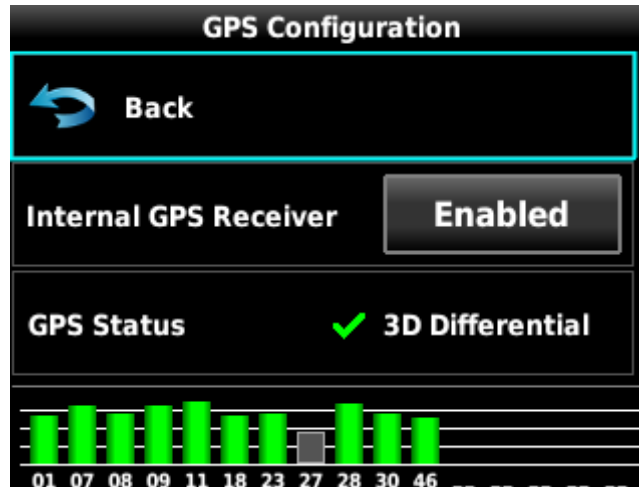

Figure 8-40 GPS Configuration Page Showing Good Signal Reception

8.4.13.2 Testing the GPS Receiver for COM Interference

This test must be conducted outside, as the use of a GPS repeater inside a hangar may result in a failed test.

1. Ensure a valid GPS position fix is obtained by monitoring the GPS status. The following status indications are valid fixes for this test.
 - 3D Fix
 - 3D Differential
2. Select 121.150 MHz on the COM transceiver.
3. Transmit for a period of 30 seconds while monitoring the GPS status.
4. During the transmit period, verify the GPS status does not lose a valid GPS position fix.
5. Repeat steps 2 through 4 for the following frequencies:
 - 121.175 MHz
 - 121.200 MHz
 - 131.250 MHz
 - 131.275 MHz
 - 131.300 MHz
6. Repeat steps 2 through 5 for all other installed COM transceivers (if applicable).
7. If an installed COM supports 8.33 MHz channel spacing, increase the transmit period to 35 seconds and repeat steps 3 through 5 for the following frequencies:
 - 121.185 MHz
 - 121.190 MHz
 - 130.285 MHz
 - 131.290 MHz

- Repeat step 7 for all other installed COM transceivers supporting 8.33 MHz channel spacing (if applicable).

**NOTE**

The signal strength bars at the bottom of the GPS Configuration page are a real-time representation of GPS signal strength, which may be useful for troubleshooting a failed COM interference test.

8.4.13.3 Navigation Configuration Page

This page is only available if a navigation data source is configured through RS-232 or ARINC 429.

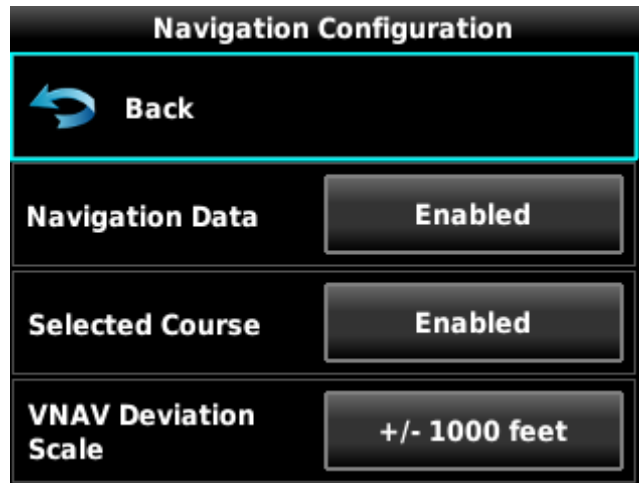

Figure 8-41 Navigation Configuration Page

Table 8-16 Navigation Configuration Settings

Configuration Setting	Description
Navigation Data	<p>For a standalone unit (not part of a G3X system), this setting enables and disables the display of navigation data in normal mode. Navigation data cannot be hidden when autopilot servos are configured.</p> <p>For a backup unit (part of a G3X system), this setting controls how the G5 selects the navigation data source to display when communicating with a G3X display. Select Auto to display navigation data from the #1 ARINC 429 source when the G3X display is showing the same navigation data. If the G3X display's navigation source is changed to internal GPS or a navigation source not supported by the G5, then no navigation data will be displayed on the G5. This prevents the G5 and G3X display from showing different sources of navigation data simultaneously.</p> <p>Select Always Display to always show the navigation data the G5 is receiving over RS-232 and/or the #1 ARINC 429 source, even if that data is different than what is shown on the G3X display.</p> <p>Regardless of the Navigation Data setting, when no G3X displays are present, the G5 will always display the navigation data it is receiving over RS-232 and/or the #1 ARINC 429 source, or when dual navigation sources are installed, the G5 will display the navigation data from the selected source.</p>
Selected Course	<p>For a standalone unit (not part of a G3X system) this setting determines whether the G5 can perform course selection for external navigation sources. Select "Disabled" if a mechanical CDI or HSI is connected to the navigator, otherwise select "Enabled".</p>
VNAV Deviation Scale	<p>For a standalone unit (not part of a G3X system) this setting determines the full-scale value for VNAV deviation data received from an external navigator (+/- 500 feet or +/- 1000 feet). This should be configured to match the navigator's VNAV deviation scale configuration.</p>

8.4.13.4 Units Configuration Page

This page allows for configuration of the displayed units. The units for each measurement can be selected using the knob on the G5.

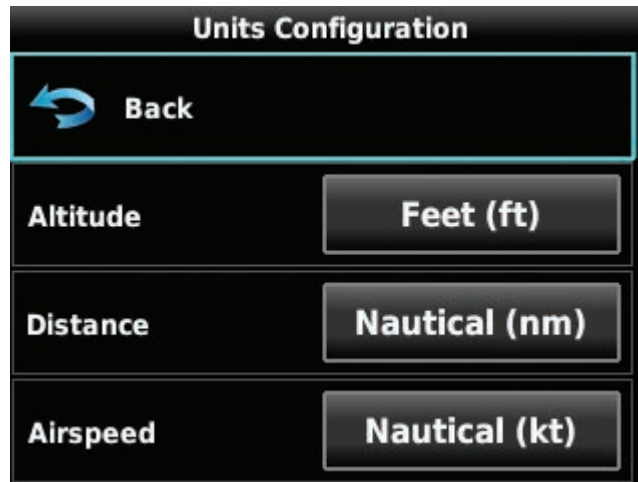

Figure 8-42 Units Configuration Page

The Units Configuration page also allows for the selection of Normal or Alternate Data Field Units Display. Normal corresponds to unit labeling that is consistent with the G3X system - color-matched to the value and displayed to the right of the value.



Figure 8-43 Normal Data Field Units

Selecting Alternate will slightly change the display of the data field units. On the PFD page, the unit symbols will be removed from the groundspeed, selected altitude, and barometric setting fields.



Figure 8-44 Alternate Data Field Units on PFD Page

If the units for airspeed and groundspeed are not the same, the title for the groundspeed field will be moved above the value and updated to include the unit (color-matched to the title).



Figure 8-45 Non-Matching Airspeed and Groundspeed Units

On the HSI page, all data field titles will be moved above the value and updated to include the unit (color-matched to the title).



Figure 8-46 Alternate Data Field Units on HSI Page

8.4.13.5 RS-232 Configuration Page

This page allows for configuration of the serial communication port on the G5. Both the input and output serial port formats can be configured independently. Some input/output formats will also allow for a configurable baud rate.

A green checkmark will appear next to the input format selection when the RS-232 port is receiving valid data. A green checkmark will not appear if data has not yet been received by the unit. A red "X" is displayed if no data has been received after an initial time-out period, or if data has been received and is then interrupted.

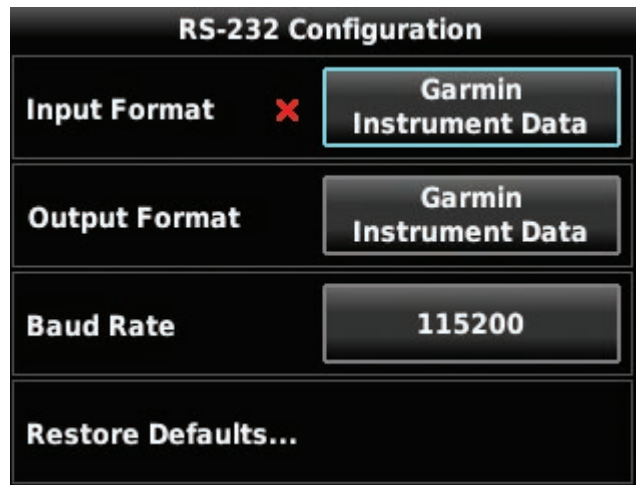

Figure 8-47 RS-232 Configuration Page

Table 8-17 RS-232 Input Configuration Settings

Configuration Setting	Description
Aviation	The proprietary format used for input of navigation data to the G5 at a fixed baud rate of 9600 from an FAA certified Garmin panel mount unit. If the external GPS navigator supports both the Aviation and MapMX formats, the MapMX format is recommended.
Garmin Instrument Data	Used for connecting to compatible Garmin LRUs (e.g. GMC 305/307).
Garmin VHF Nav Radio	Receives lateral and vertical NAV deviation signals as an input format. Transmits GPS data and selected course to a GNC® 255 or SL 30 NAV radio.
MapMX	The preferred input format when interfacing with an external navigator. This format is only available from Garmin units equipped with a WAAS GPS receiver. MapMX Format 1 and MapMX Format 2 are also acceptable formats for the navigator serial port configuration when using MapMX format on the G5. In a dual GNS™/GTN™ installation, connect the MapMX output from unit #1 to the G5.
NMEA	Supports the input and output of standard NMEA 0183 version 3.01 data at a configurable baud rate of either 4800 or 9600. The G5 outputs GPS data using NMEA sentences. This input format is used when interfacing a portable GPS navigation unit like a Garmin aera® 660.

Table 8-18 RS-232 Output Configuration Settings

Configuration Setting	Description
Altitude Encoder	Outputs altitude encoder data to a compatible transponder. Both Icarus and Shadin-format messages are output when using this setting.
Garmin Instrument Data	Used for connecting to compatible Garmin LRUs (e.g. GMC 305/307).
Garmin VHF Nav Radio	Receives lateral and vertical NAV deviation signals as an input format. Transmits GPS data and selected course to a GNC 255 or SL 30 NAV radio.
NMEA	Supports the input and output of standard NMEA 0183 version 3.01 data at a configurable baud rate of either 4800 or 9600. The G5 outputs GPS data using the NMEA sentences: GPGGA, GPGLL, GPRMC, PGRMZ, and GPGSA
Text	Outputs attitude, air data, and GPS position/velocity text data as described in Section 11.4

8.4.13.6 ARINC 429 Configuration Page

This page allows for configuration of the 2 ARINC 429 output and 4 ARINC 429 input ports on the G5.

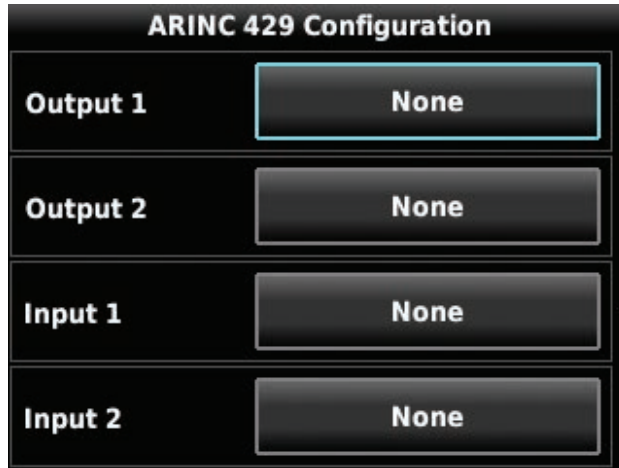

Figure 8-48 ARINC 429 Configuration Page

Table 8-19 ARINC 429 Outputs

Configuration Setting	Description
EFIS/Airdata 1 (SDI 1, SDI 2, common)	Outputs EFIS and air data labels. The transmitted labels are as follows:
	100P Selected GPS Course
	101 Selected Heading
	102 Selected Altitude
	110 Selected VLOC Course
	203 Pressure Altitude
	204 Baro Corrected Altitude
	205 Mach Number
	206 Indicated Airspeed
	210 True Airspeed
	211 Total Air Temperature
	212 Vertical Speed
	213 Static Air Temperature
	235 Baro Setting (BCD)
	320 Magnetic Heading
	371G Manufacturer ID
377 Equipment ID	

Table 8-19 ARINC 429 Outputs

Configuration Setting	Description
EFIS/Airdata 2 (SDI 1, SDI 2, common)	Outputs EFIS and air data labels. The transmitted labels are as follows: 100P Selected Course (GPS or VLOC) 101 Selected Heading 102 Selected Altitude 110 Selected VLOC Course 203 Pressure Altitude 204 Baro Corrected Altitude 205 Mach Number 206 Indicated Airspeed 210 True Airspeed 211 Total Air Temperature 212 Vertical Speed 213 Static Air Temperature 235 Baro Setting (BCD) 320 Magnetic Heading 371G Manufacturer ID 377 Equipment ID
EFIS Course (SDI 1, SDI 2, Common)	100P Selected GPS Course 371G Manufacturer ID 377 Equipment ID

Table 8-20 ARINC 429 Inputs

Configuration Setting	Description
Garmin GPS (SDI 1, SDI 2, Common)	Receives GPS labels from a GNS 4XX/5XX or GTN 6XX/7XX series unit.
Garmin VOR/ILS (SDI 1, SDI 2, Common)	Receives VOR/ILS labels from a GNS 4XX/5XX, GTN 6XX/7XX, or GNC 255 unit.

9 TROUBLESHOOTING

In this manual, the term ‘Red-X’ refers to a red “X” that appears on different areas of the display to indicate the failure of that particular function.

For additional assistance, contact your local avionics dealer. If further help is needed, contact Garmin Aviation Product Support at US Toll Free Number 1-888-606-5482, or US 1-913-397-8200.



NOTE

The information in this section is for troubleshooting use only and does not supersede any approved maintenance or other installation instructions.

9.1 General Troubleshooting

1. Review the airframe logbook to verify if any G5 or other avionics or electrical maintenance had been performed recently that may have contributed to the failure.
2. Check for loose wire terminals on the circuit breaker connections on the power wire(s) causing intermittent power connections. Also, check for intermittent circuit breakers.
3. Have ground power put on the aircraft.
4. Turn on the G5 and record the system software version displayed on the start up page.
5. After the system is initialized, note any Red-X’s on the display or anywhere in the configuration mode menus.

If the failure cannot be verified, proceed to the following physical inspection.

1. Power cycle the G5 or any affected LRU by removing aircraft power, waiting 30 seconds, then reapplying power.
2. Check that all connectors are fully seated, and that the jack screw connectors are fully tightened on both sides of all connectors.
3. Check for a loose wire harness that is able to move around during flight. This condition may cause the wire to pull on or vibrate the connector, making intermittent connections.
4. Ensure that the G5 or any affected LRU is mounted securely. Use the appropriate tool to check the tightness of all mounting hardware.
5. Look for any heavy objects that may not be fastened tight to the aircraft structure that could be inducing vibration in the G5’s attitude sensors.
6. Look for evidence of water or fluid contamination in the area around the G5 or any affected LRU.
7. Unplug the connector on the G5 or any affected LRU and check for bent pins.
8. Inspect the wire harness clamp on the rear of all connectors to verify that it is not too tight and smashing/shorting the wires. If the wire clamp is installed upside down, it has sharp edges that can cut into the wires. Verify the presence of protective wire wrap between the wires and the clamp.

If the condition is not resolved by following the preceding instructions, contact Garmin Product Support for additional assistance. A Garmin Field Service Engineer may ask the technician to email any fault or data logs back to Garmin to help determine if the condition is caused by a G5, a different LRU, or a source elsewhere in the aircraft installation.

9.2 SD Card Slot

A stuck or sticking microSD™ card issue can sometimes be caused by the card thickness variability (especially if there is more than one label on the card). This is usually caused by the card sticking in the overlay opening, not by the card sticking to the socket inside the unit. Try another card (without a label, if possible) to confirm the problem before returning. If the second card sticks, the microSD™ socket board inside the unit may be misaligned with the overlay and the G5 will require repair. If the thickness of the card was the cause, see if more than one label was on the card. If the labels weren't the cause, determine what brand of microSD™ card was being used (Garmin recommends using SanDisk® brand cards).

9.3 Unit Communication Error

Communication errors can occur in systems with two G5s due to software versions and unit ID strapping. Multiple G5s connected together should have the same software version installed. Differing versions will be annunciated with a message in normal mode (e.g. "Software version mismatch") and a Red-X in configuration mode. More than one G5 strapped as the same unit (i.e. both unit 1 or both unit 2) will be annunciated with a message (e.g. "Communication error" or "Network address conflict") in normal mode and a Red-X in configuration mode.

9.4 Air Data Troubleshooting

Under normal operating conditions, the G5 provides the following air data information:

- Indicated Airspeed (IAS)
- Barometric Altitude
- Vertical Speed



NOTE

IAS information can only be displayed at speeds greater than 20 knots.

If the airspeed and/or altitude is failed and shows a Red-X condition:

1. Inspect the pitot/static plumbing integrity.
2. Inspect the pitot/static ports and all associated equipment.
3. If the problem persists, replace the G5 with a known good unit.

9.5 Attitude Failure Troubleshooting

To assist with troubleshooting an attitude or track failure, gather answers to the following questions, being as specific as possible. This information may be helpful to the installer/pilot, the avionics dealer, or to Garmin Aviation Product Support in troubleshooting the failure.

1. What was the nature of the failure? Was it a Red-X of only heading, only GPS track, only pitch/roll, or a combination?
2. If there was a Red-X of pitch or roll information, did the unit display an alignment message (which is indicative of a reset), or a failure message (which is indicative of an invalidated output)?
3. What was the aircraft doing in the two minutes that preceded the failure (taxing on the ground, flying straight-and-level flight, turning, climbing, etc.)? If the problem occurred on the ground, was it within 100 feet of a hanger using GPS repeaters?
4. How long did the failure last? Was it brief or sustained? Was it repetitive in nature? If it was repetitive, about how many times did it happen? Did it happen on more than one day?
5. Was the problem correlated with a specific maneuver or a specific geographic area?

6. Can the problem be repeated reliably?
7. Did the onset of the problem occur shortly after a software upload to the G5?
8. Was there a loss of the GPS position lock?

9.6 Heading Failure Troubleshooting (with GMU 11)

If a Red-X (steady or intermittent) is displayed in the heading field on the G5, check the following while the aircraft is on the ground:

1. When taxiing, heading performance is susceptible to the presence of magnetic anomalies (metal buildings, underground steel culverts, steel grates in the ramp, rebar, etc.). Localized sources of interference on the ground may consistently cause a Red-X to be displayed on the heading in the same location while taxiing; this is not caused by a failure of the GMU 11 or its calibration.
2. If any new equipment has been installed on the aircraft, conduct the magnetometer interference test procedure (see [Section 8.4.6.5](#)) to see if the new equipment is causing magnetic interference with the GMU 11.
3. With the G5 in configuration mode, select the Device Information page and verify there is a green checkmark next to MAG. If there is a Red-X next to MAG, inspect and verify the CAN bus wiring between the G5 and GMU 11. See the CAN bus troubleshooting steps in [Section 2.2.8](#).
4. If the problem persists, replace the GMU 11 with a known good unit.

9.7 G5 Data Logging

Data logging on the G5 may be used to help troubleshoot issues. Operational data can be gathered from the G5 during flight or on-ground and is stored in *.csv log files on the microSD™ card.

To enable logging on the G5:

1. Power on the unit in configuration mode.
2. Navigate to the Data Log Configuration page (via the Device Information and Diagnostics pages).
3. Select Enabled for the Data Card Log setting.

9.8 Sending Troubleshooting Data to Garmin

To assist with troubleshooting an issue, it may be helpful to send pictures and/or the log files stored on the microSD™ card to Garmin. This data can be especially useful to troubleshoot autopilot, attitude, and air data related issues. This data can be sent to g3xpert@garmin.com for troubleshooting assistance.

10 MAINTENANCE

Periodic maintenance for the G5 is limited to the air data system as listed in Section 10.1. All other maintenance is "on condition" only. Instructions for Continued Airworthiness (ICA) are not required per 14 CFR Part 21 for these products as they have received no FAA approval or endorsement. Garmin recommends that the G5 be inspected for proper operation, secure attachment, integrity of connectors and wiring, cleanliness, leakage of hoses and tubes, and any evidence of damage as part of the required annual or periodic aircraft inspection. For more general inspection guidance, please refer to the applicable sections of CFR Part 43 Appendix D and Chapter 12 of AC 43.13-1B.

10.1 G5 Air Data Periodic Maintenance

Per Part 43 Appendix E, paragraph (b)(2), Garmin recommends a test procedure equivalent to Part 43 Appendix E, paragraph (b)(1), with two exceptions. The tests of sub-paragraph (iv) (Friction) and (vi) (Barometric Scale Error) are not applicable because the digital outputs of the G5 are not susceptible to these types of errors. This procedure is recommended when the static system is opened up (i.e. whenever the G5 is removed or replaced). Garmin also recommends that a leak test be performed following any maintenance action in which the pitot system is opened up.



NOTE

If the G5 is moved or replaced, the Post Installation Calibration Procedures (Section 8.4.6) must be repeated.

10.2 G5 Battery Periodic Maintenance

For maximum battery longevity, store within a temperature range of -4°F to 68°F (from -20°C to 20°C). The G5 battery should be kept partially charged when unused for longer periods of time and should not be stored when completely discharged. Charge the battery to 30% within 1 year of receipt and recharge to 30% every 2 years thereafter if the G5 is not in use.

10.3 Return to Service Information

These return to service procedures are intended to verify the serviceability of the appliance only. These tests alone do not verify or otherwise validate the airworthiness of the installation.



NOTE

A pitot/static check as outlined in 14 CFR 91.411 and Part 43 Appendix E must be completed if the pitot/static lines are broken.

10.3.1 Original G5 is Reinstalled

No software or calibration is required if the original G5 is reinstalled in its original mounting location.

10.3.2 New G5 is Installed

Any time a new G5 is installed, or an existing G5 is moved to a different mounting location, the pitch/roll offset calibration procedure ([Section 8.4.6.1](#)) must be performed. The correct G5 software version will automatically be loaded into the G5 from a connected GDU (if applicable). If a GDU is not connected, the unit software will need to be loaded via the front-facing microSD™ card slot. All unit configuration options will need to be selected as the G5 does not support a configuration module.

10.3.3 G5 installations With a GMU 11

For G5 installations that include a GMU 11, verify the heading display is accurate as indicated by the white numbers displaying the magnetic heading. Any time a GMU 11 is moved or reinstalled, a new magnetometer calibration is required ([Section 8.4.6.6](#)).

11 PERFORMANCE SPECIFICATIONS/LICENSING/COMPLIANCE

11.1 GPS Specifications

Table 11-1 G5 GPS Specifications

Characteristics	Specifications
Acquisition Time	a) Warm Start (position known to 10 nm, time known to 10 minutes, with valid almanac and ephemeris): Less than 5 seconds b) Cold Start (position known to 300 nm, time known to 10 minutes, with valid almanac): Less than 45 seconds c) Always Locate™ (with almanac, without initial position or time): Less than 60 seconds
Update Rate	5 Hz (continuous)
Positional Accuracy	< 10 meters

11.2 G5 Environmental Specifications

The G5 has an operating temperature range of -20°C to +60°C. The G5 will prevent operation from the battery when the battery is outside of this temperature range.

11.3 G5 Performance Specifications

Table 11-2 G5 Performance Specifications

Characteristic	Specifications
Pressure Altitude Range	-1,400 feet to 30,000 feet
Vertical Speed Range	±20,000 fpm
Airspeed Range	300 knots (indicated)
Mach Range	< 1.00 mach
Pitch/Roll Range	±360°
Pitch/Roll Accuracy	±1° (straight and level flight) ±2.5° (normal dynamic maneuvering)*
Rotation Rate Range	±499°/second (automatic recovery when exceeded)
Heading Accuracy (with Optional GMU 11)	±3° (straight and level flight) ±6° (normal dynamic maneuvering)*
Backup Battery (Optional)	Rechargeable Lithium-ion
Battery Life	Up to 4 hours

*Normal dynamic maneuvering is defined as bank angles less than 35° and pitch angles less than 15°.

Due to variations in the Earth's magnetic fields, the operational accuracy of the G5's heading (with optional GMU 11) is unknown in the following regions:

- North of 72° N for all longitudes
- South of 70° S for all longitudes
- North of 65° N between 75° W and 120° W (northern Canada)
- North of 70° N between 70° W and 128° W (northern Canada)
- North of 70° N between 85° E and 114° E (northern Russia)
- South of 55° S between 120° E and 165° E (south of Australia and New Zealand)

11.4 RS-232 Text Output Format

11.4.1 Electrical Interface

The output signals are compatible with RS-232C. Data is generated at the configured baud rate with a word length of 8 bits, one stop bit, and no parity.

11.4.1.1 General Message Output Format

The general text output message format is as follows:

- Escape character ('=' symbol [0x3D hex])
- ID character
- Version character
- Data characters (length determined by message ID)
- Checksum (2-character [1-byte] ASCII hex value that is the sum of all previous bytes including the escape character)
- Carriage return (0x0D hex)
- Line feed (0x0A hex)

An exception to the above is the GPS Data message, which is backwards compatible with the Garmin Simple Text Output format described at: http://www8.garmin.com/support/text_out.html. The GPS Data message has the following format:

- Escape character ('@' symbol [0x40 hex])
- Data characters
- Carriage return (0x0D hex)
- Line feed (0x0A hex)

All text output messages use only printable ASCII characters. For all messages, a value that is out of range, missing, not configured, uncalibrated, or otherwise invalid is indicated by replacing the corresponding bytes within the message with the underscore character ('_' symbol [0x5F hex]).

11.4.2 Attitude/Air Data Message Format

The Attitude/Air Data message is transmitted approximately 10 times per second.

Table 11-3 Attitude/Air Data Message Format

Field Name	Offset	Width	Units	Notes	Min	Max
Escape Character	0	1		'='		
Sentence ID	1	1		'1'		
Sentence Version	2	1		'1'		
UTC hour	3	2	hours		00	23
UTC minute	5	2	minutes		00	59
UTC second	7	2	seconds		00	59
UTC second fraction	9	2	10 ms		00	99
Pitch	11	4	0.1 degrees	positive = up	-900	+900
Roll	15	5	0.1 degrees	positive = right	-1800	+1800
Heading	20	3	degrees	magnetic (G3X backup install only)	000	359
Airspeed	23	4	0.1 knots		0000	9999
Pressure altitude	27	6	feet		-01000	+60000
Rate of turn	33	4	0.1 deg/sec	positive = right	-999	+999
Lateral acceleration	37	3	0.01 G	positive = leftward	-99	+99
Vertical acceleration	40	3	0.1 G	positive = upward	-99	+99
Unused	43	2				
Vertical speed	45	4	10 fpm	positive = up	-999	+999
Unused	49	3				
Altimeter setting	52	3	0.01 inHg	offset from 27.50°	000	400
Checksum	55	2	ASCII hex	sum of prev bytes		
CR/LF	57	2		0x0D/0x0A		
Total Length	59					

11.4.3 GPS Data Message Format

The GPS Data message is transmitted once per second.

Table 11-4 GPS Data Message Format

Field Name	Offset	Width	Units	Notes	Min	Max
Escape character	0	1		'@'		
UTC year	1	2	years	last two digits of UTC year	00	99
UTC month	3	2	months		01	12
UTC day	5	2	days		01	31
UTC hour	7	2	hours		00	23
UTC minute	9	2	minutes		00	59
UTC second	11	2	seconds		00	59
Latitude hemisphere	13	1		'N' = north		
				'S' = south		
Latitude degrees	14	2	degrees		0	90
Latitude minutes	16	5	0.001 minutes	minutes x 1000	0	59999
Longitude hemisphere	21	1		'E' = east		
				'W' = west		
Longitude degrees	22	3	degrees		0	180
Longitude minutes	25	5	0.001 minutes	minutes x 1000	0	59999
Position status	30	1		'g' = 2D GPS position		
				'G' = 3D GPS position		
				'd' = 2D diff GPS position		
				'D' = 3D diff GPS position		
				'S' = simulated position		
				'_' = invalid position		
Horizontal position error	31	3	meters		000	999
Altitude	34	6	meters	Height above/below MSL	-99999	+99999
East/west velocity direction	40	1		'E' = east		
				'W' = west		
East/west velocity magnitude	41	4	0.1 m/sec		0000	9999

Table 11-4 GPS Data Message Format

Field Name	Offset	Width	Units	Notes	Min	Max
North/south velocity direction	45	1		'N' = north		
				'S' = south		
North/south velocity magnitude	46	4	0.1 m/sec		0000	9999
Vertical velocity direction	50	1		'U' = up		
				'D' = down		
Vertical velocity magnitude	51	4	0.01 m/sec		0000	9999
CR/LF	55	2		0x0D/0x0A		
Total length	57					

APPENDIX A GAD 13 OAT PROBE INTERFACE MODULE INSTALLATION

This section contains general information as well as installation information for the optional GAD 13.

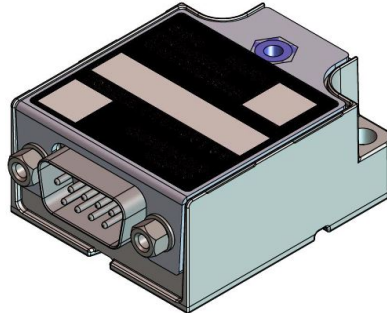

Figure A-1 GAD 13 Unit View

A.1 Equipment Description

The GAD 13 is a small unit used to interface to OAT (Outside Air Temperature) probes. The GAD 13 provides a standard three-wire or two-wire interface that can be connected to the following OAT probes:

- Garmin GTP 59
- AD590 based probes such as EDMO 655 and Davtron C307PS

OAT analog information from the GAD 13 is converted to digital information and passed to other G5 system LRUs using CAN communication. Addition of the GAD 13 enables the G5 to display TAS, OAT, and wind information. The GMU 11 magnetometer is required for wind information.

A.1.1 Equipment Available

The GAD 13 is available by the part numbers listed in Table A-1.

Table A-1 Available LRU Part Numbers

LRU	Assembly Part Number	Unit Only Part Number
GAD 13	010-02203-00	011-04938-00

A.1.2 Additional Equipment Required

The following accessories are not provided with the GAD 13 unit. The Connector Kit (Table A-2) is recommended to install the unit.

Table A-2 GAD 13, PMA Accessories

Item	Garmin P/N
Connector Kit, 9 Pin, w/CAN TERM, PMA	011-03002-10

Table A-3 Contents of Connector Kit (011-03002-10)

Item	Garmin P/N
Connector Kit, 9 Pin, w/CAN TERM	011-03002-00

Table A-4 Contents of Connector Kit (011-03002-00)

Item	Garmin P/N	Quantity
Sub-Assy, Backshell w/Hdw, Jackscrew, 9/15 pin	011-01855-00	1
Sub-Assy, CAN Termination Kit	011-02887-00	1
Connector, Rcpt, D-Sub, Crimp Socket, Commercial, 09 CKT	330-00625-09	1
Contact, Socket, Mil Crp, Size 20, 20-24 AWG, RoHS	336-00022-02	9

A.2 General Specifications

See Table A-5 for voltage/current specifications. See Table A-6 for dimension/weight specifications.

Table A-5 GAD 13 Power Requirements

14 V	28 V
50 mA Max*	120 mA Max*

*Includes GTP 59 Oat Probe

Table A-6 GAD 13 Physical Specifications

Width	Height	Depth*	Unit Weight	Weight of Unit and Connector Kit
1.43 in (36.2 mm)	0.79 in (20.0 mm)	1.85 in (47.1 mm)	0.14 lbs (0.064 kg)	0.25 lbs (0.113 kg)

*Harness connector not included

A.3 Mounting and Wiring Requirements

A.3.1 Unit Installation

The GAD 13 should be mounted to a surface known to have sufficient structural integrity to withstand additional inertial forces imposed by the weight of the unit.

In order to satisfy the structural mounting requirements for the GAD 13, the following conditions must be met:

1. The mounting structure, existing or new, must be electrically bonded to the airframe.
2. Any supporting structure must be rigidly connected to the aircraft primary structure through strong structural members capable of supporting substantial loads.
3. Mounting platform shall not span greater than 12" in width or length without direct attachment to primary structure. If mounting platform does span greater than 12", add necessary stringers, doublers, bulkhead flange reinforcements, etc., to provide adequate support. Existing honeycomb core sandwich panels with aluminum face sheets are adequate and do not require additional reinforcement.
4. A minimum of 3" between the GAD 13 connector end and any object must be maintained to ensure clearance for connectors and wire harness.
5. If a support bracket or shelf needs to be fabricated, it should be fabricated and attached to the aircraft structure in accordance with the methods outlined in AC43.13-2B Chapter 1 and 2, AC43.13-1B Chapter 4, and the following requirements:
 - a) Material shall be 2024-T3 aluminum alloy sheet per AMS-QQ-A-250/4 or Clad 2024-T3 aluminum alloy sheet per AMS-QQ-A-250/5.
 - b) The material shall be minimum 0.032 inch thick.
 - c) Material shall have some type of corrosion protection (primer, alodine, etc.)
 - d) It shall be attached to primary aircraft structure with a minimum of 4 fasteners listed in [Table A-7](#).

Table A-7 GAD 13 Mounting Hardware Used in Figure A-2

Hardware	Minimum Specifications
Screws	MS35206-XXX (#6-32, Length A/R)
Washers	NAS1149FN632P
Nuts	MS21042L06 or MS21044N06 OR Any Standard Mil-Spec Part Number #6 Nutplate (not available from Garmin)

Using the hardware called out in Table A-7, mount the GAD 13 to the chosen mounting location. Recommended torque of fasteners is 10 +/- 1 in-lbs.

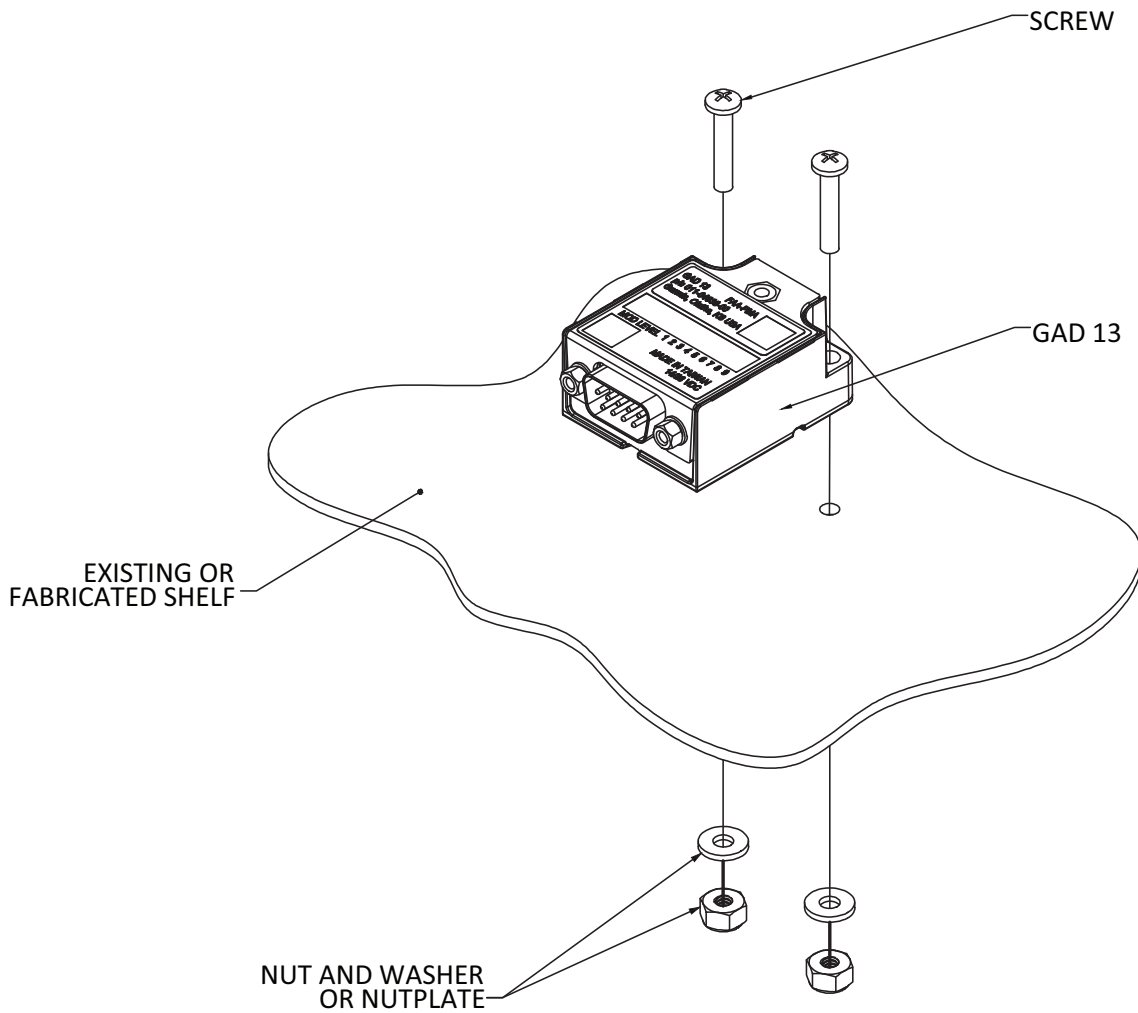

Figure A-2 GAD 13 Mounting Drawing

A.3.2 Wiring

The 9 pin connector, pins, and backshell supplied in the GAD 13 installation kit are used to add wiring for the GAD 13. See [Section 7](#) for interconnect drawings and Section A.4 for pinout information.

A.4 J131 Connector

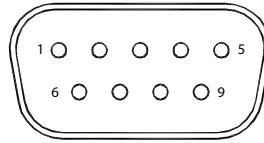

Figure A-3 J131 on GAD 13, as viewed looking at connector on unit

Table A-8. J131 Connector

Pin	Pin Name	I/O
1	CAN HI	I/O
2	CAN LO	I/O
3	GTP 59 IN HI	In
4	OAT PROBE IN	In
5	OAT PROBE OUT	Out
6	GTP 59 IN LO	In
7	AIRCRAFT POWER	In
8	GTP 59 POWER OUT	Out
9	POWER GROUND	--

A.4.1 Power

This section covers the power input requirements. The GAD 13 is compatible with 14V and 28V systems.

Table A-9. Power Pins

Pin Name	Connector	Pin	I/O
AIRCRAFT POWER	J131	7	In
POWER GROUND	J131	9	--

A.4.2 CAN Bus

The GAD 13 CAN bus conforms to the BOSCH standard for Controller Area Network (CAN) 2.0-B and ISO 11898. See [Section 2.2.2](#) for details. The CAN bus connection on the GAD 13 is used to connect the GAD 13 to one (or two) G5 units.

Table A-10. CAN Bus Pins

Pin Name	Connector	Pin	I/O
CAN HI	J131	1	I/O
CAN LO	J131	2	I/O

A.4.3 OAT Probe Interface

The GAD 13 has three pins (3, 6, 8) for interface to a passive (RTD type) probe and two pins (4, 5) for interface to an active OAT probe. This interface provides excitation voltage/current, and temperature sensing capabilities for an OAT probe. For specific wiring information, refer to [Figure 7-10](#).

Table A-11. OAT Probe Pins

Pin Name	Connector	Pin	I/O
GTP 59 IN HI	J131	3	In
GTP 59 IN LO	J131	6	In
GTP 59 POWER OUT	J131	8	Out
OAT PROBE IN	J131	4	In
OAT PROBE OUT	J131	5	Out

A.5 Outline and Installation Drawings

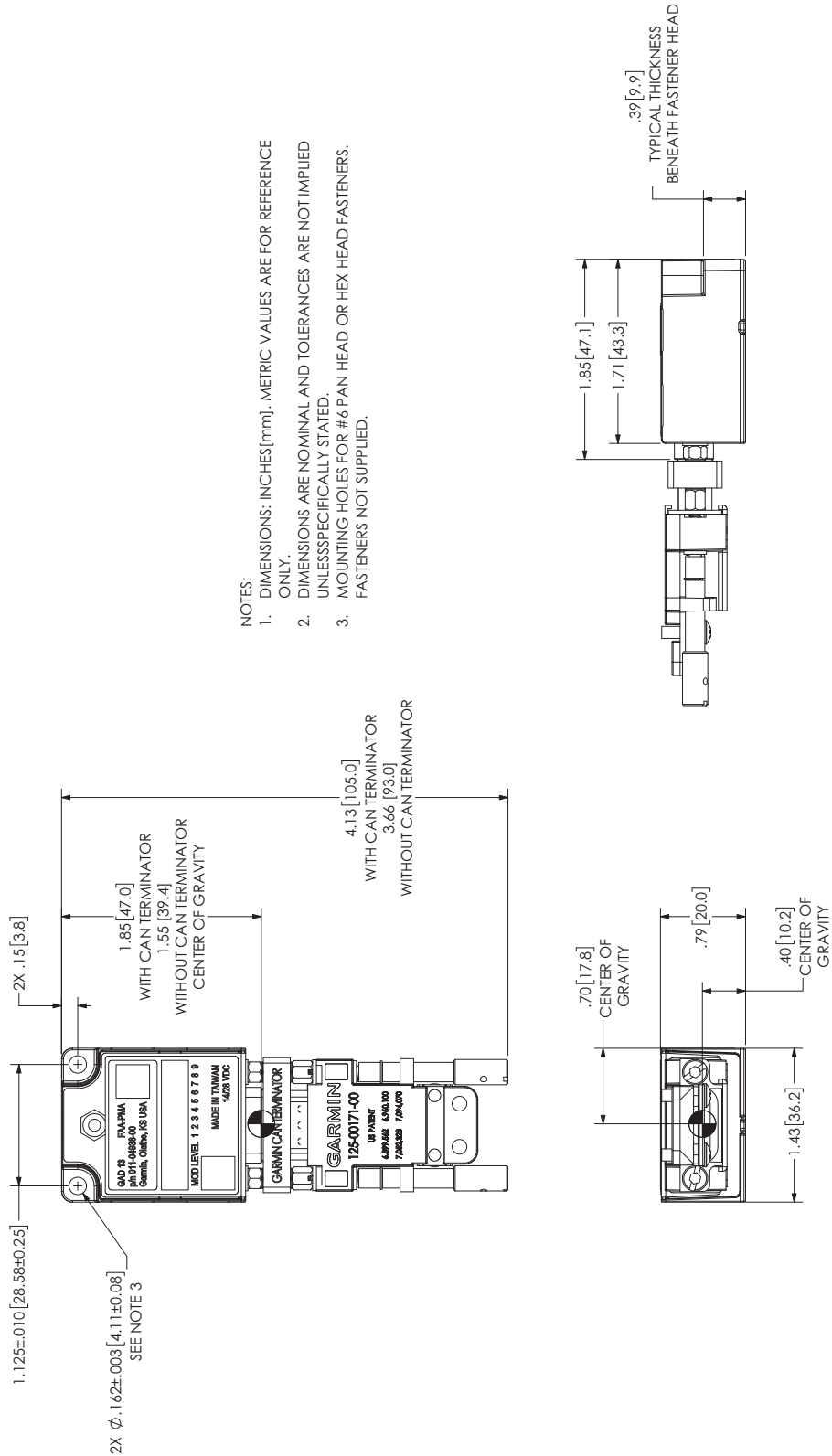

- NOTES:
1. DIMENSIONS: INCHES[mm]. METRIC VALUES ARE FOR REFERENCE ONLY.
 2. DIMENSIONS ARE NOMINAL AND TOLERANCES ARE NOT IMPLIED UNLESS SPECIFICALLY STATED.
 3. MOUNTING HOLES FOR #6 PAN HEAD OR HEX HEAD FASTENERS. FASTENERS NOT SUPPLIED.

Figure A-4 GAD 13 Outline Drawing

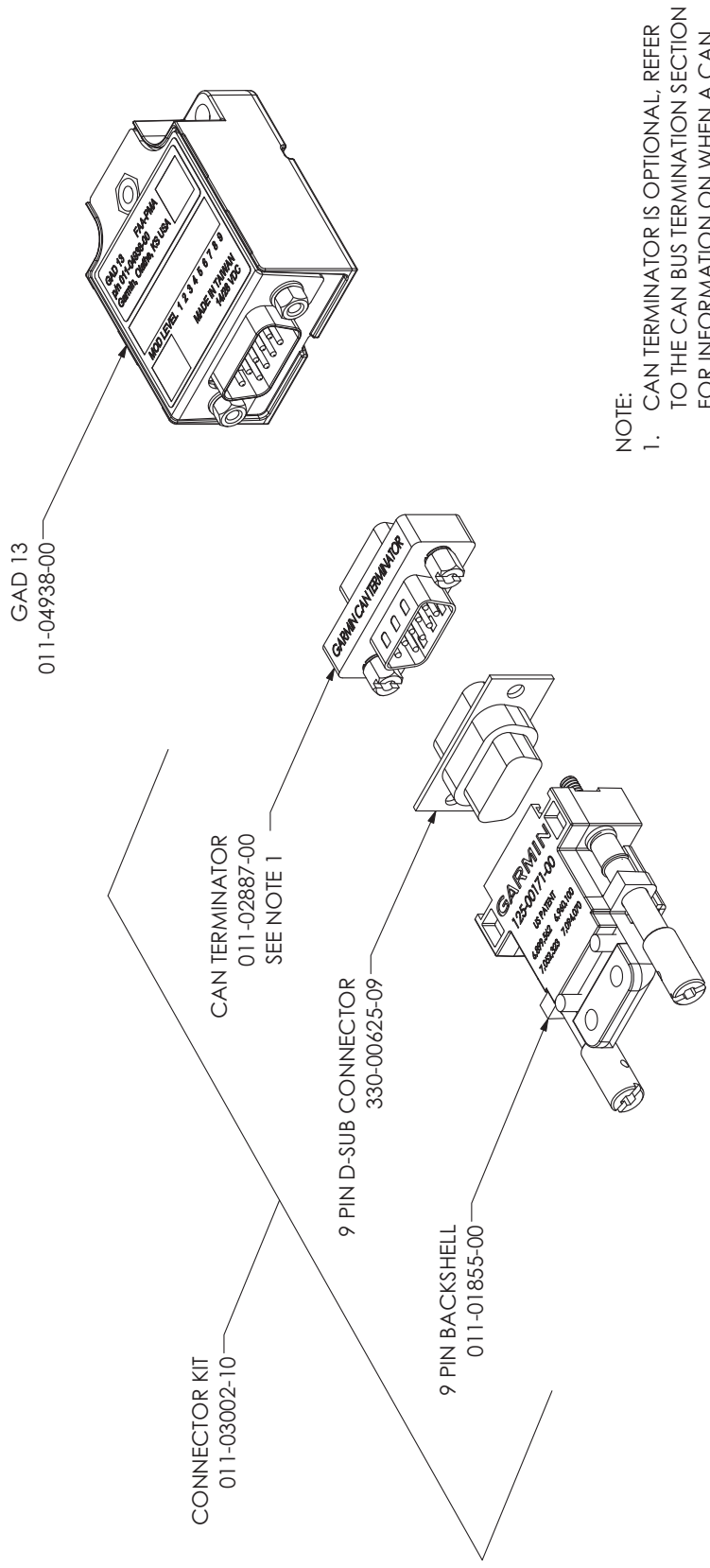

NOTE:
 1. CAN TERMINATOR IS OPTIONAL, REFER TO THE CAN BUS TERMINATION SECTION FOR INFORMATION ON WHEN A CAN TERMINATOR IS INSTALLED.

Figure A-5 GAD 13 Installation Drawing

APPENDIX B GAD 29/29B/29C/29D (ARINC 429 ADAPTER) INSTALLATION

This section contains general information as well as installation information for the GAD 29. Use this section to mount the GAD 29 unit.



NOTE

All information for the GAD 29 is also applicable to the GAD 29B/29C/29D unless explicitly noted.

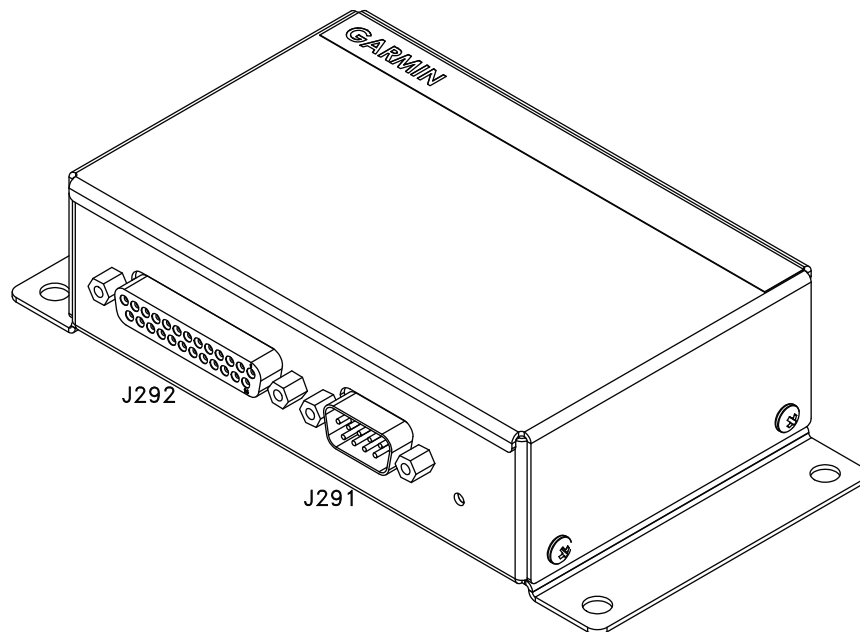

Figure B-1 GAD 29 Unit View

B.1 Equipment Description

The GAD 29 allows the G5 to interface to IFR navigators such as the GNC, GNS, GNX, GPS and GTN series. The GAD 29 has a 25 pin D-sub connector and a 9 pin D-sub connector. These connectors will provide the following functionality:

- 2 Low Speed ARINC 429 Transmitters
- 4 Low Speed ARINC 429 Receivers
- 1 CAN Network Port
- *Analog Outputs
- *Excitation Pass Through

*GAD 29B only

B.1.1 Status LED

The GAD 29 has an LED on its outer case that indicates its current status. See [Table 2-2](#) for details.

B.2 Equipment Available

B.2.1 Required Equipment

Table B-1 GAD 29 Part Numbers

Model	Assembly Part Number	Unit Only Part Number
GAD 29	010-01172-00	011-03236-00
GAD 29B	010-01172-10	011-03236-10
GAD 29C	010-01172-20	011-03236-20
GAD 29D	010-01172-21	011-03236-21

B.2.2 Additional Equipment Required

The connector kit in Table B-2 is required to install the unit, it is not provided with the GAD 29 unit.

Table B-2 Contents of GAD 29 Connector Kit (011-03271-00)

Item	Garmin P/N	Quantity
Backshell w/Hdw, Jackscrew, 9 Pin	011-01855-00	1
Backshell w/Hdw, Jackscrew, 25 Pin	011-01855-02	1
Conn, Plug,D-Sub, Crimp Pin, Commercial, 25 CKT	330-00624-25	1
Conn, Rcpt, D-Sub, Crimp Socket, Commercial, 09 CKT	330-00625-09	1
Contact, Socket, Military Crimp, Size 20	336-00022-02	11
Contact ,Pin, Military Crimp, Size 20	336-00024-00	27

B.3 General Specifications

See Table B-3 for voltage/current specifications. See Table B-4 for dimension/weight specifications.

Table B-3 GAD 29 Power Requirements

14 V	28 V
0.2 A Max	0.1 A Max

Table B-4 GAD 29 Physical Specifications

Width	Height	Depth*	Unit Weight	Weight of Unit and Connector Kit
6.10 in (154.9 mm)	1.48in (37.6 mm)	No Connector: 3.23 inches [82.0 mm] With Connector: 5.10 inches [129.4 mm] With Connector and CAN Terminator: 5.54 inches [140.7 mm]	0.38 lbs (0.17 kg)	0.63 lbs (0.29 kg)

B.4 Mounting and Wiring Requirements

The GAD 29 will mount remotely. The GAD 29 will be secured to the airframe using four screws supplied by the installer. Refer to [Section B.6](#) for outline and installation drawings.

B.4.1 Unit Installation

Sound mechanical and electrical methods and practices are recommended for installation of the GAD 29. Refer to [Section 2.2](#) for wiring considerations, and to [Section B.5](#) for pinouts.

1. Mount the unit to a suitable mounting location using (4) #10-32 pan or hex head screws.
2. Assemble the connector backshells and wiring harness.
3. Connect CAN terminator to unit if required ([Section 2.2.5](#)).
4. Connect backshell connectors.

B.4.2 Wiring

Fabrication of a wiring harness is required. The 9 and 25 pin connectors, pins, and backshells supplied in the GAD 29 connection kit ([Table B-2](#)) are used to add wiring for the GAD 29. See [Section 7](#) for interconnect drawings and [Section B.5](#) for pinout information.

B.5 Connector Pinout

B.5.1 J291 Connector

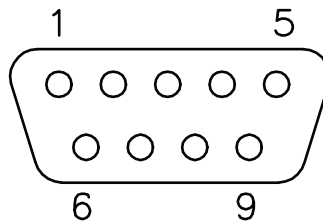

Figure B-2 J291 on GAD 29/29B, as viewed looking at connector on unit

Pin	Pin Name	I/O
1	CAN HI	I/O
2	CAN LO	I/O
3	RESERVED	--
4	RESERVED	--
5	RESERVED	--
6	GROUND	--
7	AIRCRAFT POWER 1	In
8	AIRCRAFT POWER 2	In
9	GROUND	--

B.5.2 J292 Connector

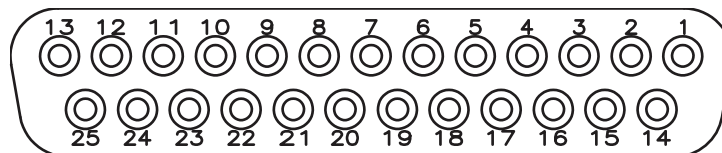

Figure B-3 J292 on GAD 29/29B, as viewed looking at connector on unit

Pin	Pin Name	I/O
1	RESERVED	--
	AC REFERENCE HI*	In
2	RESERVED	--
	AC REFERENCE LO*	In
3	RESERVED	--
	HDG/CRS VALID*	Out
4	ARINC RX 4B	In
5	ARINC RX 3B	In

*GAD 29B only

Pin	Pin Name	I/O
6	ARINC TX 2B	Out
7		
8	RESERVED	--
	HEADING ERROR HI*	Out
9	CAN TERM 1	--
10	ARINC RX 2B	In
11	ARINC RX 1B	In
12	ARINC TX 1B	Out
13		
14	GROUND	--
	HEADING ERROR LO*	In
15	RESERVED	--
	COURSE ERROR HI*	Out
16	ARINC RX 4A	In
17	ARINC RX 3A	In
18	ARINC TX 2A	Out
19		
20	GROUND	--
	COURSE ERROR LO*	In
21	CAN TERM 2	--
22	ARINC RX 2A	In
23	ARINC RX 1A	In
24	ARINC TX 1A	Out
25		

*GAD 29B only

B.5.3 Power

This section covers the power input requirements. AIRCRAFT POWER 1 and AIRCRAFT POWER 2 are “diode ORed” to provide power redundancy.

Pin Name	Connector	Pin	I/O
AIRCRAFT POWER 1	J291	7	In
AIRCRAFT POWER 2	J291	8	In
POWER GROUND	J291	6	--
POWER GROUND	J291	9	--

B.5.4 ARINC 429 RX/TX

The ARINC 429 outputs conform to ARINC 429 electrical specifications when loaded with up to 5 standard ARINC 429 receivers. Each ARINC 429 Transmitter pin is physically connected to two DSUB pins. When running one transmitter to two receivers use two separate pins to avoid splicing wires. Running one transmitter to more than two receivers will require splicing wires.

Pin	Connector	Pin Name	I/O
23	J292	ARINC RX 1A	In
11	J292	ARINC RX 1B	In
24	J292	ARINC TX 1A	Out
25	J292		
12	J292	ARINC TX 1B	Out
13	J292		
22	J292	ARINC RX 2A	In
10	J292	ARINC RX 2B	In
18	J292	ARINC TX 2A	Out
19	J292		
6	J292	ARINC TX 2B	Out
7	J292		
17	J292	ARINC RX 3A	In
5	J292	ARINC RX 3B	In
16	J292	ARINC RX 4A	In
4	J292	ARINC RX 4B	In

B.5.5 CAN Bus

The CAN Bus conforms to the BOSCH standard for Controller Area Network 2.0-B, and complies with ISO 11898. Pins 9 and 21 are used to terminate the CAN bus. To terminate the CAN bus at the GAD 29 short the pins (9 and 21) together. Refer to [Section 2.2.2](#) for details on configuring and terminating the CAN bus. The CAN bus on J291 shall be used for communications between LRUs.

Pin Name	Connector	Pin	I/O
CAN HI	J291	1	I/O
CAN LO	J291	2	I/O
CAN TERM 1	J292	9	--
CAN TERM 2	J292	21	--

B.5.6 Autopilot Heading/Course (GAD 29B only)

The GAD 29B can provide analog heading and course error outputs to non-Garmin analog autopilots. In the case of an AC autopilot, the GAD 29B has an AC REFERENCE signal input.

Pin Name	Connector	Pin	I/O
AC REFERENCE HI	J292	1	In
AC REFERENCE LO	J292	2	In
HDG/CRS VALID	J292	3	Out
HEADING ERROR HI	J292	8	Out
HEADING ERROR LO	J292	14	In
COURSE ERROR HI	J292	15	Out
COURSE ERROR LO	J292	20	Out

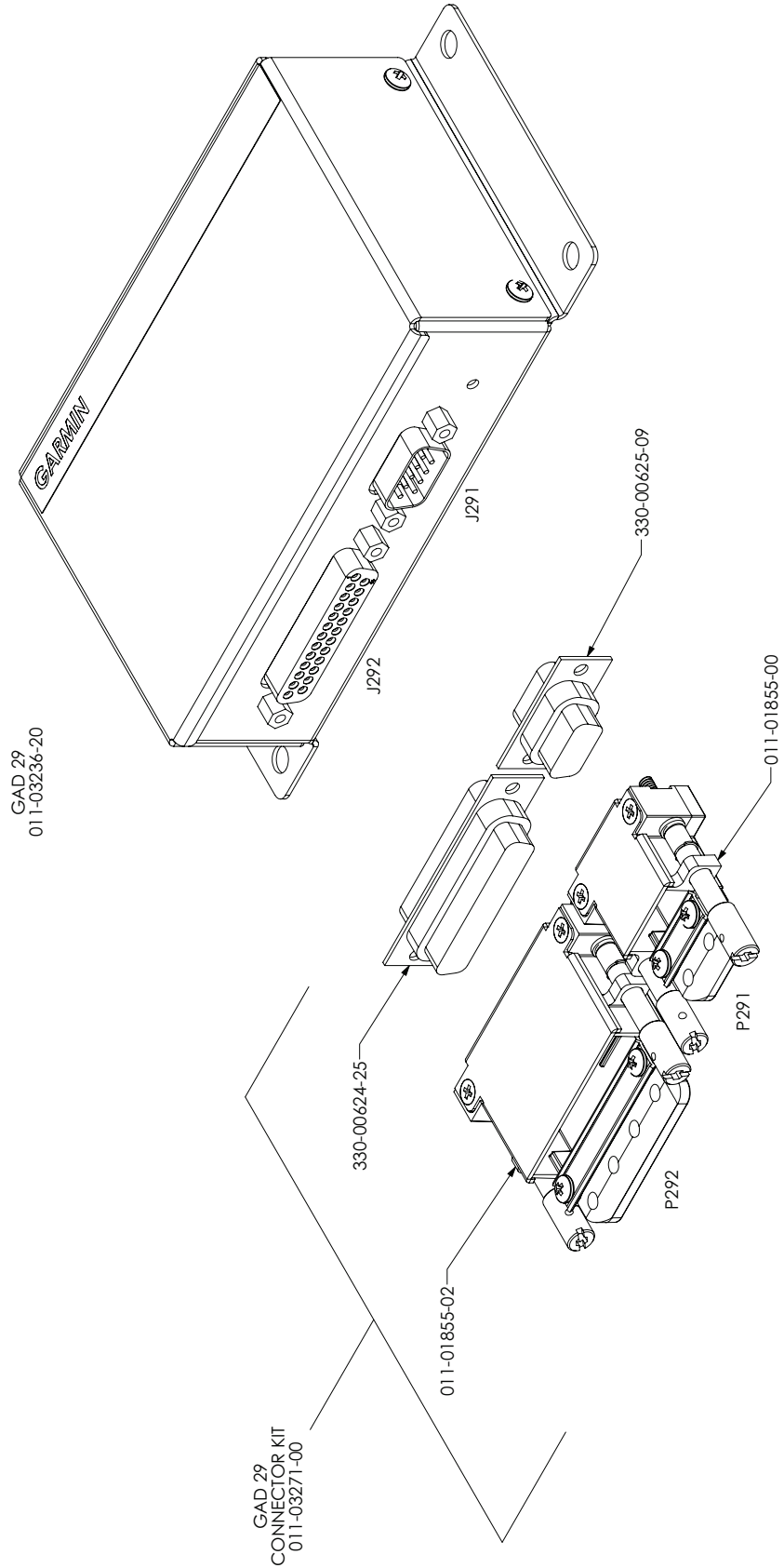

Figure B-5 GAD 29 Installation Drawing (no CAN terminator)

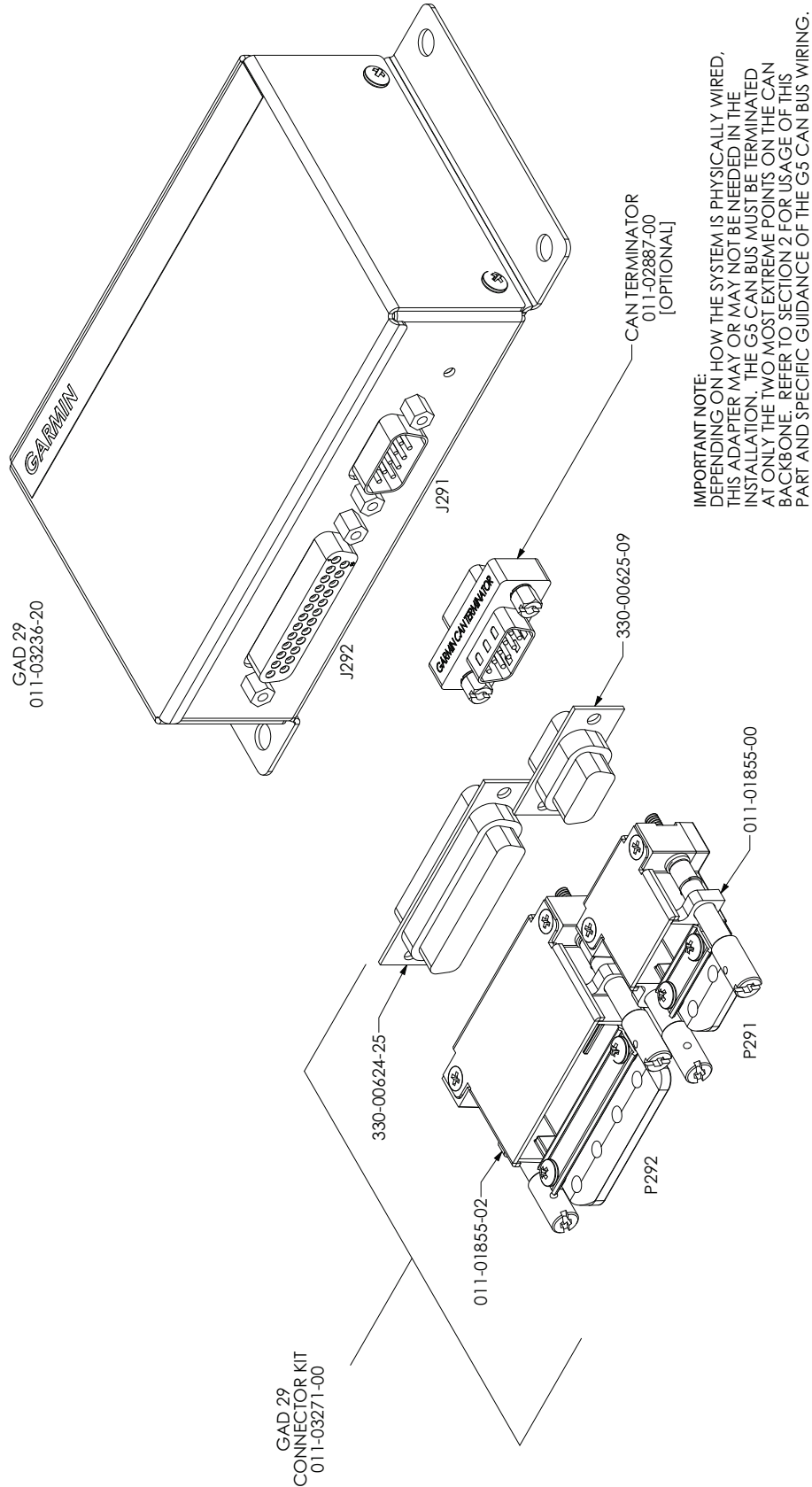

Figure B-6 GAD 29 Installation Drawing (with CAN terminator)

APPENDIX C GMC 507 (AFCS MODE CONTROLLER) INSTALLATION

This section contains general information as well as installation information for the optional GMC 507.

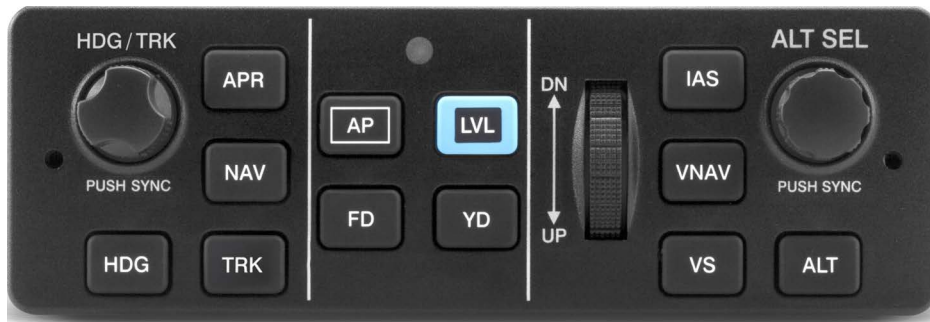

Figure C-1 GMC 507 Unit View (-00 version)

C.1 Equipment Description

The GMC 507 is a Garmin Automatic Flight Control System (AFCS) Mode Controller that can be used in a G5 autopilot installation. The GMC 507 provides a user interface for the autopilot function. The GMC 507 can be mounted to the aircraft instrument panel in a rectangular cutout or mounted using the optional installation rack ([Table C-3](#)).

C.1.1 Equipment Available

The GMC 507 is available by the part numbers listed in Table C-1.

Table C-1 Available LRU Part Numbers

LRU	Assembly Part Number	Unit Only Part Number
GMC 507	010-01946-00	011-04548-00

C.1.2 Additional Equipment Required

The following accessories are not provided with the GMC 507 unit. The Connector Kit (Table C-2) is required to install the unit.

Table C-2 Contents of Connector Kit (011-01824-01)

Item	Garmin P/N	Quantity
Backshell w/Hdw, Jackscrew, 9/15 Pin	011-01855-00	1
Connector, Male, High Density D-Sub, 15 CKT	330-00366-15	1
Contact, Pin, Military Crimp, Size 22D	336-00021-00	15

C.1.3 Optional Equipment

Table C-3 GMC 507 Installation Rack Kit (010-12700-10)

Item	Garmin P/N	Quantity
GMC 507 Installation Rack	115-02774-00	1

C.2 General Specifications

See Table C-4 for power/current specifications. See Table C-5 and the drawings in [Section C.5](#) for dimension/weight specifications.

Table C-4 GMC 507 Power Requirements

14 V (Maximum)	14 V (Typical)	28 V (Maximum)	28 V (Typical)
0.20 A, 2.8 W	0.11 A, 1.54 W	0.11 A, 3.08 W	.06 A, 1.68 W

Table C-5 GMC 507 Physical Specifications

Width	Height	Depth*	Unit Weight	Weight of Unit and Connector Kit
6.25 in (158.8 mm)	2.10 in (53.3 mm)	2.61 in (66.3 mm)	0.68 lbs (0.308 kg)	0.78 lbs (0.354 kg)

*Harness connector not included

C.3 Mounting and Wiring Requirements

C.3.1 Panel Cutout Template

[Figure C-7](#) can be used as a template when marking the panel for cutout. Dimensions on the figure are to verify accuracy of printout only, see [Figure C-6](#) for complete cutout dimensions. A .dxf version of the drawing is also available for download at <https://support.garmin.com/support/manuals>.



CAUTION

Exercise caution when installing the rack in the instrument panel. Deformation of the rack will make it difficult to install and remove the GMC 507.



NOTE

If the front edges of the installation rack are behind the front surface of the aircraft panel, the GMC 507 pawl latches may not fully engage.



NOTE

The GMC 507 install rack may be used as a template for drilling the mounting holes.

C.3.2 Unit Installation

Fabrication of a wiring harness is required. Sound mechanical and electrical methods and practices are recommended for installation of the GMC 507. Refer to [Section 2.2](#) for wiring considerations, and to [Appendix C.4](#) for pinouts.

C.3.2.1 Panel Cutout Installation

1. Per Figure C-2, ensure the pawl latch fasteners are fully retracted and in the vertical position.
2. Insert the unit into the instrument panel cutout so that the backside of the bezel rests against the instrument panel. Orient the install rack as shown in [Figure C-9](#).
3. Using a 3/32" hex drive tool turn each of the two pawl latches clockwise until tightened to 20 +/-2 in-lbs. When tightened, the pawl latches are in the horizontal position (see [Figure C-2](#)).

C.3.2.2 Radio Stack Installation

The GMC 507 Install Rack (115-02774-00) is to be used when installing the GMC 507 unit into a radio stack. [Figure C-10](#) shows the various radio stack cutout configurations that will accommodate the Install Rack.

1. Ensure the left and right front edges of the install rack are flush with the front surface of the instrument panel.
2. Secure the install rack to a rigid, primary aircraft structure using (qty. 4) #6 100° flat head machine screws as noted in [Figure C-8](#). The screws are inserted from the inside of the installation rack and may be secured using self-locking hex nuts on the outside.
3. With the pawl latch fasteners retracted, insert the GMC 507 into the Install Rack until the bezel contacts the front edges of the Install Rack.
4. Using a 3/32" hex drive tool turn each of the two pawl latches clockwise until tightened to 20 +/-2 in-lbs. When tightened, the pawl latches are in the horizontal position (see [Figure C-2](#)).



CAUTION

To remove the GMC from the instrument panel, turn each of the two pawl latches counterclockwise, not exceeding 15 in-lbs of torque.

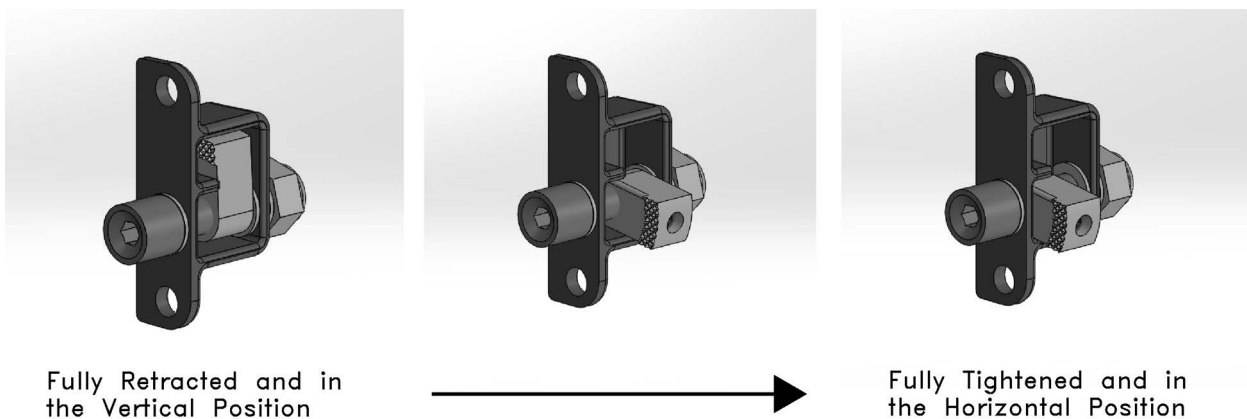

Figure C-2. Pawl Latch

C.3.3 Wiring

The 15 pin connector, pins, and backshell supplied in the GMC 507 installation kit are used to add wiring for the GMC 507. See [Section 7](#) for interconnect drawings and [Section C.4](#) for pinout information.

C.4 J7001 Connector

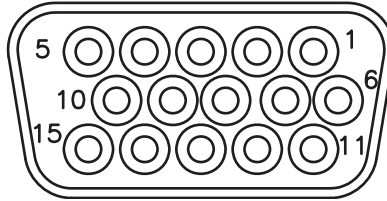

Figure C-3 J7001 on GMC 507, as viewed looking at connector on unit

Pin	Pin Name	I/O
1	RESERVED	--
2	RESERVED	--
3	CAN HI	I/O
4	CAN LO	I/O
5	SONALERT	Out
6	CAN BUS TERM 2	--
7	AIRCRAFT POWER 1	In
8	CAN BUS TERM 1	--
9	AIRCRAFT POWER 2	In
10	TO/GA DISCRETE IN	In
11	LIGHTING BUS HI	In
12	AP DISCONNECT IN/OUT	I/O
13	AUDIO HI	Out
14	AUDIO LO	Out
15	POWER GROUND	--

C.4.1 Power

This section covers the power input requirements. The GMC 507 is compatible with 14V and 28V systems. AIRCRAFT POWER 1 and AIRCRAFT POWER 2 are “diode ORed” to provide power redundancy.

Pin Name	Connector	Pin	I/O
AIRCRAFT POWER 1	J7001	7	In
AIRCRAFT POWER 2	J7001	9	In
POWER GROUND	J7001	15	--

C.4.2 CAN Bus

The G5 CAN bus conforms to the BOSCH standard for Controller Area Network 2.0-B and ISO 11898. See [Section 2.2.2](#) for details. To enable the internal CAN terminator when the GMC 507 is installed at one of the two ends of the CAN bus, a wire must be installed to short pin 6 to pin 8.

Pin Name	Connector	Pin	I/O
CAN HI	J7001	3	I/O
CAN LO	J7001	4	I/O
CAN BUS TERM 1	J7001	8	--
CAN BUS TERM 2	J7001	6	--

C.4.3 Lighting

The GMC 507 supports two internal backlighting buses, one for the mode (indicator) lights above the buttons, and one for the button text, panel text, and knob backlighting.

Mode Indicator Backlighting - The lighting level for the mode lights (indicator triangles) above the buttons is controlled by the photocell only, and is not affected by the lighting bus input (pin 11). This ensures that the mode selection lights on the panel are always visible (and are independent of the externally applied lighting bus).

Button Text, Panel Text, and Knob Backlighting - The GMC 507 can be installed to use either the built-in photocell or the 14-28V lighting bus input for backlight control of the button text, panel text, and knob backlighting. The photocell controls all backlighting when the lighting bus input is below 1.4VDC (or unconnected). If the lighting bus input voltage is greater than 1.4VDC, the GMC 507 uses the lighting bus input voltage (1.4VDC-28.0VDC range) as a reference voltage (not power source) to adjust the backlighting for these items.

Pin Name	Connector	Pin	I/O
LIGHTING BUS HI	J7001	11	In

C.4.4 Audio Out

Audio output provides an autopilot disconnect tone and other aural alerts. Connect this output to an unused audio alert input on an audio panel.

Pin Name	Connector	Pin	I/O
AUDIO HI	J7001	13	Out
AUDIO LO	J7001	14	

C.4.5 Sonalert

May be connected to a Sonalert when an audio panel is not available to use with the audio output.

Pin Name	Connector	Pin	I/O
SONALERT	J7001	5	Out

C.4.6 TO/GA Discrete In

Provides an active low discrete input which may optionally be connected to a TO/GA button.

Pin Name	Connector	Pin	I/O
DISCRETE IN	J7001	10	In

C.4.7 AP Disconnect In/Out

This pin is used for certified installations only.

Pin Name	Connector	Pin	I/O
AP DISCONNECT IN/OUT	J7001	12	I/O

C.5 Outline and Installation Drawings

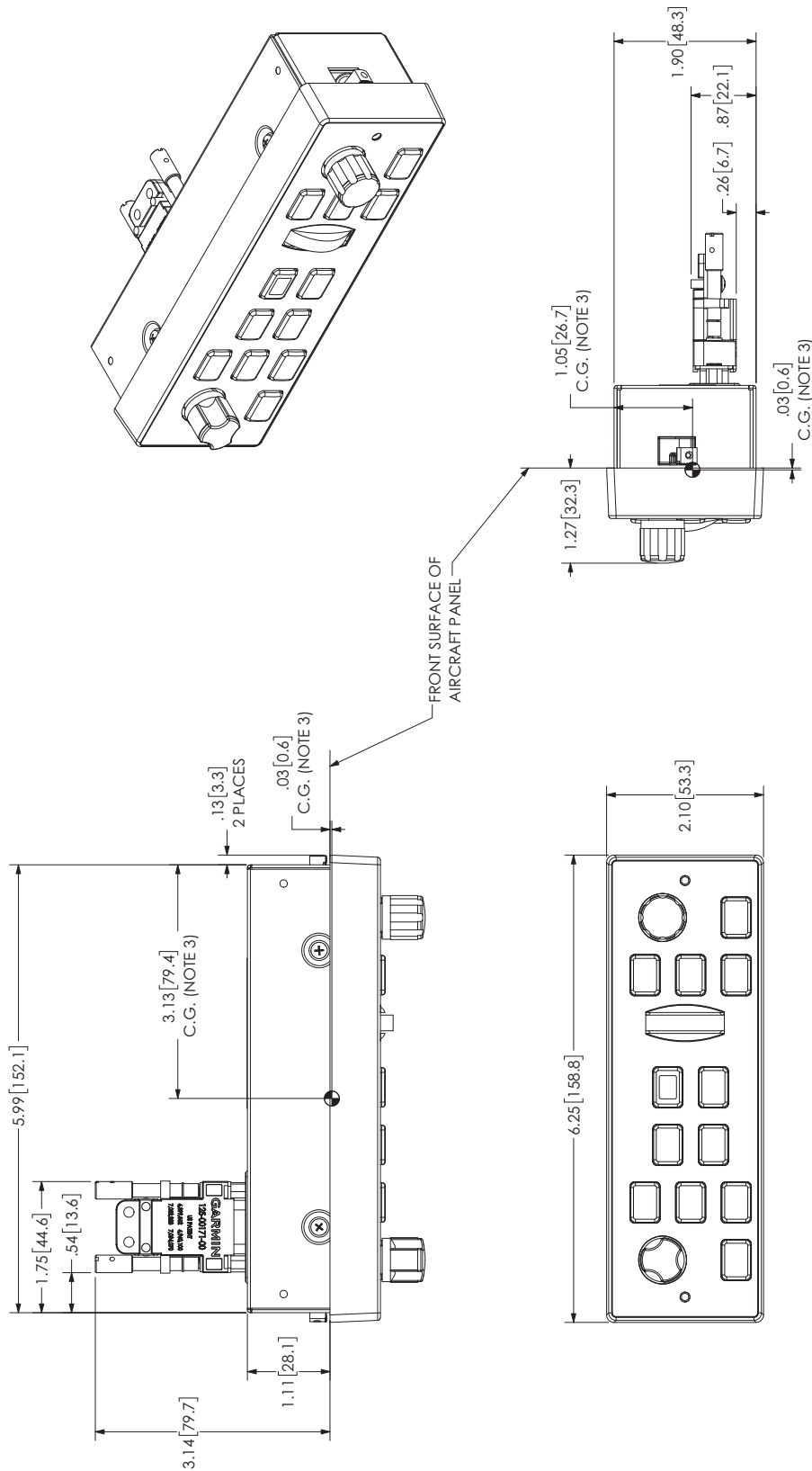

Figure C-4 GMC 507 Outline Drawing (no installation rack)

- NOTES:
1. DIMENSIONS: INCHES [mm]. METRIC VALUES ARE FOR REFERENCE ONLY.
 2. DIMENSIONS ARE NOMINAL AND TOLERANCES ARE NOT IMPLIED UNLESS SPECIFICALLY STATED.
 3. CENTER OF GRAVITY (C.G.) LOCATION IS WITHOUT CONNECTOR KIT INSTALLED.

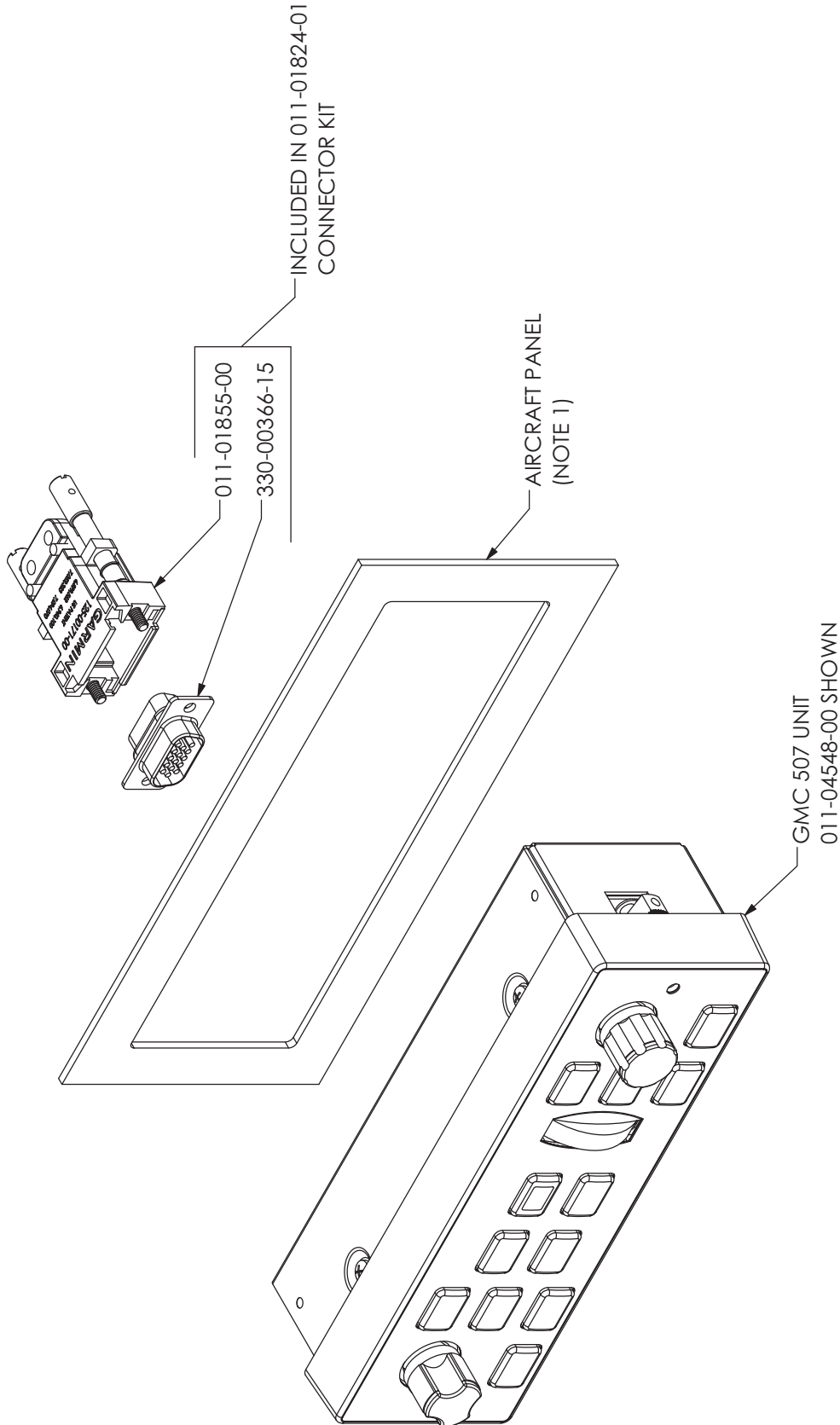

Figure C-5 GMC 507 Installation Drawing (no installation rack)

INSTALLATION NOTES:

1. THE PAWL LATCH FASTENERS WILL ACCOMMODATE PANEL THICKNESSES FROM .075[1.91] TO .140[3.56] THICK AND REQUIRE NO ADDITIONAL MOUNTING HARDWARE.
2. THE FASTENERS ARE ENGAGED AND DISENGAGED BY USE OF A 3/32" HEX TOOL.
3. TORQUE FASTENERS TO 20±2 IN-LBS ON INSTALLATION.
4. TO DISENGAGE THE UNIT, ROTATE FASTENERS CCW. DO NOT EXCEED 15 IN-LBS OF TORQUE.

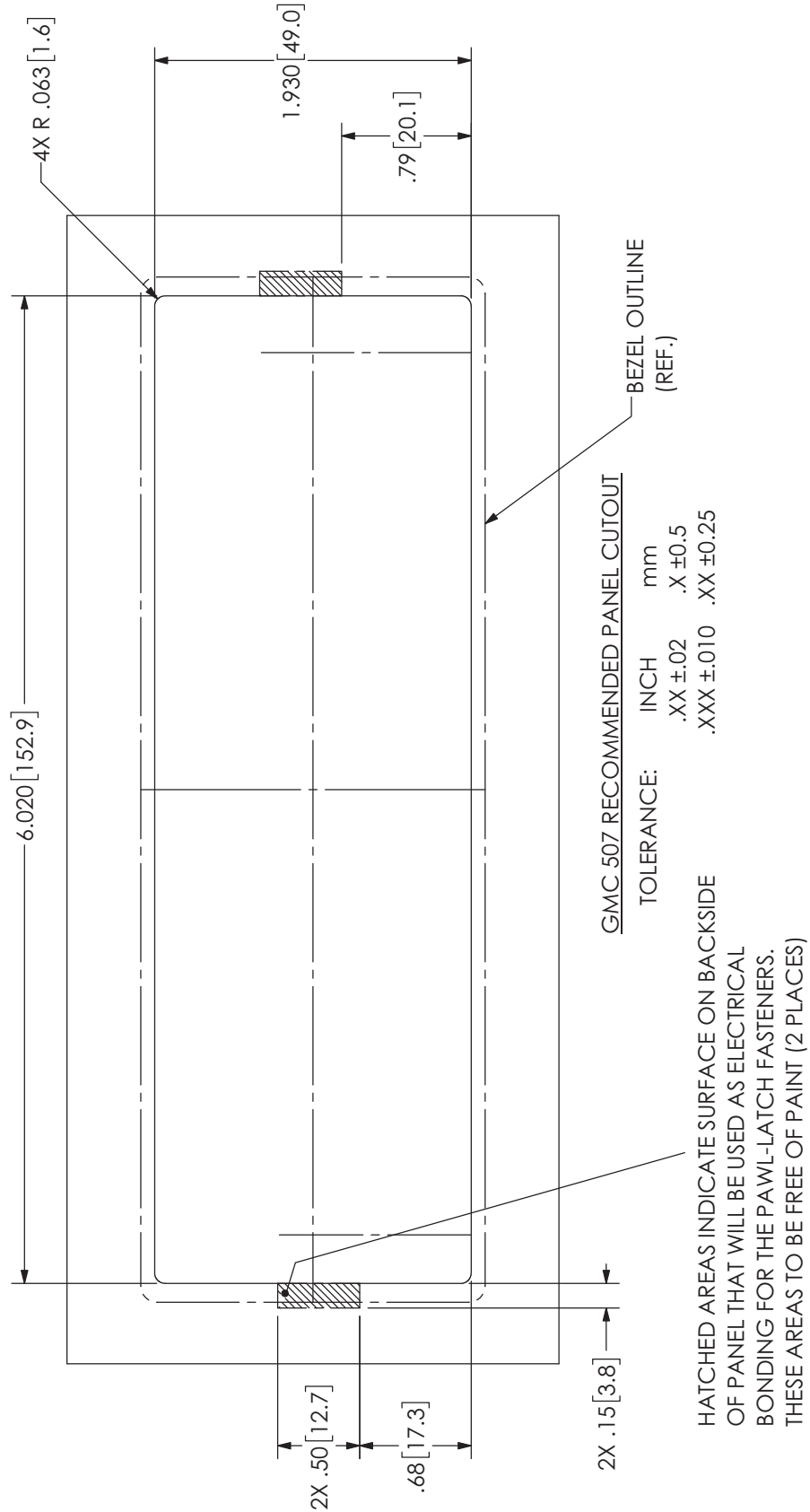
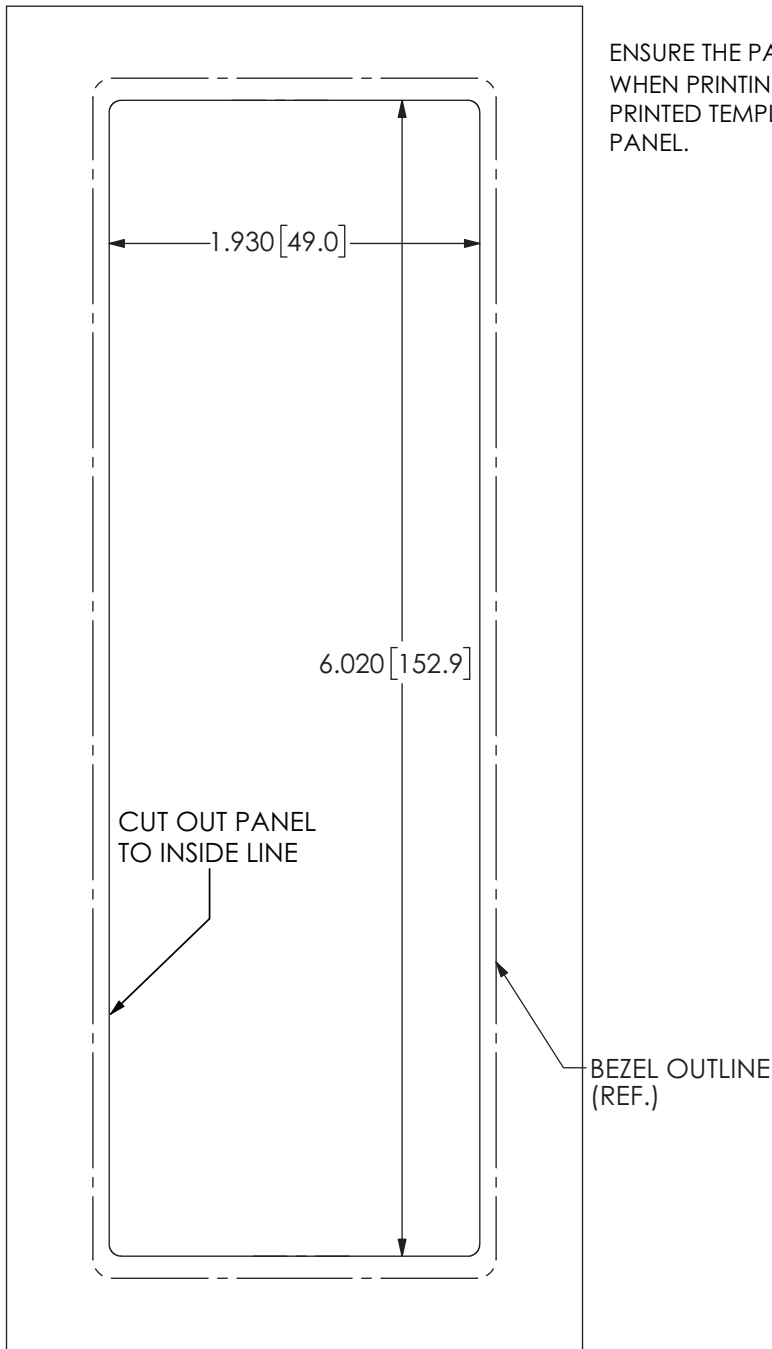

Figure C-6 GMC 507 Cutout Drawing, No Installation Rack (Not to Scale)

GMC 507 PANEL CUTOUT



IMPORTANT!

ENSURE THE PAGE SCALING SETTING IS SET TO NONE WHEN PRINTING THIS PAGE. VERIFY DIMENSIONS OF PRINTED TEMPLATE ARE ACCURATE BEFORE CUTTING PANEL.

NOTES:

1. DIMENSIONS: INCHES [mm]. METRIC VALUES ARE FOR REFERENCE ONLY.
2. TOLERANCES:

.XX ±.02	mm
.XXX ±.010	.X ±0.5
	.XX ±0.25

Figure C-7 GMC 507 Panel Cutout Template (no installation rack)

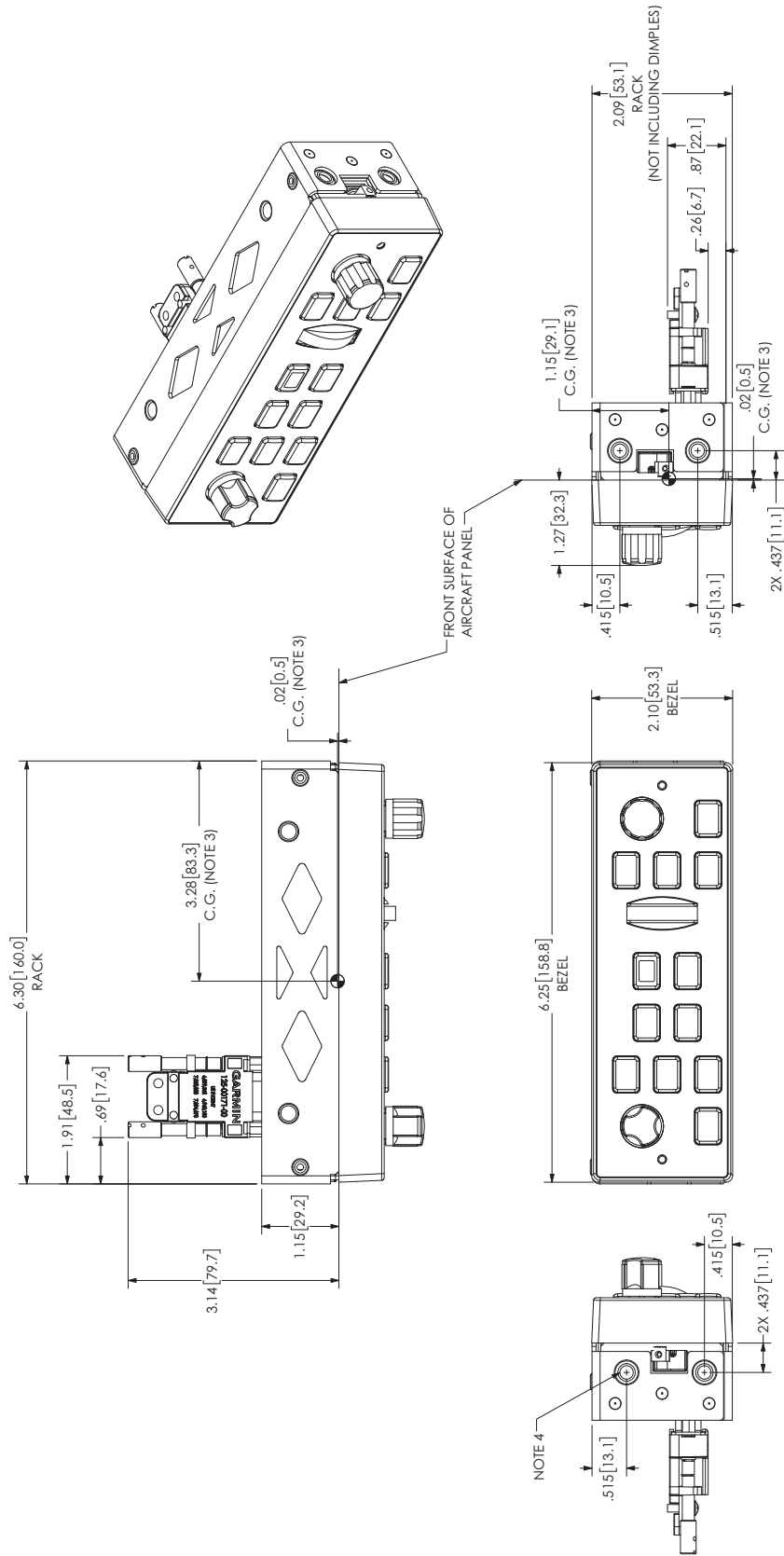

- NOTES:
1. DIMENSIONS: INCHES[mm]. METRIC VALUES ARE FOR REFERENCE ONLY.
 2. DIMENSIONS ARE NOMINAL AND TOLERANCES ARE NOT IMPLIED UNLESS SPECIFICALLY STATED.
 3. CENTER OF GRAVITY (C.G.) LOCATION IS WITHOUT CONNECTOR KIT INSTALLED.
 4. MOUNTING HOLES ARE FOR #6 FLAT HEAD 100° CSK SCREWS (4 PLACES)

Figure C-8 GMC 507 Outline Drawing with Installation Rack

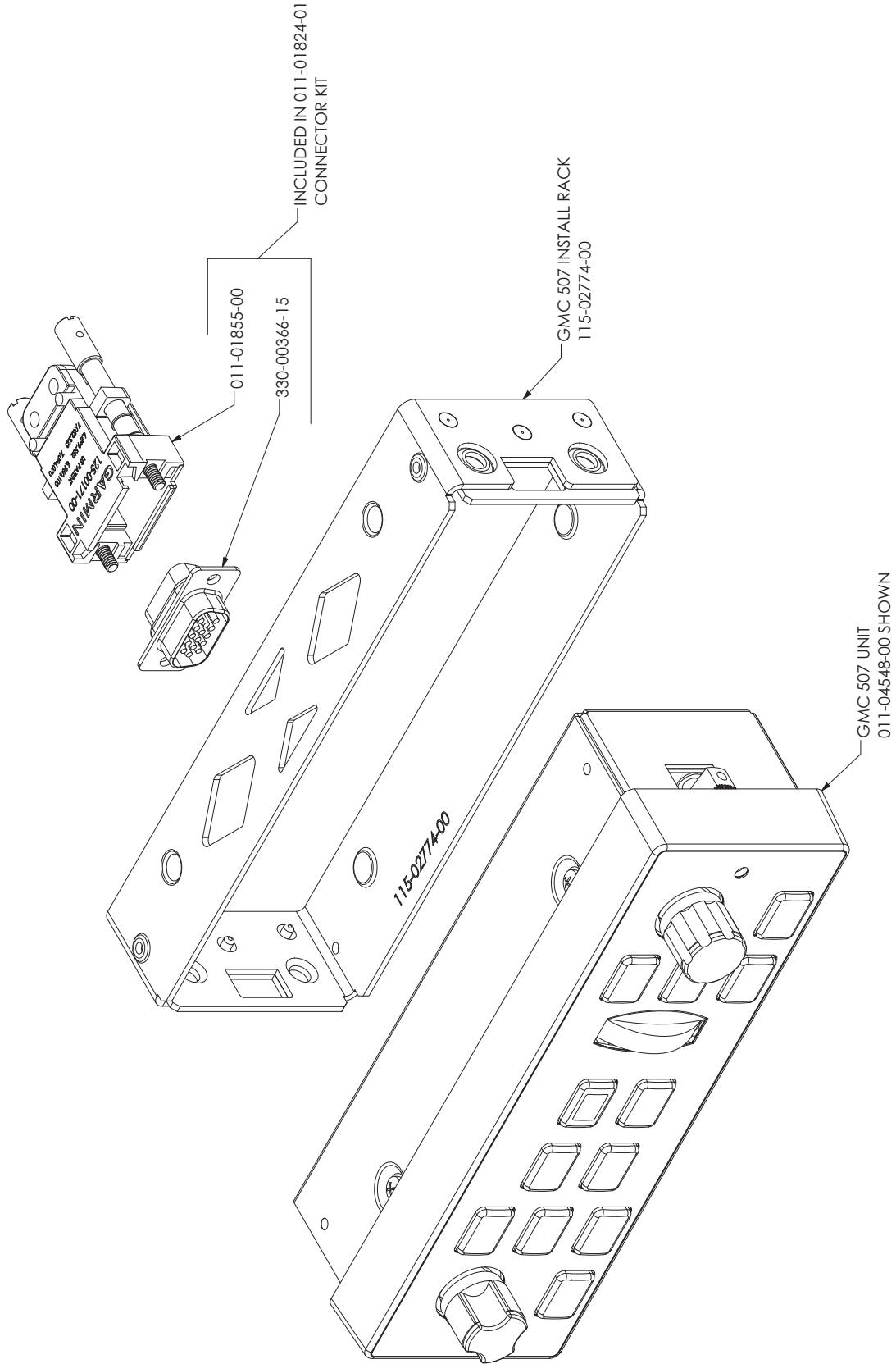

- NOTES:
1. THE FASTENERS ARE ENGAGED AND DISENGAGED BY USE OF A 3/32" HEX TOOL.
 2. TORQUE FASTENERS TO 20±2 IN-LBS ON INSTALLATION.
 3. TO DISENGAGE THE UNIT, ROTATE FASTENERS CCW. DO NOT EXCEED 15 IN-LBS OF TORQUE.

Figure C-9 GMC 507 Installation Drawing with Installation Rack

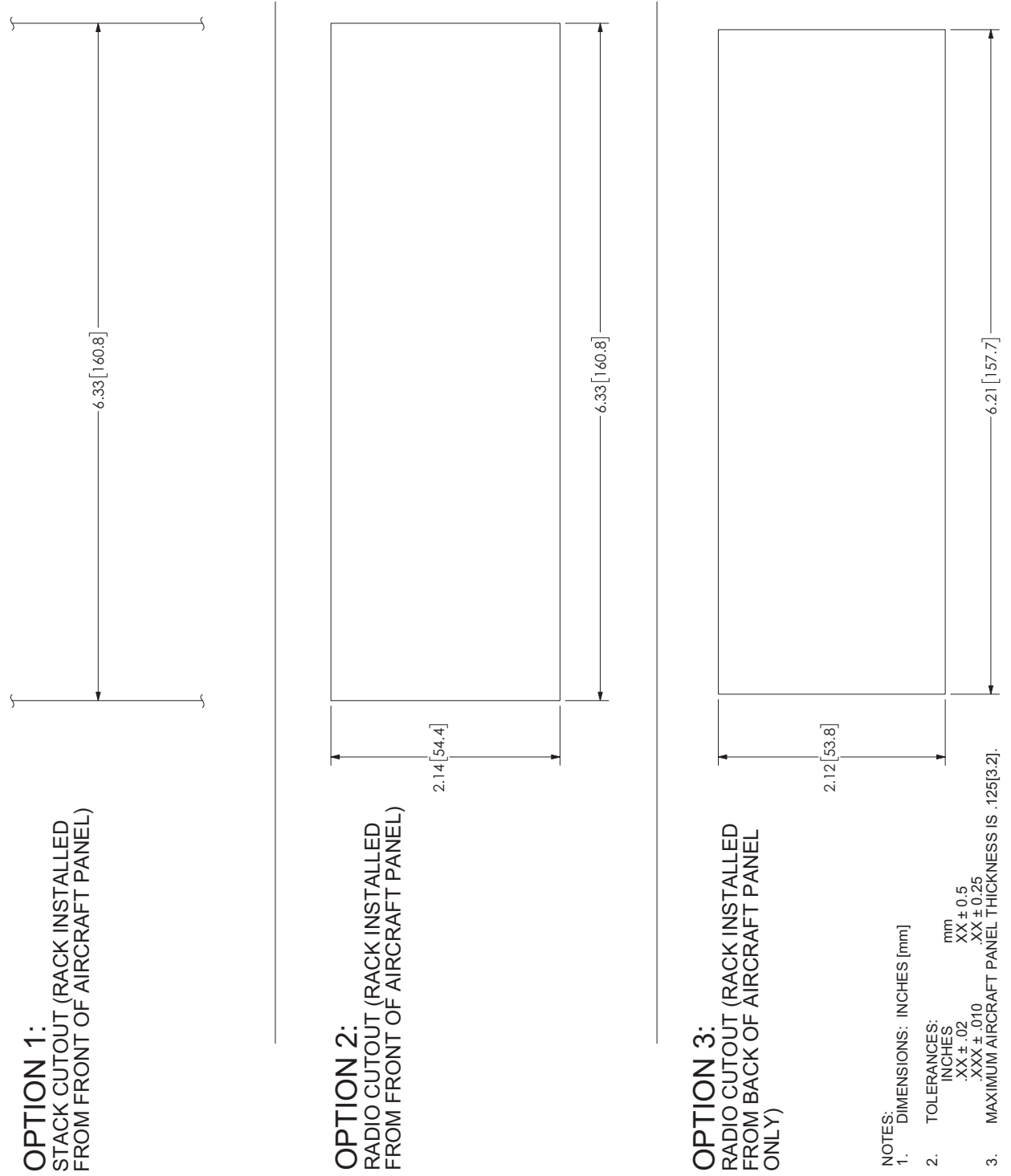

Figure C-10 GMC 507 Panel Cutout Template for Installation with Installation Rack

APPENDIX D GMU 11 (MAGNETOMETER) INSTALLATION

This section contains general information as well as installation information for the GMU 11. Use this section to mount the GMU 11 unit.

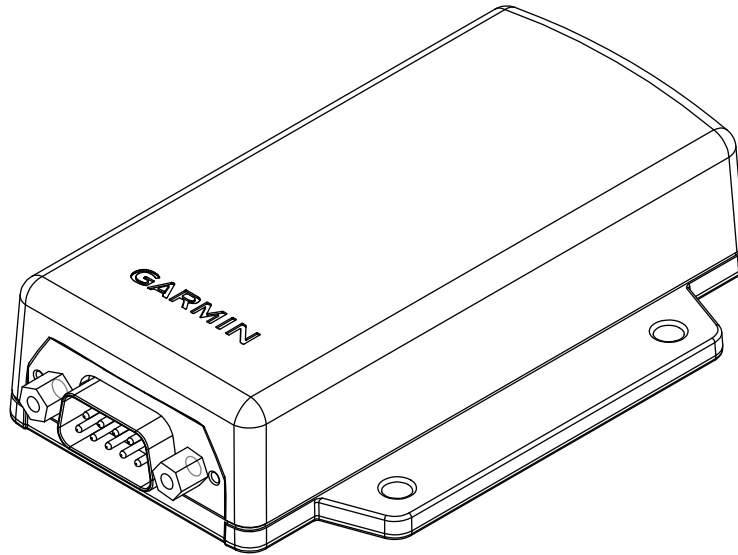

Figure D-1 GMU 11 Unit View

D.1 Equipment Description

The GMU 11 magnetometer is a remote mounted device that provides magnetometer data to a Garmin G5. The Garmin ADAHRS and magnetometer replace traditional rotating mass instruments.

An Attitude and Heading Reference System combines the functions of a Vertical Gyro and a Directional Gyro to provide measurement of Roll, Pitch, and Heading angles. The Garmin ADAHRS and magnetometer replace traditional rotating mass instruments.

Using long-life solid-state sensing technology, the GMU 11 Magnetometer uses magnetic field measurements to create an electronically stabilized AHRS.

The GMU 11 magnetometer provides magnetic information to support the AHRS function of the G5. The supply voltage for the GMU 11 Magnetometer comes from aircraft power (9-32 V 100mA.)

D.2 Equipment Available

Table D-1 GMU 11 Part Numbers

Model	Assembly Part Number	Unit Only Part Number	Installation Rack
GMU 11	010-01788-00	011-04349-00	No

Table D-2 GMU 11 Accessories

Item	Garmin P/N	Quantity
GMU 11, Installation Kit	011-04349-90	1

Table D-3 Contents of GMU 11 Installation Kit (011-04349-90)

Item	Garmin P/N	Quantity
Connector Kit, 9 Pin, w/CAN Term	011-03002-00	1
Nut, Hex, Nyl Locking, 316SS/P, 6-32	210-10008-08	4
Screw, 6-32x.500, PHP, SS/P	211-60207-12	4
Washer, Flat, SAE, SS, #6	212-00024-06	4

D.3 General Specifications

See Table D-4 for voltage/current specifications. See Table D-5 for dimension/weight specifications.

Table D-4 GMU 11 Power Requirements

14 V	28 V
0.10 A Max	0.10 A Max

Table D-5 GMU 11 Physical Specifications

Width	Height	Depth*	Unit Weight	Weight of Unit and Connector Kit
2.74 in (6.96 mm)	0.93in (2.36 mm)	3.78 inches [9.60 mm]	0.16 lbs (0.0725 kg)	0.302 lbs (0.1368 kg)

D.4 Unit Installation

The following guidelines describe proper mechanical installation of the Garmin GMU 11 Magnetometer. The guidelines include requirements for proper location selection in the aircraft, requirements for supporting structure and mechanical alignment and restriction on nearby equipment.

Fabrication of a wiring harness is required. Sound mechanical and electrical methods and practices are required for installation of the GMU 11. Refer to [Section 2.2](#) for wiring considerations and to [Section D.5](#) for pinouts.

The GMU 11 is an extremely sensitive three-axis magnetic sensor. It is more sensitive to nearby magnetic disturbances than a flux gate magnetometer. For this reason, when choosing a mounting location for the GMU 11, observe the following distances from objects or devices that can disturb the magnetic field. [Table D-6](#) specifies recommended distances from magnetic disturbances for GMU 11 location.



NOTE

If the requirements listed in [Table D-6](#) cannot be met, a magnetometer interference test must be performed to ensure proper operation of the G5. Refer to the AHRS/ Magnetometer Installation Considerations document (190-01051-00) available from the Garmin website (www.flygarmin.com).

Table D-6 Recommended Distance from Magnetic Disturbances

Disturbance Source*	Minimum Distance from GMU 11
Electric motors and relays, including servo motors	10 feet (3.0 meters)
Ferromagnetic structure greater than 1 kg total (iron, steel, or cobalt materials, especially landing gear structure)	8.2 feet (2.5 meters)
Ferromagnetic materials less than 1 kg total, such as control cables	3 feet (1.0 meter)
Any electrical device drawing more than 100 mA current	3 feet (1.0 meter)
Electrical conductors passing more than 100 mA current [(should be twisted shielded pair if within 10 feet (3.0 meters))]	3 feet (1.0 meter)
Electrical devices drawing less than 100 mA current	2 feet (0.6 meter)
Magnetic measuring device other than another GMU 11 (e.g. installed flux gates, even if not powered)	2 feet (0.6 meter)
Electrical conductors passing less than 100 mA current [(should be twisted shielded pair if within 10 feet (3.0 meters))]	1.3 feet (0.4 meter)

*Disturbance sources listed in table do not apply to a second installed GMU 11

Ensure that any electrical conductor that comes within 10 feet (3.0 meters) of the GMU 11 is installed as a twisted shielded pair, not a single-wire conductor. (If possible, the shield should be grounded at both ends.)

Use nonmagnetic materials to mount the GMU 11, and replace any magnetic fasteners within 0.5 meter with nonmagnetic equivalents (e.g. replace zinc-plated steel screws used to mount wing covers or wing tips with nonmagnetic stainless steel screws).

In general, wing mounting of the GMU 11 magnetometer is preferred. Fuselage mounting is less desirable because of numerous potential disturbances that interfere with accurate operation. For installations with dual GMU 11 magnetometers, co-locating the two magnetometers close to each other in the tail or in one wing is recommended as this reduces the likelihood of heading splits or miscompares when operating on the ground in the vicinity of local magnetic anomalies.

Mechanical mounting fixtures for the GMU 11 must be rigidly connected to the aircraft structure. Use of typical aircraft-grade non-magnetic materials and methods for rigid mounting of components is acceptable, so long as adequate measures are taken to ensure a stiffened mounting structure.

Level the GMU 11 to within 3.0° of the in-flight level cruise attitude.

Per [Figure D-5](#), align the GMU 11's forward direction to within 0.5° of the any of the 4 cardinal directions with relation between its connector and the nose of the aircraft. Make sure that the bottom of the unit is facing downwards (towards earth) per [Figure D-5](#).

D.4.1 Consideration for Wing Grounded Lighting Fixtures

The following installation practices are recommended if the GMU 11 is mounted in the wing.

The wing tip lights should not have a power ground referenced to the chassis of the light assembly that would then be referenced back to the airframe ground via the light assembly mounting.

A dedicated power ground should be used and returned as a twisted pair with the power source back into the fuselage for a wing mounted GMU 11.

These installation practices will prevent magnetically interfering currents from flowing in the wing skin that encloses the GMU 11. Electrically isolating the light assembly should not be used as an alternative to the preceding consideration, unless the isolated light assembly has been analyzed for adequate protection against direct attachment of lightning.

Refer to [Section D.6](#) for outline and installation drawings.

D.4.2 Mounting Instructions

After evaluation of the mounting location has been completed and ensuring that requirements are met, install the unit assemblies.

Mount the GMU 11 in its mounting location, taking care to tighten the mounting screws firmly. Use of non-magnetic tools (e.g. beryllium copper or titanium) is recommended when installing or servicing the GMU 11. Do **not** use a screwdriver that contains a magnet when installing or servicing the GMU 11.

Refer to [Section D.6](#) for outline and installation drawings.

D.5 J441 Connector

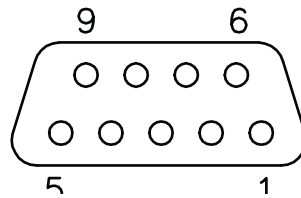

Figure D-2 J111 on GMU 11, as viewed looking at connector on unit

Pin	Pin Name	I/O
1	CAN BUS HI	I/O
2	CAN BUS LO	I/O
3	RESERVED	--
4	RESERVED	--
5	RESERVED	--
6	RESERVED	--
7	AIRCRAFT POWER 1	IN
8	AIRCRAFT POWER 2	IN
9	POWER GROUND	--

D.5.1 Power Function



NOTE

The GMU 11 must be powered from aircraft power.

The GMU 11 is compatible with 14V and 28V systems. AIRCRAFT POWER 1 and AIRCRAFT POWER 2 are “diode ORed” to provide power redundancy.

Pin Name	Connector	Pin	I/O
AIRCRAFT POWER 1	J111	7	In
AIRCRAFT POWER 2	J111	8	In
POWER GROUND	J111	9	--

D.5.1.1 CAN Bus

The CAN Bus conforms to the BOSCH standard for Controller Area Network 2.0-B, and complies with ISO 11898. Refer to [Section 2.2.2](#) for details on wiring the CAN bus.

Pin Name	Connector	Pin	I/O
CAN BUS HI	J111	1	I/O
CAN BUS LO	J111	2	I/O

D.6 Outline and Installation Drawings

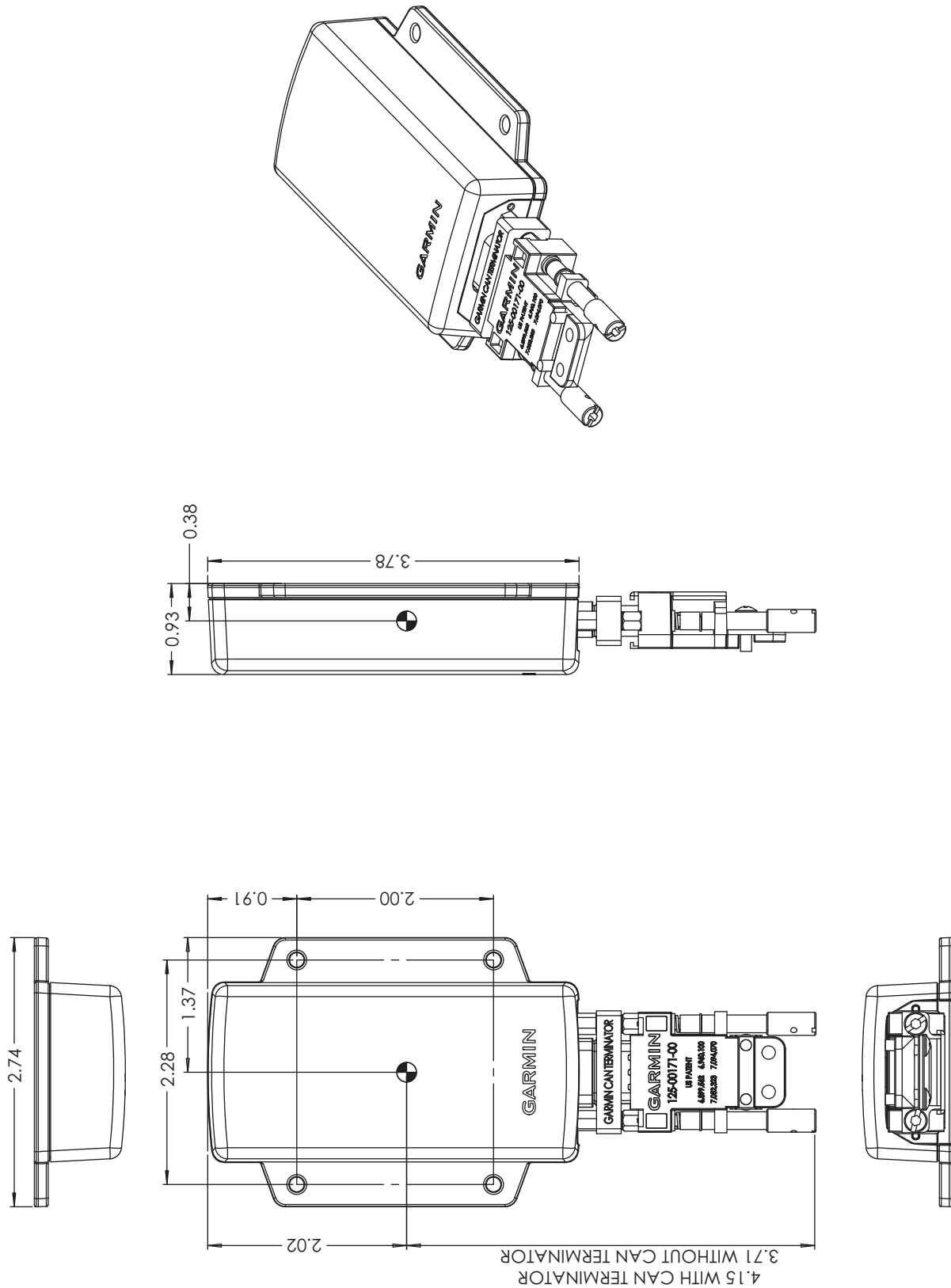

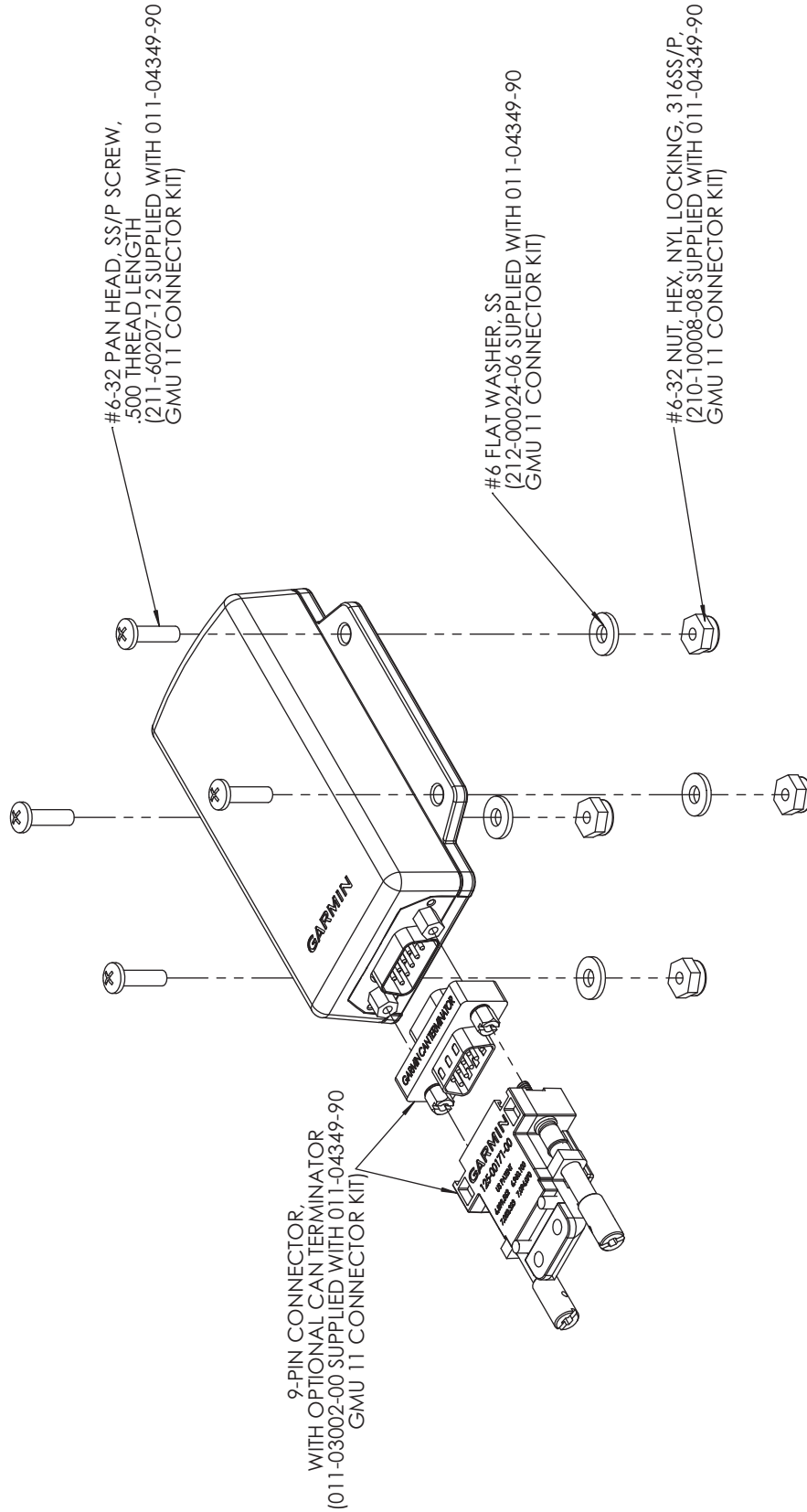
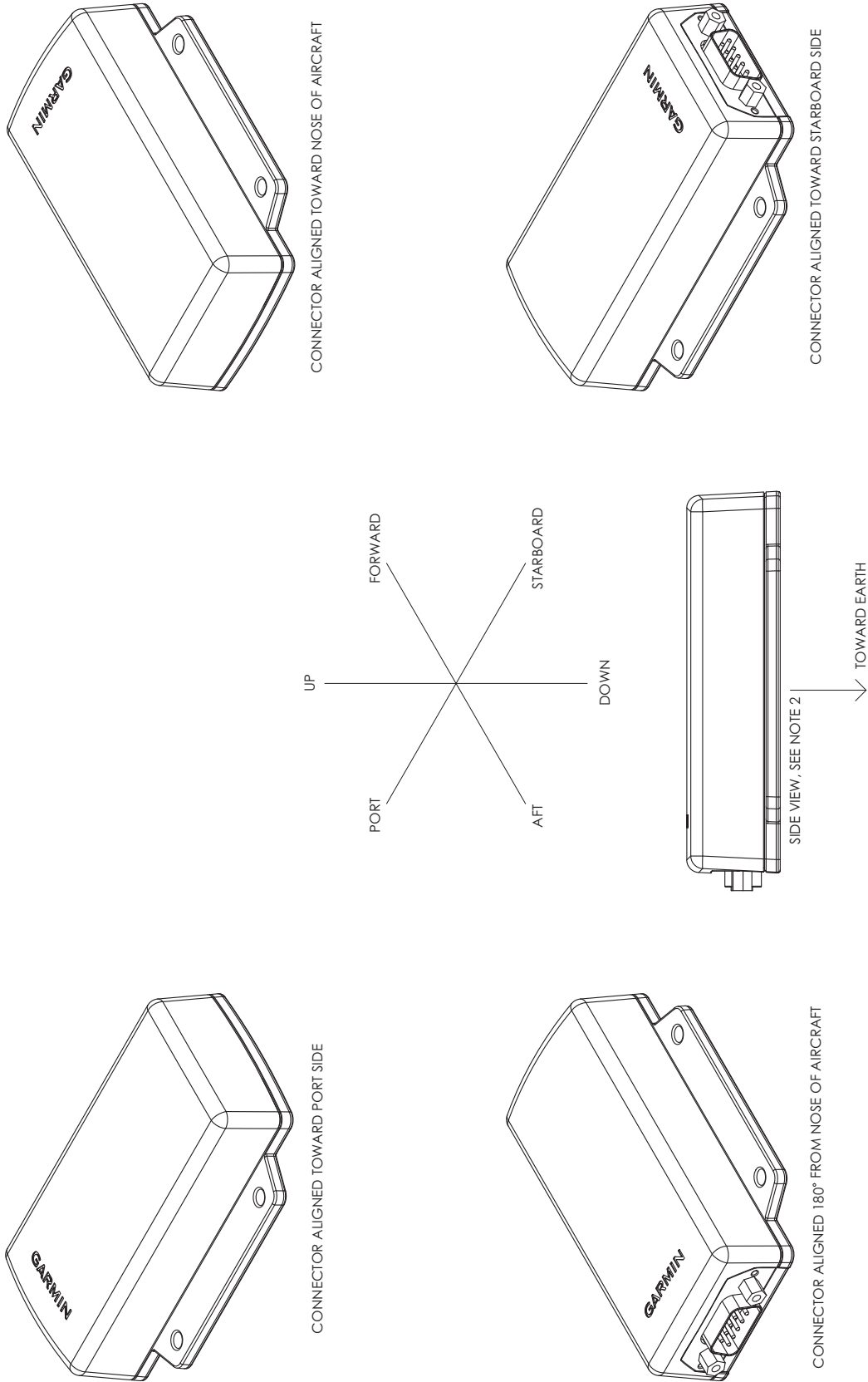

Figure D-4 GMU 11 Installation Drawing

GMU 11 INSTALLATION ORIENTATIONS



- NOTES:
1. ALIGN THE GMU 11 CONNECTOR TO WITHIN 0.5° TO ANY OF THE 4 AIRCRAFT AXIS SHOWN.
 2. THE GMU 11 MUST BE MOUNTED SUCH THAT THE BOTTOM OF THE UNIT IS FACING THE EARTH.

Figure D-5 GMU 11 Orientation Drawing

APPENDIX E GSA 28 (AUTOPILOT SERVO) INSTALLATION

This section contains general information as well as installation information for the GSA 28 Servo Actuator. Use this section to mount the GSA 28 unit.

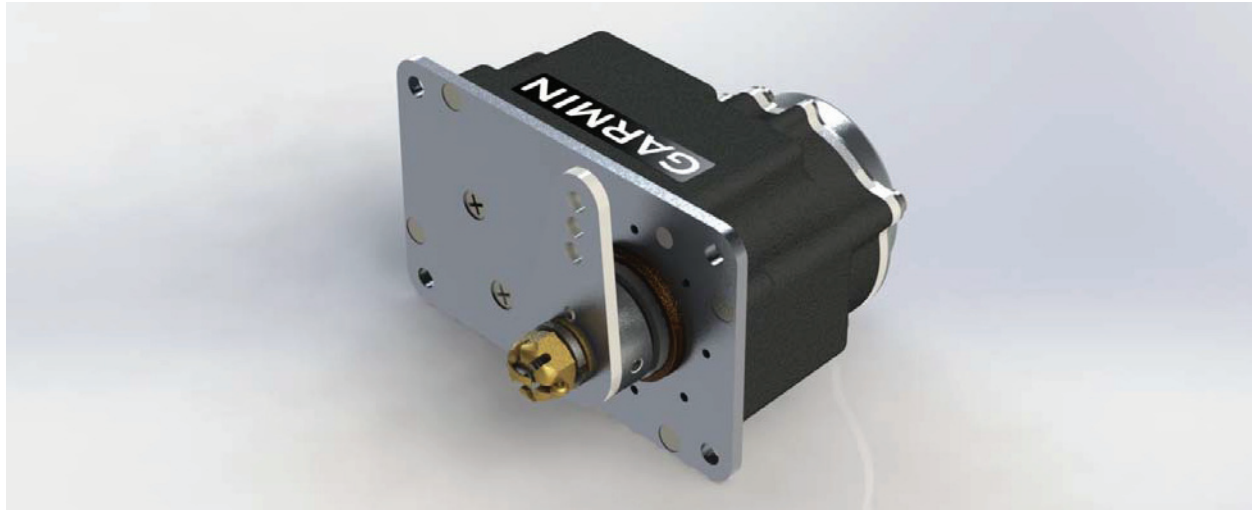

Figure E-1 GSA 28 Unit View

E.1 Equipment Description



NOTE

There is no TSO/ETSO applicable to the GSA 28.

The GSA 28 servo is an autopilot servo intended for use in non FAA certified aircraft, including light sport and home-built aircraft. The servo is intended to be used as part of the G5 system.

The function of the GSA 28 is to drive a flight-control axis (pitch, roll) of the aircraft. The servo can also be installed in the rudder control system to provide yaw damping. Trim drive support is available for any axis using various 3rd party (i.e. Ray Allen) trim motors. The GSA 28 can also be used as the trim actuator in the pitch and/or roll axis. All configurations can be used with or without auto-trim in each axis.

- Roll autopilot only
- Pitch/roll autopilot
- Pitch/roll autopilot with yaw damper

The GSA 28 servo features an advanced brushless DC motor and gearbox, with an engagement clutch to allow for very low-friction operation of the aircraft flight controls with clutch disengaged. The GSA 28 performs continuous internal monitoring and fault detection, and can also safely be back-driven by the pilot in the event of an engagement clutch fault condition. An advanced electronic slip clutch provides the ability for the pilot to overpower the servo at a configurable torque threshold without requiring use of a consumable shear pin or additional moving parts.



NOTE

The GSA 28 engagement clutch is actuated by an internal solenoid. An audible clicking sound when the servo is engaged or disengaged is normal and expected.

Under normal conditions, the GSA 28 servo operates based on flight director commands from the G5. When used with an optional GMC Mode Controller, the GSA 28 maintains a reversionary capability to engage and fly the aircraft in basic wings-level and altitude-hold modes even if all GDU displays in the

aircraft are unavailable.

GSA 28 autopilot servos can be used to control the trim system in an aircraft. When the autopilot is disengaged, the servos can adjust the trim speed based on the current aircraft airspeed. This allows the trim to run slower at high airspeeds and faster at low airspeeds. When the autopilot is engaged in the air, the servos can adjust the trim control to minimize the force on the primary controls. This helps ensure the aircraft will be properly trimmed when the autopilot is later disengaged. This feature works the same whether using a 3rd party trim motor or a GSA 28 as the trim actuator. When using a GSA 28 as the trim actuator, the following must be considered:

- The GSA 28 cannot hold a fixed position when disengaged, as the shaft will turn freely. It can only be used in installations where the trim actuator does not need to hold a fixed position when powered off. An acceptable application is the GSA 28 driving a manual pitch trim system via capstan and bridle cables.
- When used as the trim servo, the GSA 28 communicates via the CAN bus (same as the other servos communicate), no RS-232 or other data connection is required. The GSA 28 needs to be ID strapped appropriately for the pitch trim location (see [Section E.8.5](#)).
- The GSA 28 should be connected to the CWS/DISCONNECT input. For manual electric trim, trim inputs from the stick or relay should be wired directly to the GSA 28 being used as the trim actuator. Do not wire trim related input or outputs to the pitch servo.

During the flight test phase, the trim system is configured and set up after the primary autopilot performance has been properly configured. This is done so the pilot can focus on properly adjusting the performance of the primary autopilot system without having the auto-trim functionality interfere.



NOTE

Ensure basic autopilot functionality is properly adjusted before enabling trim control for any servo.

E.1.1 Status LED

The GSA 28 has an LED on its outer case that indicates its current status. See [Table 2-2](#) for details.

E.2 Equipment Available

Table E-1 GSA 28 Part Numbers

Model	Assembly Part Number	Unit Only Part Number
GSA 28 Servo Actuator, Unit Only	010-01068-00	011-02927-00

E.3 General Specifications

Table E-2 General Specifications

Characteristic	Specification
Height	4.0 inches (10.16 cm)
Width	2.5 inches (6.35 cm)
Depth	2.8* inches (7.11 cm)
Weight	1.40** lbs, (0.635 kg)

*Harness connector not included

**Accessories not included

E.3.1 Power Specifications

The GSA 28 trim outputs are capable of sourcing a maximum of 1A of current to drive a DC trim motor at 12V, or a maximum of 500 mA of current to drive a DC trim motor at 24V.

To use the GSA 28 to drive DC trim motors requiring higher current, a third-party interface may be used.



CAUTION

The DC trim motor connected to the GSA 28 should be rated for the full power supply voltage being used to power the GSA 28. If the GSA 28 is connected by a 24-28V power input, the trim motor must also be rated for 28V.



NOTE

The GSA 28 does not provide a voltage step-up service. To drive a 24V trim motor, the GSA 28 must be to be supplied with 24V or higher.

Table E-3 GSA 28 Power Specifications

Supply Voltage	Current Draw
14 Vdc without Auto-trim	0.36 Amp (typical), 1.80 Amp (max)
28 Vdc without Auto-trim	0.20 Amp (typical), 1.00 Amp (max)
14 Vdc with Auto-trim	0.36 Amp (typical), 2.80 Amp (max)

E.3.2 Torque Specifications

Table E-4 GSA 28 Torque Specifications

Characteristic	Specification
Maximum Rated Torque	60 in-lbs

E.4 Required Equipment

Table E-5 lists the kits available for the GSA 28.

Table E-5 GSA 28 Available Equipment w/Weights

Item	Garmin P/N	Weight
GSA 28 Connector Kit	011-02950-00	0.12 lb (0.054 kg)
GSA 28 Connector Kit, 90°	011-02950-01	0.13 lb (0.059 kg)
GSA 28 Stop Bracket Kit	011-02951-00	0.03 lb (0.014 kg)
GSA 28 Mounting Kit, Generic, Push-Pull	011-02952-00	0.26 lb (0.118 kg)
GSA 28 Mounting Kit, Generic, W/Bracket	011-02952-01	0.50 lb (0.227 kg)
GSA 28 Mounting Kit, Generic, Capstan	011-02952-02	0.14 lb (0.064 kg)
GSA 28 Mounting Kit, RV-6 Roll	011-02952-10	0.55 lb (0.250 kg)
GSA 28 Mounting Kit, RV-4/8 Pitch	011-02952-11	0.51 lb (0.231 kg)
GSA 28 Mounting Kit, RV-7/8/10 Roll	011-02952-12	0.42 lb (0.191 kg)
GSA 28 Mounting Kit, RV-9 Roll	011-02952-13	0.42 lb (0.191 kg)
GSA 28 Mounting Kit, RV-6/7/9 Pitch	011-02952-14	0.37 lb (0.168 kg)
GSA 28 Mounting Kit, RV-10 Pitch	011-02952-15	0.48 lb (0.218 kg)
GSA 28 Mounting Kit, RV-10 Yaw	011-02952-16	0.60 lb (0.272 kg)
GSA 28 Removal Adapter	011-03158-00	0.03 lb (0.014 kg)

Table E-6 Contents of Connector Kit (011-02950-00)

Item	Garmin P/N	Quantity
Sub-Assy, Bkshl w/Hdw, Jackscrew, 15/26 Pin	011-01855-01	1
GSA 28 Removal Adapter	011-03158-00	1
Connector, Rcpt, D-SUB, Crimp Socket, Commercial, 15 Ckt	330-00625-15	1
Cont, Sckt, Mil Crp, Size 20, 20-24 AWG, RoHS	336-00022-02	16

Table E-7 Contents of Connector Kit, 90° (011-02950-01)

Item	Garmin P/N	Quantity
Sub-Assy, Bkshl w/Hdw, Jackscrew, 90°, 15/26 Pin	011-01959-01	1
GSA 28 Removal Adapter	011-03158-00	1
Connector, Rcpt, D-SUB, Crimp Socket, Commercial, 15 Ckt	330-00625-15	1
Cont, Sckt, Mil Crp, Size 20, 20-24 AWG, RoHS	336-00022-02	16

E.4.1 Additional Equipment Required

- Cables: The installer will fabricate and supply all system cables.
- Mounting hardware is included in the available mounting kits.

E.5 Unit Installation

Fabrication of a wiring harness is required. Sound mechanical and electrical methods and practices should be used for installation of the GSA 28. Refer to [Section 2.2](#) for wiring considerations, and to [Section E.8](#) for pinouts.

Connector kits include backshell assemblies. Garmin's backshell connectors give the installer the ability to quickly and easily terminate shield grounds at the backshell housing. The instructions needed to install the Jackscrew Backshell are located in [Section 6](#).

E.5.1 Pinouts

See [Section E.8](#) for pinout information.

E.5.2 Mounting Requirements



WARNING

It is vital to ensure the autopilot servo and aircraft control linkage is free to move throughout its entire range of travel without binding or interference. Failure to ensure adequate clearance between the moving parts of the control system linkage and nearby structure could result in serious injury or death. If any control system binding or interference is detected during installation or preflight inspection, it must be corrected before flight.



CAUTION

Do not mount the GSA 28 on the 'hot' side (engine side) of the firewall, or in any location where it would be exposed to radiated heat from the engine.

E.5.2.1 Optional attachments

The GSA 28 is supplied from the factory with a standard crank arm attachment ([Figure E-2](#), [Figure E-8.1](#), [Figure E-8.2](#), and [Figure E-8.3](#)). Also available are a long crank arm supplied in the 011-02952-10 RV-6 roll kit and a capstan attachment available in the 011-02952-02 Capstan Kit. If one of these optional attachments will be used, it is up to the installer to remove the standard crank arm and replace it with the optional attachment. When removing the standard arm, keep the castle nut, lock washer, and flat washer as these items will need to be re-used with the optional attachment. Discard cotter pin that was removed from the GSA 28 and replace with pin provided with optional attachment. Refer to [Figure E-8.3](#) and [Figure E-8.4](#) for more details and instructions for tightening the castle nut.



WARNING

Cotter pins supplied with GSA 28 are only intended for one time use. If removed from GSA 28 discard and use new cotter pin.

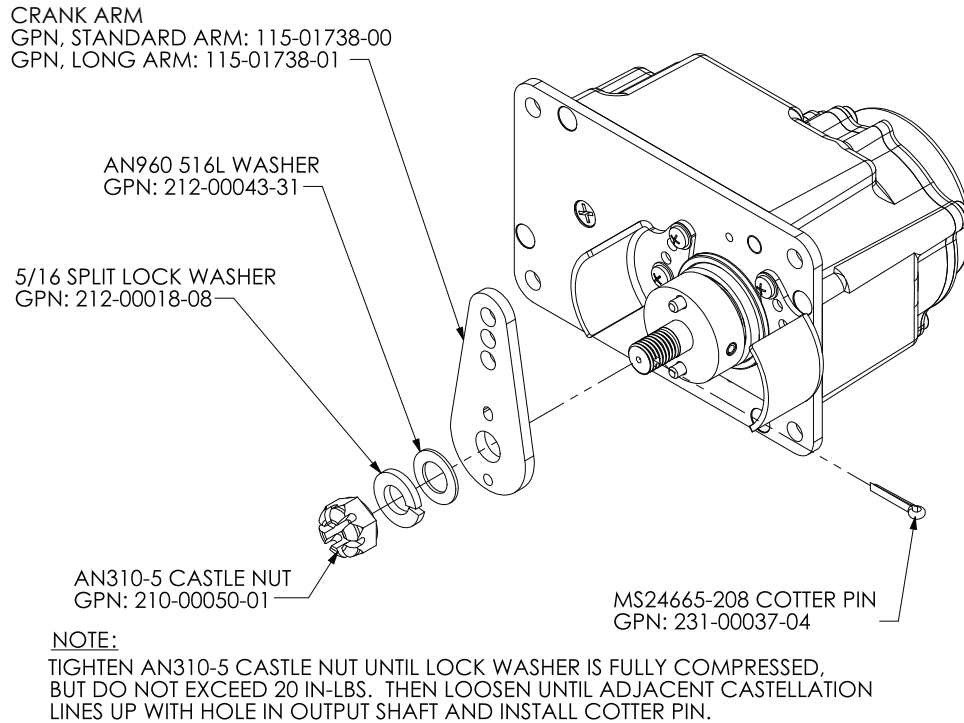

Figure E-2 Crank Arm Assembly

E.5.2.2 Stop Bracket Kit

Every GSA 28 is supplied with a 011-02951-00 stop bracket kit. The intention of this stop bracket is to create redundant stops for the servo control arm that prevents the servo's arm from going over-center relative to the push rod connected to the servo's arm. It is highly recommended this part gets installed with every push-pull application. The stops created by installing this bracket are redundant in the sense that the aircraft's built-in stops should always be used as the primary means of limiting travel of the servo's control arm. This stop bracket limits the motion of the standard control arm to 100° total travel. This bracket should be positioned such that the stop bracket flanges are as close as practical to being equal distance from the servo's control arm while at the center of travel. Also, to prevent an over-center condition, the servo's push rod should be as close as practical to perpendicular with the servo's control arm while positioned at the center of travel. The position of this bracket can be adjusted in increments of 15°. If necessary, further adjustments can be made by changing the length of the push rod connected to the servo. See [Figure E-8.2](#), and [Figure E-8.3](#) for more details.

After installation of the servo is complete, verify that the stop bracket does NOT impede the full movement of the associated control.



WARNING

An over-center position of the servo control arm relative to the attached push rod can cause the flight controls to jam. This could result in serious injury or death. Please be sure this is well understood prior to flying with the GSA 28 servo.

The 011-02951-00 stop bracket kit is supplied with four #4-40 screws used to attach the bracket to the front face of the servo. The screws provided are 0.25” long. This length of screw is appropriate if there is no bracket or spacers in-between the stop bracket and servo. If a mounting bracket or spacers of thickness .040” or greater will be placed in-between the stop bracket and servo, longer screws should be used to mount the stop bracket. It is recommended the thread engagement into the GSA 28, as measured from the front face of the servo shall be 0.112” – 0.25”. If screws other than what is provided will be used, be sure to use thread locking compound or a proper thread locking patch combined with the lock washers provided. Also be sure to follow the recommended tightening torque specified in [Figure E-8.2](#).



CAUTION

If screws are being used to mount the stop bracket to the front face of the GSA 28 are different than the screws provided with the stop bracket kit, care must be taken to ensure these screws are not long enough to contact moving parts inside the GSA 28. Maximum screw insertion, as measured from the front of the GSA 28, must be less than 0.25” to avoid contact with parts inside the GSA 28.



CAUTION

To avoid the possibility of contaminating the internal rotating mechanisms of the GSA 28, do not apply thread locking compound directly to the stop bracket attachment holes in the front face of the servo. Instead, apply a small amount of thread locking compound to the threads of the stop bracket screws before the screws are inserted. Thread locking compound is not required upon initial installation of the included stop bracket screws, which are supplied with thread locking compound already applied.

E.5.2.3 Trim Motor Interface to a 3rd Party Motor

The GSA 28 provides an optional interface between the pilot's electric trim switch and a 14 Vdc trim motor. This interface shall be used only when interfacing to a 3rd party trim motor. This interface is not to be used when a GSA 28 is being used as the trim actuator. When the GSA 28 servo is engaged (i.e. autopilot on) in the air, it automatically drives the connected trim motor as required to relieve control forces for the associated pitch, roll, or yaw axis. When the GSA 28 servo is not engaged (i.e. autopilot off), it provides manual electric trim (MET) functionality by running the trim motor in response to pilot input. The GSA 28 can be configured to automatically reduce the speed of the trim motor at higher airspeeds, in order to provide finer control of trim tab position. In the event that power to the GSA 28 is removed, a fail-safe system connects the trim input switch directly to the trim motor. In this condition, the trim switch powers the trim motor directly and the motor runs at its full speed when the switch is pressed. The same condition also occurs if a trim switch and motor are connected to the GSA 28, but the trim control function is disabled.



CAUTION

The GSA 28 trim outputs can source a maximum of 1A of current to drive a DC trim motor at 12V, or a maximum of 0.5A of current to drive a DC trim motor at 24V. Do not connect a trim motor that requires higher current as this will damage the GSA 28.



NOTE

The GSA 28 supports a single trim switch input only. For use with multiple trim switches (e.g. pilot and co-pilot), a third-party relay deck or other device capable of mixing multiple trim switches into one is required.

E.5.2.4 CWS/DISCONNECT

The CWS/DISCONNECT button is used to disengage the autopilot system. It can also optionally be used for autopilot engagement and control wheel steering (see [Section 8.4.7.9](#)). The CWS/DISCONNECT input to all servos should be tied together and connected to a normally open momentary push button that connects to ground when pressed (see [Figure 7-8](#) and [Figure 7-9](#)).



NOTE

The CWS/DISCONNECT button must be mounted where it is easily accessible to the pilot during all phases of flight. The pilot must have ability to quickly disconnect the autopilot under all circumstances.

E.5.2.5 GSA 28 Removal Adapter

The GSA 28 connector kit is shipped with a GSA 28 removal adapter (011-03158-00). This part is not intended to be installed with the GSA 28, but is used to replace the GSA 28 when the harness connector is un-plugged. The removal adapter contains an internal 120 Ω resistor between pins 2 and 3 for CAN termination. It also contains shorts between pins 11 & 13 and 12 & 14 to pass through power for trim motors. The intention of this component is to allow operation of the CAN bus and trim motors when the servos are not plugged into the harness. It is recommended that a removal adapter is kept with each servo installation, in case the GSA 28 needs to be removed without losing functionality of the CAN bus and trim motors.

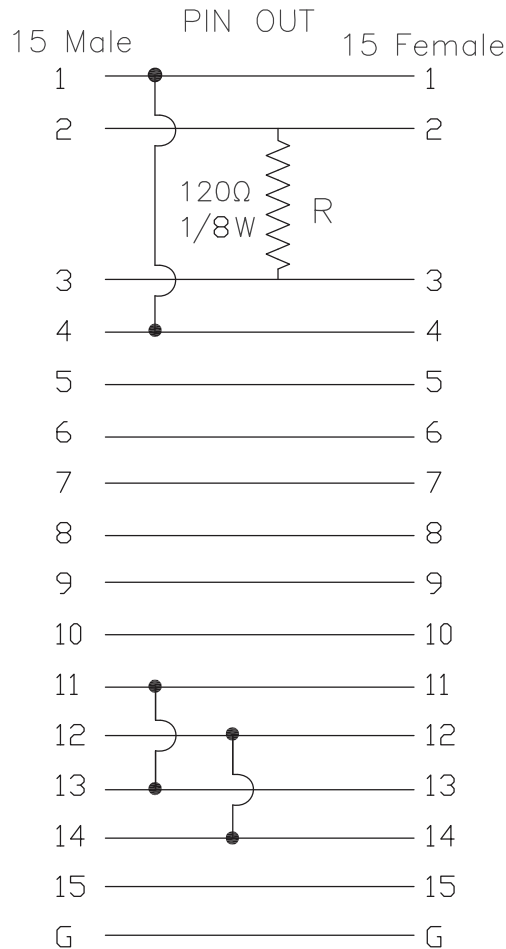

Figure E-3 Wiring Diagram For GSA 28 Removal Adapter

E.5.2.6 GSA 28 Mounting Kits

Garmin currently provides the mounting kits listed in Table E-8 for the GSA 28 Servo:

Table E-8 Mounting Kits

Garmin P/N	Description	Mounting Bracket Included	Install Manual Figures
011-02952-00	Sub-Assy, GSA 28 Mounting Kit, Generic, Push-Pull	No	E-8.7
011-02952-01	Sub-Assy, GSA 28 Mounting Kit, Generic, W/Bracket	Yes	E-8.8
011-02952-02	Sub-Assy, GSA 28 Mounting Kit, Generic, Capstan	No	E-8.4
011-02952-10	Sub-Assy, GSA 28 Mounting Kit, RV-6 Roll	Yes	E-9.1 , E-9.1 , E-9.1
011-02952-11	Sub-Assy, GSA 28 Mounting Kit, RV-4/8 Pitch	Yes	E-10.1 , E-10.1 , E-10.1 , E-10.1
011-02952-12	Sub-Assy, GSA 28 Mounting Kit, RV-7/8/10 Roll	Yes	E-11.1 , E-11.1
011-02952-13	Sub-Assy, GSA 28 Mounting Kit, RV-9 Roll	Yes	E-12.1 , E-12.1
011-02952-14	Sub-Assy, GSA 28 Mounting Kit, RV-6/7/9 Pitch	Yes	E-13.1 , E-13.1
011-02952-15	Sub-Assy, GSA 28 Mounting Kit, RV-10 Pitch	Yes	E-14.1 , E-14.1
011-02952-16	Sub-Assy, GSA 28 Mounting Kit, RV-10 Yaw	Yes	E-15.1 , E-15.1 E-15.1

The “generic” kits listed in Table E-8 (011-02952-00, -01, & -02) are not specific to any airframe. The airframe specific kits (GPN 011-02952-10 through -16) are for use with the specified experimental aircraft. The contents of each kit as well as specific instructions for their use are detailed in the figures listed in Table E-8.

E.5.2.7 Generic Push/Pull Kits

The 011-02952-00 and -01 kits are generic kits for push/pull applications. This kit is supplied with a 3/8" diameter x 8" long solid rod (Figure E-4). This rod is intended to be used as the attachment link between the GSA 28 and the flight control system. It is the installer's responsibility to cut this rod to the correct length and tap the ends for the male rod end bearings. It is recommended these push rods are tapped to a depth of at least 0.61" to accommodate the entire thread of the rod end bearing (minus the jam nut). The length of the push rod is adjustable by changing the thread engagement between the male rod end bearings and push rod. The acceptable range of thread engagement is 0.492" +/-0.117". It is highly recommended the AN315-3R jam nuts are used and properly tightened. A push rod without a tightened jam nut will create backlash that can diminish autopilot performance.



WARNING

Thread engagement between the male rod end bearings supplied with GSA 28 mounting kits and push rod must not be less than 0.375". This minimum engagement length is recommended to prevent push rod from coming apart.

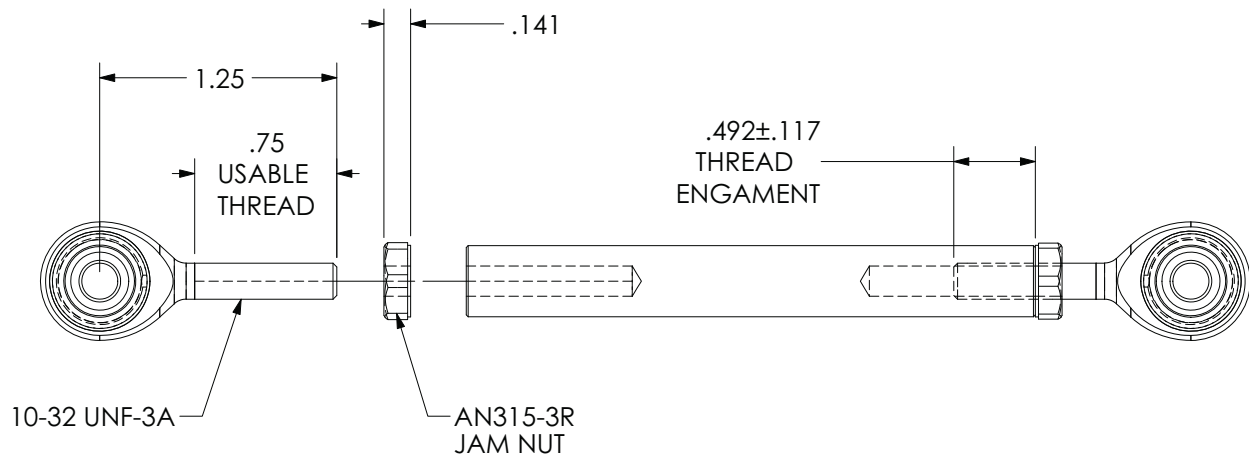

Figure E-4 General Dimensions For Servo Push Rod And Rod End Bearings

E.5.2.8 Capstan Kit

The capstan kit is part number 011-02952-02. This kit contains a capstan, a cable guard, and fasteners used to attach these items.

The capstan is designed to accept a MS20663C2 double shank ball with a 1/16" diameter cable. This kit does not currently include a bridle cable or cable clamps necessary to link the capstan to the flight control cables as these items are generally specific to each aircraft type. The required bridle cable (Figure E-5) is a 1/16" cable with a MS20663C2 ball and double shank fitting swaged onto the cable where it engages with the capstan drive wheel. The MS20664C2 ball and shank fittings on the ends keep the cable from fraying.

Several companies sell custom made cable assemblies suitable for this application, a few of these are:

McFarlane Aviation

Phone: 866-920-2741

www.mcfarlane-aviation.com

Aircraft Spruce

Customer Service: 1-800-861-3192

www.aircraftspruce.com/catalog/appages/cableassy.php



NOTE

When determining the length of the bridle cable to be ordered, be sure to allow for enough cable to make the required number of wraps around the capstan (see [Figure E-6](#)).

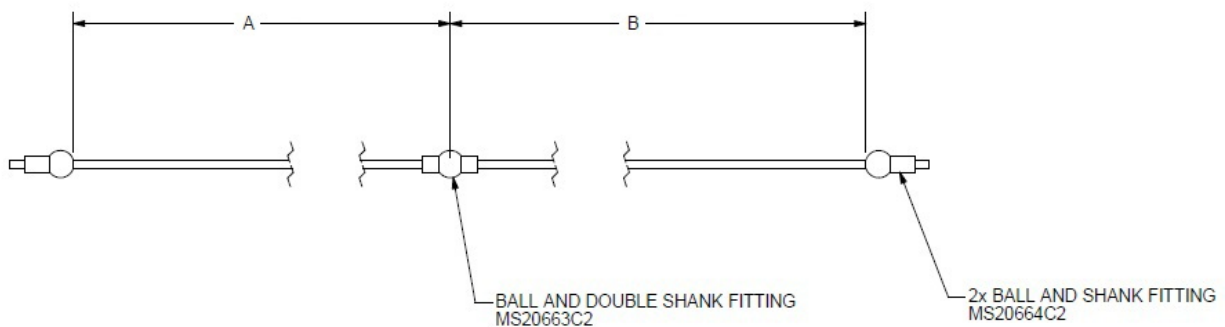

Figure E-5 Bridle Cable

Garmin recommends using the cable arrangement (ball centered in capstan) shown in Figure E-6 to avoid side-loading the servo center shaft.

CABLE EXITING IN OPPOSITE DIRECTION
 ONE FULL WRAP OF CABLE IS REQUIRED. BALL SHOULD BE IN CENTER OF CABLE WRAP WHEN CABLE IS AT CENTER OF TRAVEL. THE CAPSTAN MAY ROTATE A MAXIMUM OF 150° IN EITHER DIRECTION, ALLOWING A MAXIMUM OF 2.6" OF TRAVEL IN EACH DIRECTION.

BOTH CABLES EXITING CAPSTAN IN SAME DIRECTION
 1.5 FULL WRAPS OF CABLE IS REQUIRED. BALL SHOULD BE IN CENTER OF CABLE TRAVEL. CAPSTAN MAY ROTATE A MAXIMUM OF 150° EITHER DIRECTION FROM CENTER POSITION, ALLOWING A MAXIMUM OF 2.6" OF TRAVEL EACH DIRECTION.

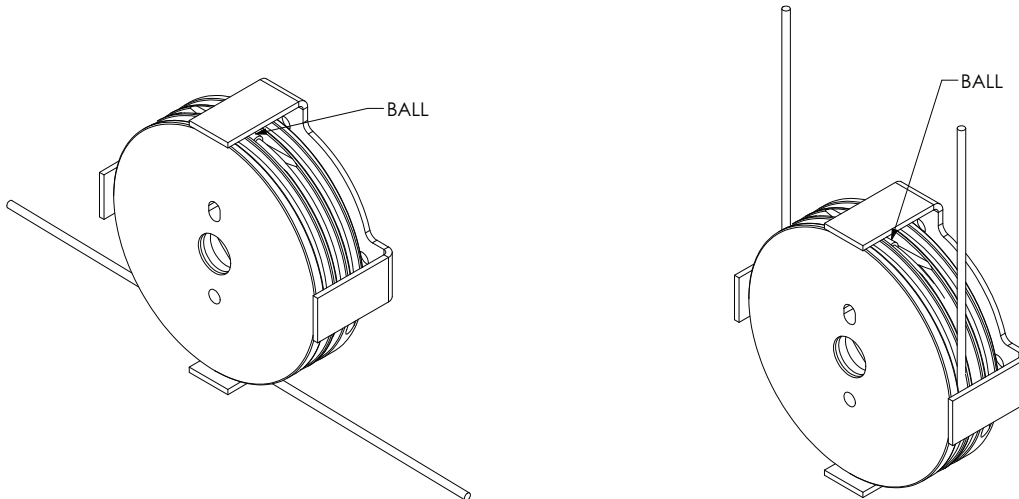

Figure E-6 Cable in Capstan



WARNING

The ball must be located in the center of travel on the capstan when the flight control is in the neutral position. When the flight control is moved to the limits of its travel, the ball must not have any possibility of exiting the capstan groove.

The bridle cable must wrap around the capstan either 1 or 1.5 full turns, as shown in Figure E-6, and must be routed in a way that avoids the possibility of binding.

If the installation would require more than +/- 150° of capstan rotation or more than +/- 2.6 inches of cable travel, the GSA 28 servo and capstan cannot be used.

Failure to closely follow the capstan installation guidance in this section could cause the aircraft flight controls to jam, resulting in serious injury or death

The 011-02952-02 capstan kit is provided with four #4-40 screws and lock washers for attaching the cable guard. The screws provided are 0.25" long. This length of screw is appropriate if there is no bracket or spacers in-between the cable guard and servo. If a mounting bracket or spacers of thickness .056" or greater will be placed in-between the stop bracket and servo, longer screws should be used to attach the cable guard. It is recommended the thread engagement into the GSA 28, as measured from the front face of the servo shall be 0.112" – 0.25". If screws other than what is provided will be used, be sure to use thread locking compound or a proper thread locking patch combined with the lock washers provided. Also be sure to follow the recommended tightening torque specified in [Figure E-8.4](#).



CAUTION

If screws are being used to mount the cable guard to the front face of the GSA 28 are different than the screws provided with the stop bracket kit, care must be taken to ensure these screws are not long enough to contact moving parts inside the GSA 28. Maximum screw insertion, as measured from the front of the GSA 28, must be less than 0.25" to avoid contact with parts inside the GSA 28.

E.5.2.9 Aircraft Specific Mounting Kits

GSA 28 mounting kits are available for several experimental airframes. These mounting kits are listed in [Table E-8](#). All of these kits contain sheet metal mounting brackets that have been designed for the specific application and some contain push rods that have been designed for the specific application. The push rods are supplied cut to the appropriate length and tapped for the male rod end bearings provided. Overall push rod length as well as rod end bearing thread engagement length is provided on the drawings for each kit. The lengths specified are considered nominal. This length should be adjusted to fit the specific application. Ideal push rod length results in the push rod being perpendicular to the servo arm when it is at the center of travel.

It is recommended the stop bracket is installed with all push/pull applications. The drawings for each of these mounting kits shows the recommended orientation of this bracket. It is acceptable to deviate from these drawings if a better orientation has been determined by the installer. The best orientation results in the stop bracket flanges being equal distance from the servo arm when at the center of travel. See [Section E.5.2.2](#) on stop bracket kit for more details on mounting the stop bracket.

E.5.2.10 GSA 28 Installation Into a Non-Garmin Bracket

For installers who intend to fabricate their own brackets or use an existing bracket designed for a non-Garmin servo, consider the following:

The geometry of the GSA 28 varies from other popular servo models.

While the GSA 28 has the same 2.5" x 4.0" footprint, the same mounting hole locations, and uses the same mounting bolts as several other popular brands of autopilot servo, it does not fit into all mounting brackets designed for other servos. Some of the key differences to consider are:

- The GSA 28 servo has a larger bushing protrusion on the front plane of the servo.
- The harness connector is larger and in a different location relative to the output shaft.
- The GSA 28 does not contain tapped holes for mounting, instead it uses through holes and a thinner mounting flange.

Brackets fabricated for other manufacturer's servos may or may not have enough clearance for the large bushing protrusion. Modification to the bracket may be necessary to avoid interference with bushing protrusion. See [Figure E-7](#) for details.



CAUTION

Damage may occur to the GSA 28 if the mounting bracket overlaps the bushing protrusion when tightening down the mounting bolts. The damage can occur when the bushing is displaced into the unit. To prevent damage, ensure there is clearance for the bushing protrusion and be sure the GSA 28 mounting plate is flush with the bracket when the mounting bolts are being tightened.

For RV-7/8/9/10 roll installations, the rear support bracket used with other popular servos is not compatible with the GSA 28. This is because of the difference in thickness of the GSA 28 mounting flange relative the other servos.

Refer to [Figure E-8.1](#) for GSA 28 outline dimensions. See [Figure E-8.5](#) for recommended bracket cutout dimensions.



NOTE

Garmin cannot validate the structural integrity of non-Garmin brackets.

Mounting brackets provided in the Garmin GSA 28 mounting kits have been designed to withstand (and have been tested to) repetitive stress cycles endured during loads generated by the GSA 28 and aircraft vibrations. If using a non-Garmin mounting bracket, it is the installer's responsibility to ensure the bracket is structurally adequate for the application. It is important to consider the detrimental effects of bracket displacement and potential for fatigue failures due to reaction forces created by the GSA 28 loading and aircraft vibration.



WARNING

If using a non-Garmin mounting bracket, it is the installer's responsibility to ensure the bracket is structurally adequate for the application.

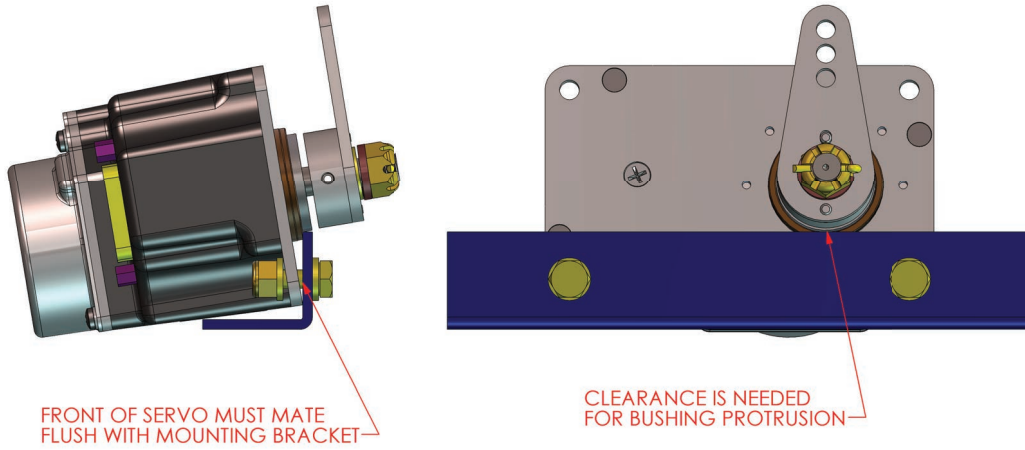

CORRECT

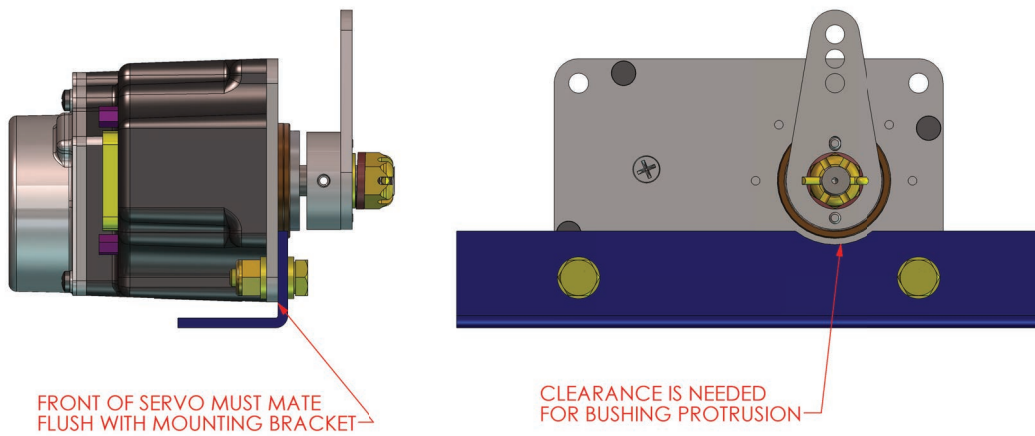

Figure E-7 Non-Garmin GSA 28 Bracket

E.5.3 Unit Mounting

For final installation and assembly, refer to the outline and installation drawings [Figure E-8.1](#) through [Figure E-14.1](#).



WARNING

Unless otherwise specified, tighten all threaded fasteners in accordance with FAA advisory circular AC 43-13-1B section 7.40, including adjustment for friction drag torque.

E.6 Unit Wiring

Refer to the [Section 7](#) interconnect drawings for connecting GSA 28 wiring.

E.7 Outline and Installation Drawings

Refer to the following figures for GSA 28 installation guidance.

GSA 28 STANDARD
011-02927-00

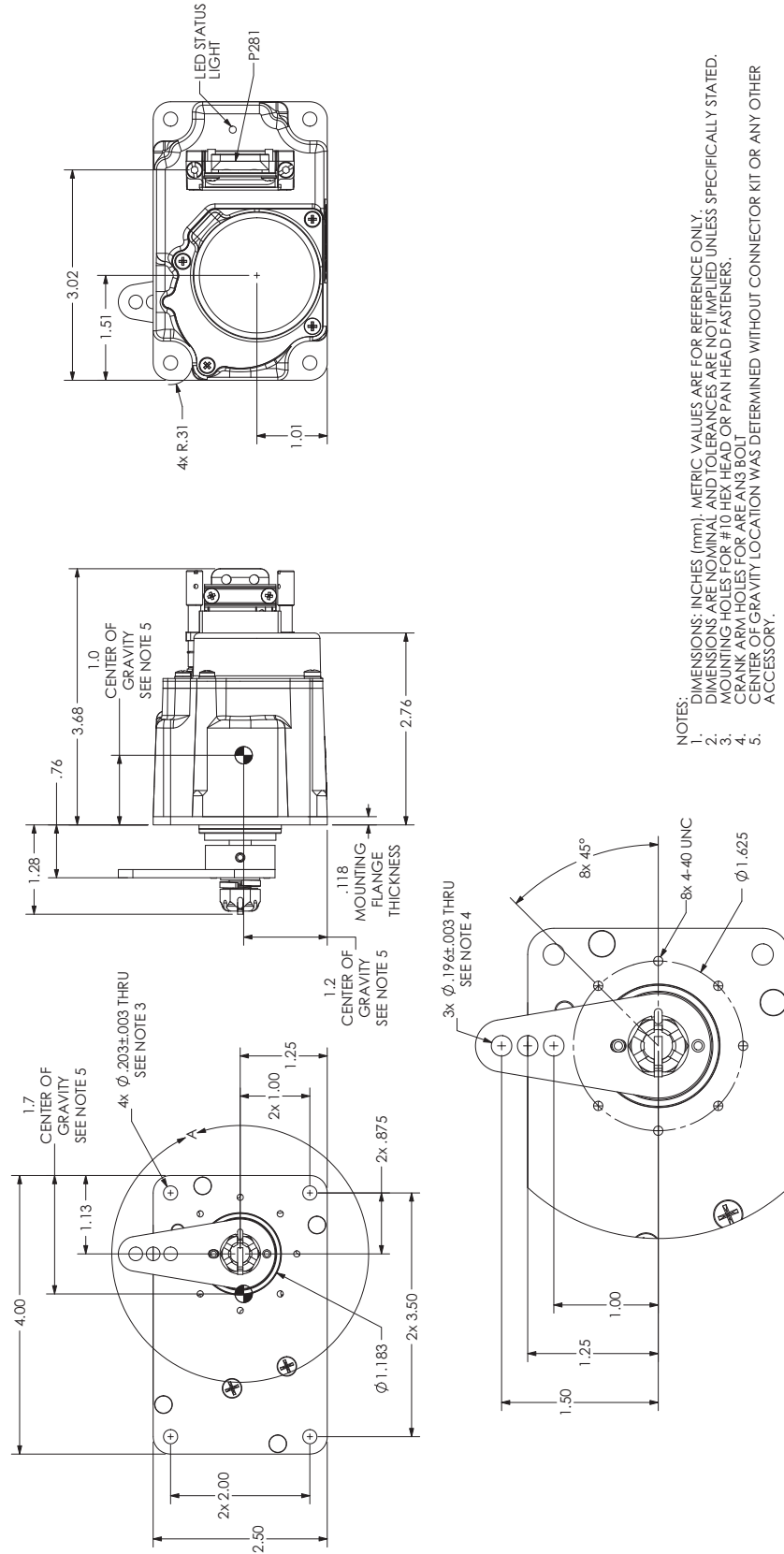

Figure E-8.1 GSA 28 Outline/Installation Drawing 011-02927-00

GSA28 STANDARD ACCESSORIES

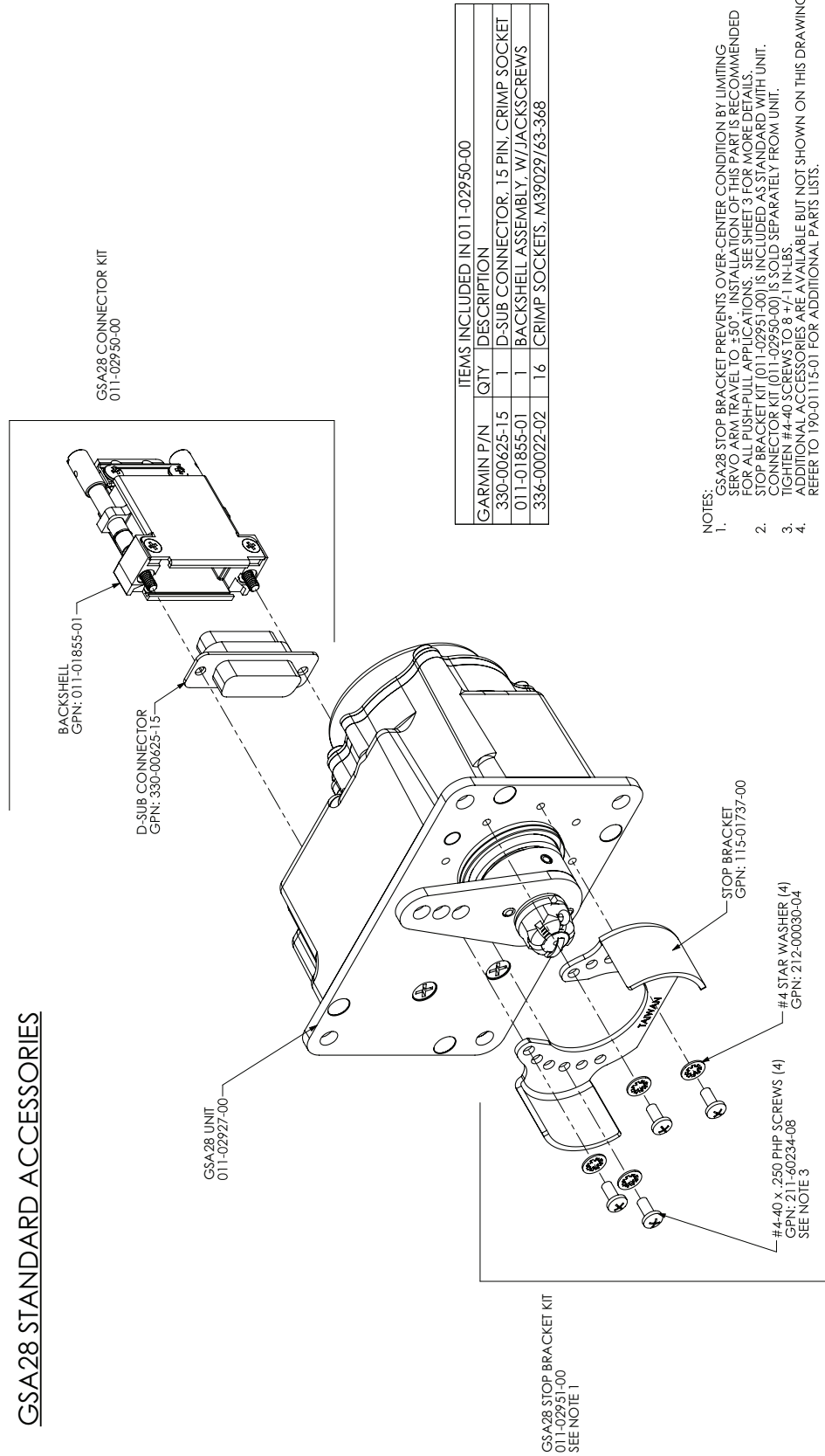
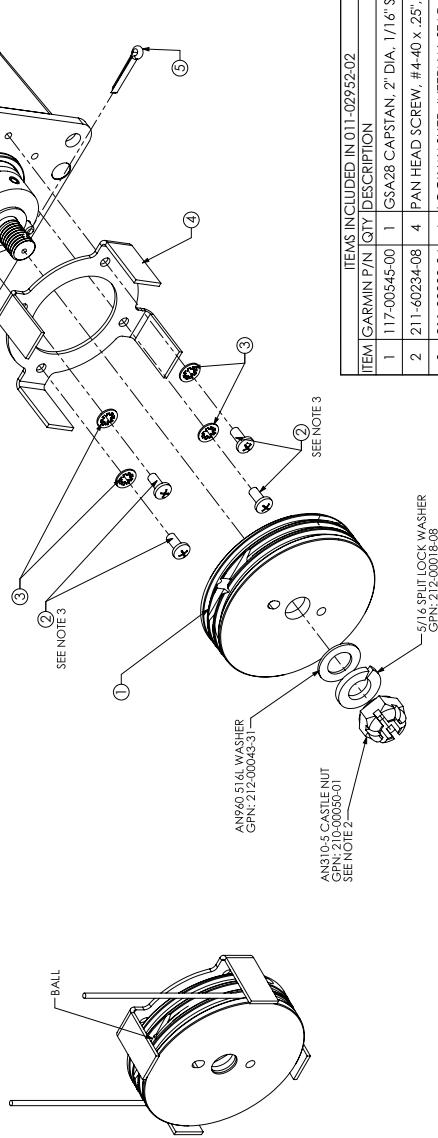

Figure E-8.2 GSA 28 Accessory Installation Drawing

GSA 28 WITH CAPSTAN KIT 011-02952-02

BOTH CABLES EXITING CAPSTAN IN SAME DIRECTION IS FULL WRAPS OF CABLE IS REQUIRED. BALL SHOULD BE IN CENTER OF CABLE WRAP. CAPSTAN SHOULD ROTATE A MAXIMUM OF 150° EITHER DIRECTION FROM CENTER POSITION, ALLOWING A MAXIMUM OF 2.6" OF TRAVEL EACH DIRECTION.

CABLE EXITING IN OPPOSITE DIRECTION ONE FULL WRAP OF CABLE IS REQUIRED. BALL SHOULD BE IN CENTER OF CABLE WRAP. WHEN CABLE IS AT CENTER OF TRAVEL, THE CAPSTAN SHOULD ROTATE A MAXIMUM OF 150° EITHER DIRECTION, ALLOWING A MAXIMUM OF 2.6" OF TRAVEL IN EACH DIRECTION.



ITEMS INCLUDED IN 011-02952-02			
ITEM#	GARMIN P/N	QTY	DESCRIPTION
1	117-00545-00	1	GSA28 CAPSTAN, 2" DIA., 1/16" SPIRAL
2	211-60234-08	4	PAN HEAD SCREW, #4-40 X .25", W/INT'L
3	211-00030-04	4	LOCK WASHER, INTERNAL STAR, #4
4	115-01737-10	1	GSA28 CABLE GUARD
5	231-00037-04	1	COTTER PIN, MS24665-208

CASTLE NUT, 5/16" LOCK WASHER, AND AN960 5/16L WASHER ARE NOT INCLUDED IN CAPSTAN KIT. THESE ITEMS ARE PROVIDED WITH GSA28 UNIT.

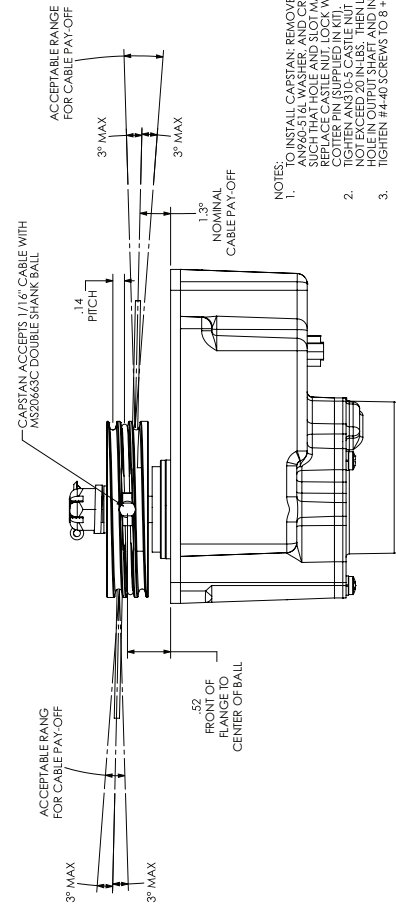

- NOTES:
- TO INSTALL CAPSTAN: REMOVE COTTER PIN, CASTLE NUT, 5/16" LOCK WASHER, AND AN960 5/16L WASHER. THEN REMOVE CABLE FROM CAPSTAN. REPLACE CASTLE NUT, LOCK WASHER, AND AN960 5/16L WASHER. INSTALL NEW COTTER PIN (SUPPLIED IN KIT) UNTIL LOCK WASHER IS FULLY COMPRESSED, BUT DO NOT EXCEED 20 IN-LBS. THEN LOOSEN UNTIL ADJACENT CASTELLATION LINES UP WITH HOLE IN OUTPUT SHAFT AND INSTALL COTTER PIN.
 - TIGHTEN #4-40 SCREWS TO 8 +/- 1 IN-LBS.
 -

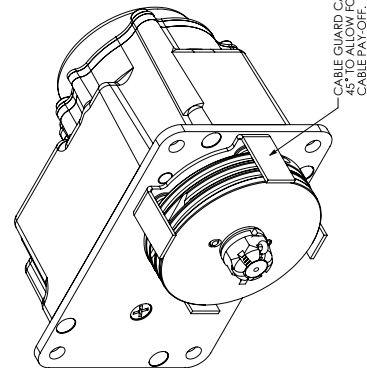
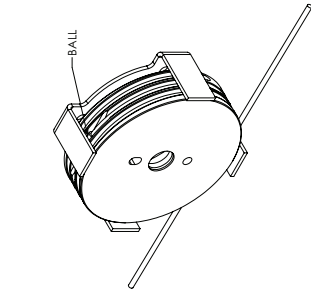
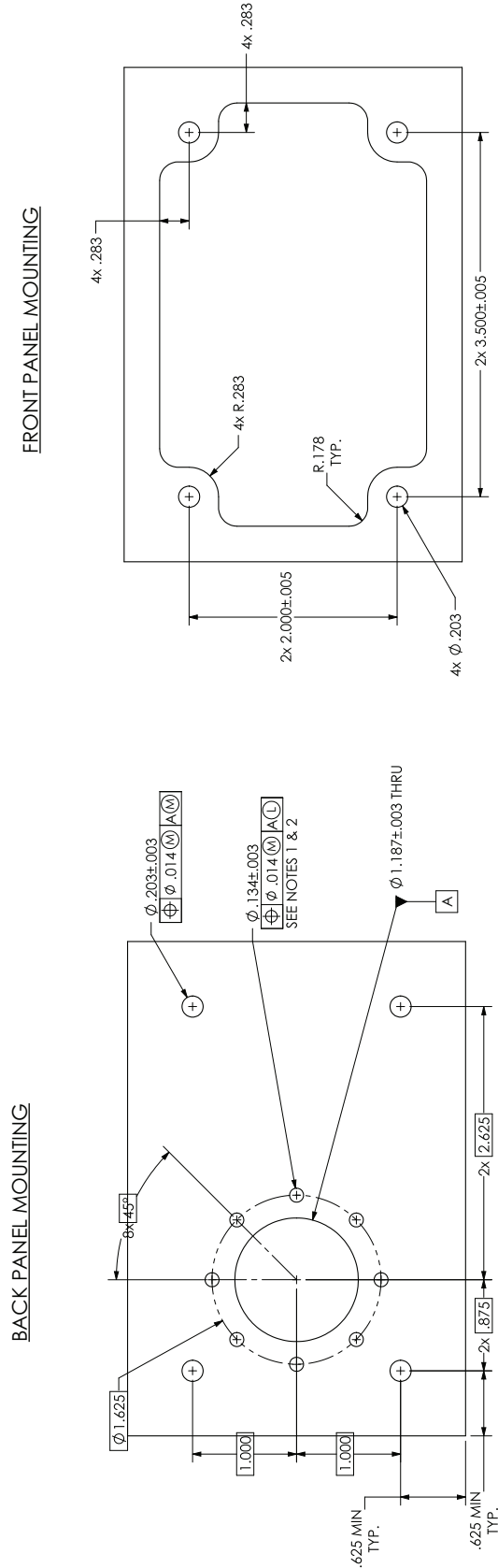

Figure E-8.4 GSA 28 with Capstan Kit and Cable Instructions (011-02952-02)

RECOMMENDED BRACKET CUTOUT DIMENSIONS



- NOTES:
1. CLEARANCE HOLES ARE FOR #4 SCREWS USED TO ATTACH STOP BRACKET OR CABLE GUARD.
 2. IT IS RECOMMENDED HOLES NOT BE CREATED UNLESS THEY WILL BE POPULATED WITH FASTENER.

Figure E-8.5 GSA 28 Recommended Bracket Cutout Dimensions

RECOMMENDED GSA 28 MOUNTING HARDWARE

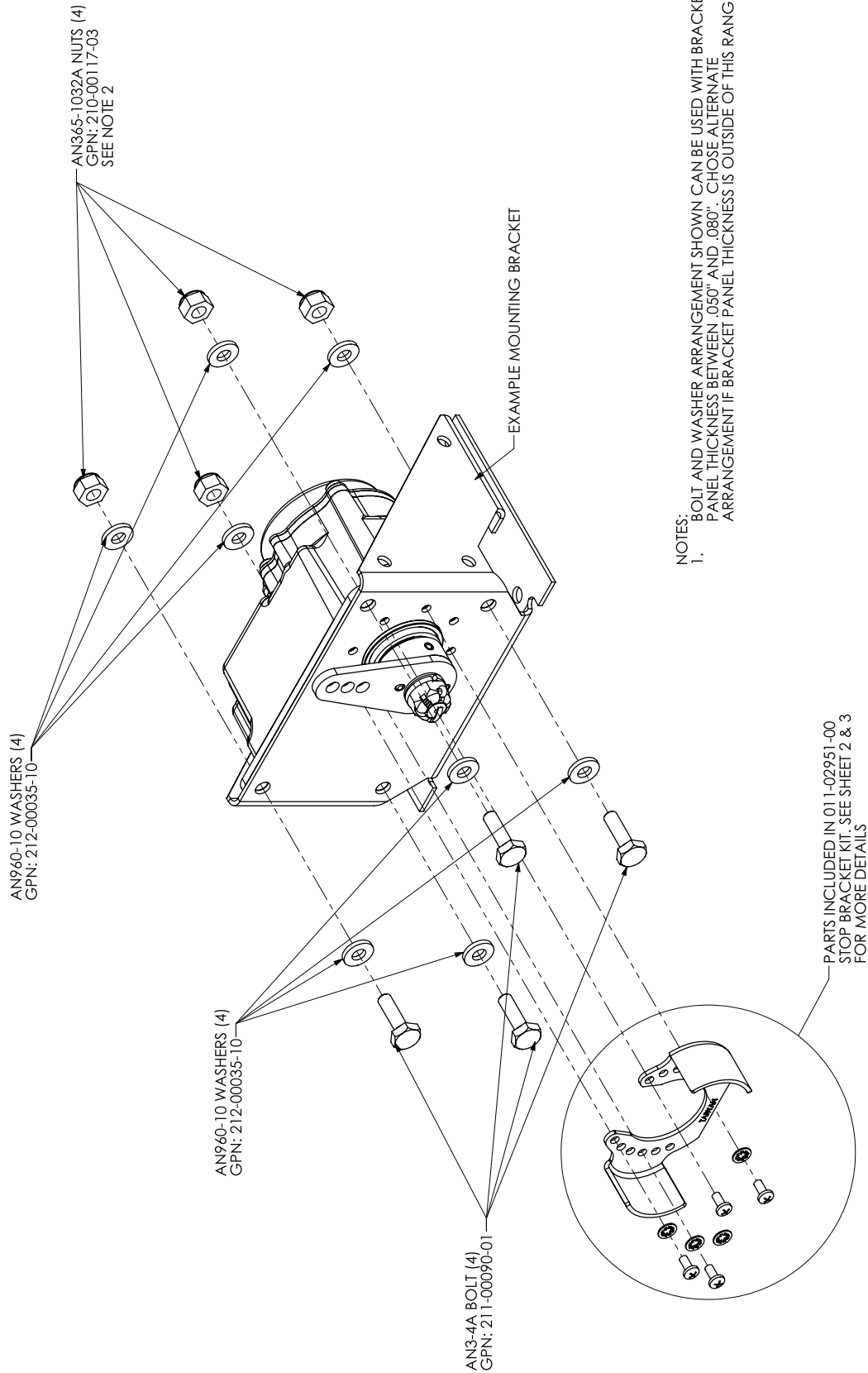
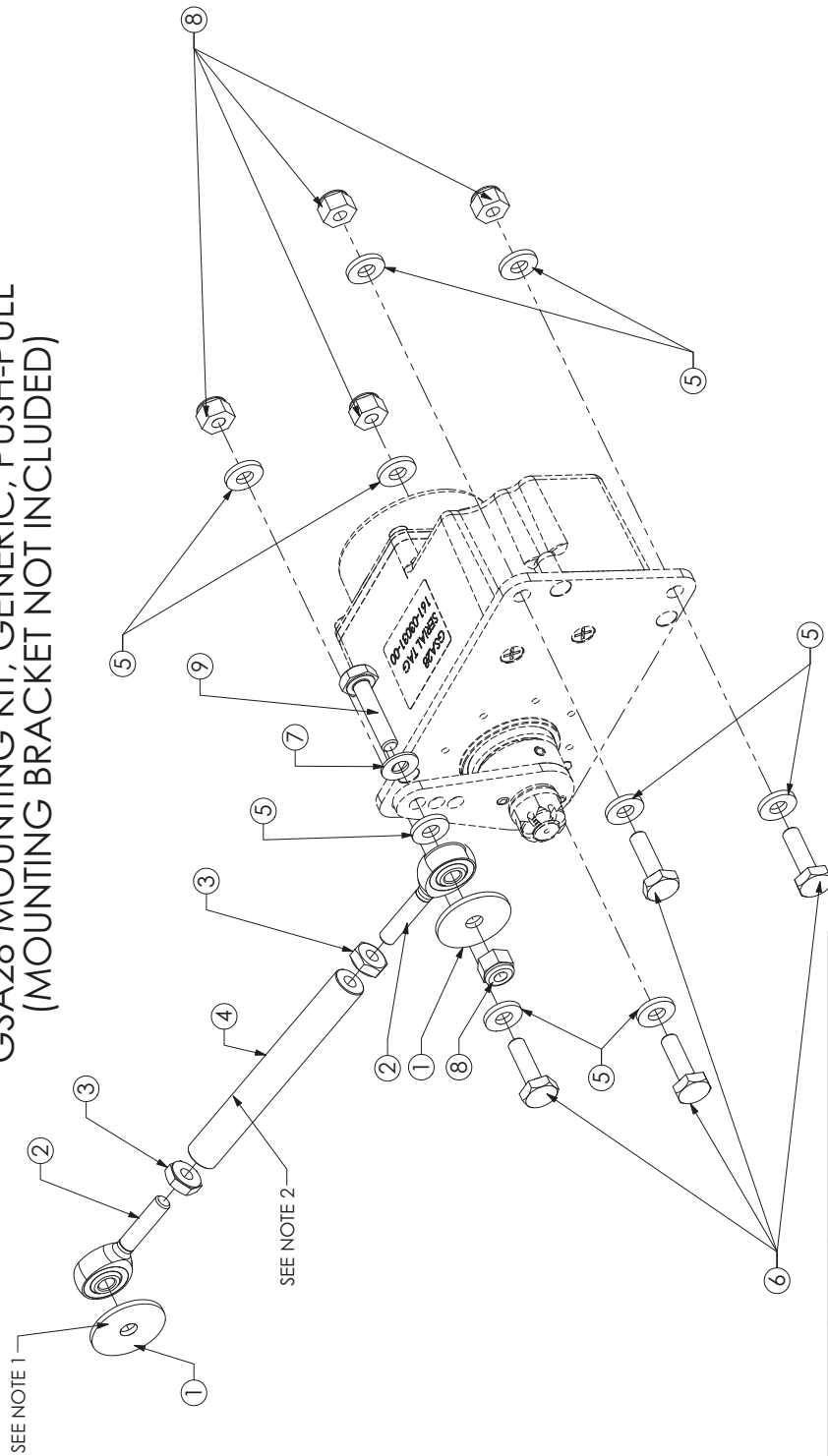

Figure E-8.6 GSA 28 Recommended Mounting Hardware

011-02952-00
GSA28 MOUNTING KIT, GENERIC, PUSH-PULL
 (MOUNTING BRACKET NOT INCLUDED)



- NOTES:
1. PUSH ROD (ITEM 4) IS SUPPLIED 8" LONG AND UNTAPPED. CUT TO DESIRED LENGTH AND TAP # 10-32 THREADS X .61" MIN DEEP IN EACH END. ALLOW ENOUGH LENGTH FOR THREAD ENGAGEMENT BETWEEN PUSH ROD (ITEM 4) AND ROD END (ITEM 2). ACCEPTABLE THREAD ENGAGEMENT BETWEEN ITEM 2 AND 4 IS 0.492" ± .11". IF COTTER PIN IS REMOVE FROM GSA28 CASTLE NUT, DISCARD COTTER PIN AND REPLACE WITH NEW COTTER PIN (ITEM 10) INCLUDED.
 - 2.

ITEM	GARMIN P/N	QTY	DESCRIPTION
1	212-00080-03	2	AN970-3 WASHER
2	382-00019-02	2	MALE ROD END BEARING
3	210-00116-03	2	AN315-3R JAM NUT
4	117-00542-07	1	PUSH ROD, 8.0" UNTAPPED
5	212-00035-10	9	AN960-10 WASHER
6	211-00090-01	4	AN3-5A BOLT
7	212-00043-10	1	AN960-10L (THIN) WASHER
8	210-00117-03	5	AN365-1032A LOCK NUT
9	211-00090-05	1	AN3-7A BOLT
10	231-00034-04	1	COTTER PIN, MS24665-208

Figure E-8.7 GSA 28 Generic, Push-Pull Mounting Kit (No Bracket) 011-02952-00

011-02952-01
GSA28 MOUNTING KIT, GENERIC, PUSH-PULL, W/BRACKET

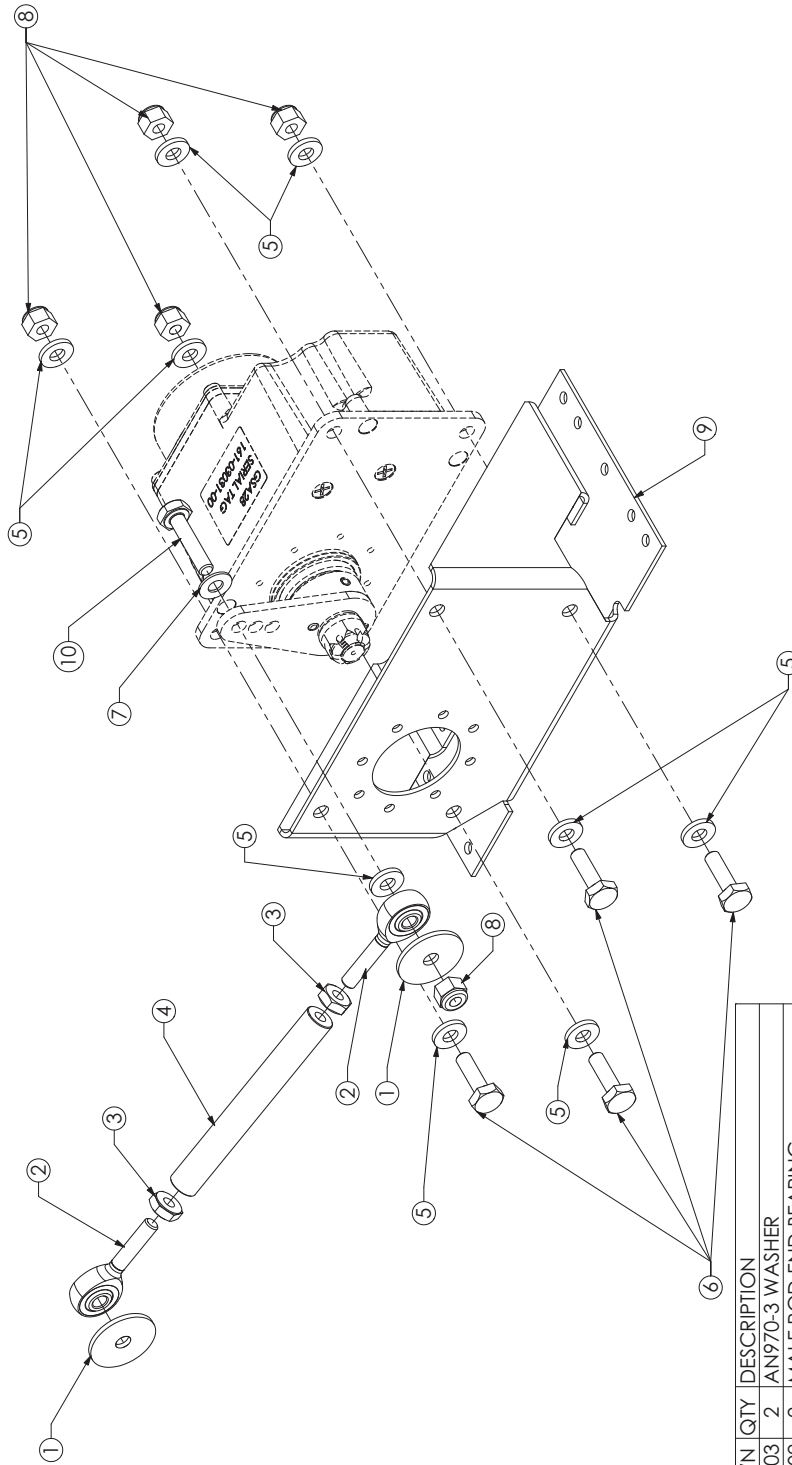

- NOTES:
1. PUSH ROD (ITEM 4) IS SUPPLIED 8" LONG AND UNTAPPED. CUT TO DESIRED LENGTH AND TAP # 10-32 THREADS X .61" MIN DEEP IN EACH END. ALLOW ENOUGH LENGTH FOR THREAD ENGAGEMENT BETWEEN PUSH ROD (ITEM 4) AND ROD END (ITEM 2). ACCEPTABLE THREAD ENGAGEMENT BETWEEN ITEM 2 AND 4 IS 0.492" ±.117". IF COTTER PIN IS REMOVE FROM GSA28 CASTLE NUT, DISCARD COTTER PIN AND REPLACE WITH NEW COTTER PIN (ITEM 11) INCLUDED.
 - 2.

ITEM	GARMIN P/N	QTY	DESCRIPTION
1	212-00080-03	2	AN970-3 WASHER
2	382-00019-02	2	MALE ROD END BEARING
3	210-00116-03	2	AN315-3R JAM NUT
4	117-00542-07	1	PUSH ROD, 8.0" UNTAPPED
5	212-00035-10	9	AN960-10 WASHER
6	211-00090-01	4	AN3-5A BOLT
7	212-00043-10	1	AN960-10L (THIN) WASHER
8	210-00117-03	5	AN365-1032A LOCK NUT
9	115-01854-00	1	GSA28 MOUNTING BRACKET, GENERIC
10	211-00090-05	1	AN3-7A BOLT
11	231-00034-04	1	COTTER PIN, MS24665-208

Figure E-8.8 GSA 28 Generic, Push-Pull Mounting Kit w/Bracket 011-02952-01

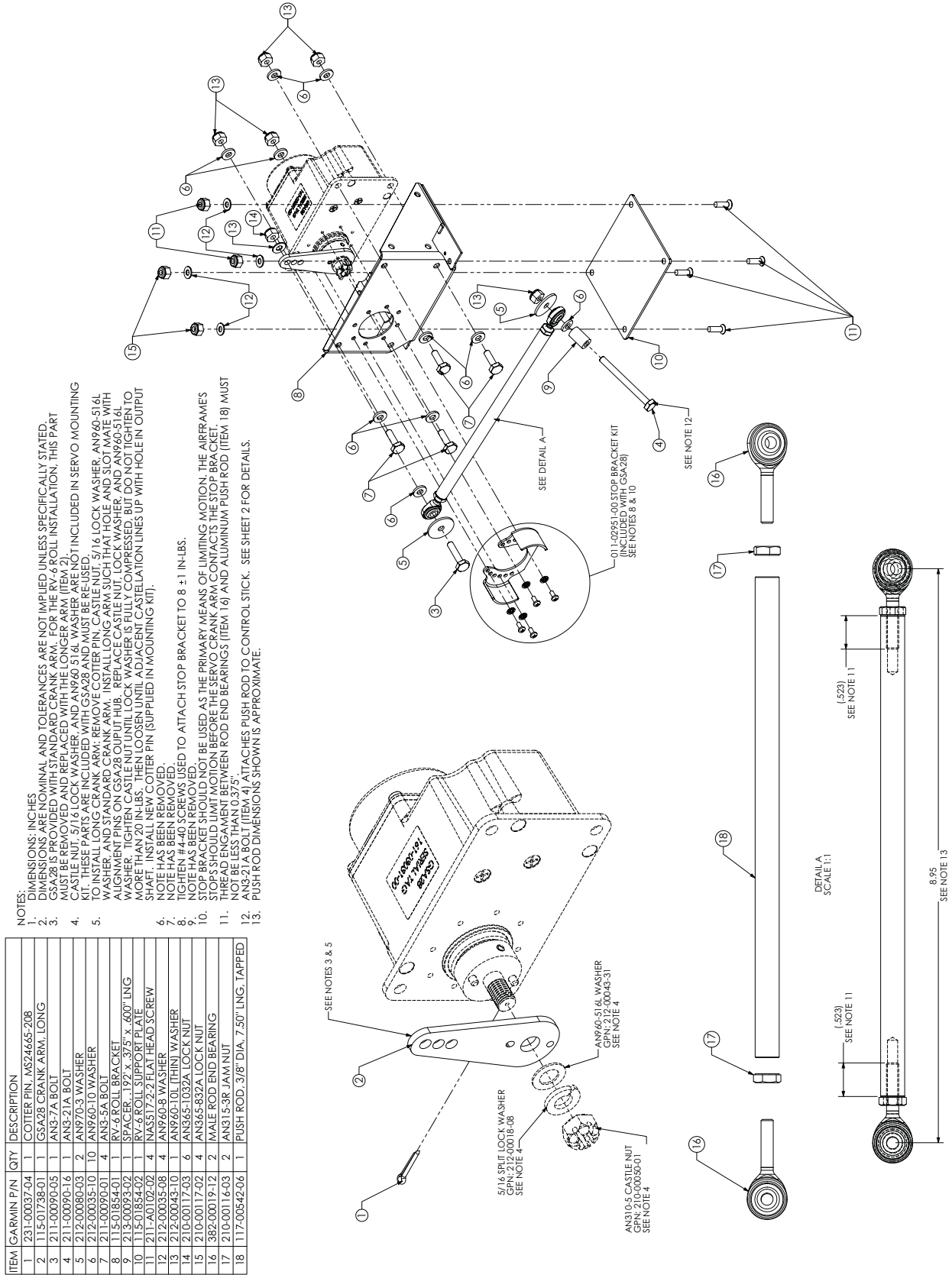

- NOTES:
1. DIMENSIONS ARE NOMINAL AND TOLERANCES ARE NOT IMPLIED UNLESS SPECIFICALLY STATED.
 2. GSA28 IS PROVIDED WITH STANDARD CRANK ARM. FOR THE RV-6 ROLL INSTALLATION, THIS PART MUST BE REMOVED AND REPLACED WITH THE LONGER ARM (ITEM 2).
 3. THE LONGER CRANK ARM (ITEM 2) IS PROVIDED WITH THE LONGER CRANK ARM (ITEM 2).
 4. KIT THESE PARTS ARE INCLUDED WITH GSA28 AND MUST BE REUSED.
 5. TO INSTALL LONG CRANK ARM: REMOVE COTTER PIN, CASTLE NUT, 5/16 LOCK WASHER, AN960-514I WASHER, AND STANDARD CRANK ARM. INSTALL LONG ARM SUCH THAT HOLE AND SLOT MATE WITH ALIGNMENT PINS ON GSA28 OUTPUT HUB. REPLACE CASTLE NUT, LOCK WASHER, AND AN960-514I WASHER. TIGHTEN CASTLE NUT UNTIL LOCK WASHER IS FULLY COMPRESSED, BUT DO NOT TIGHTEN TO MORE THAN 20 IN-LBS. THEN LOOSEN UNTIL ADJACENT CASTELLATION LINES UP WITH HOLE IN OUTPUT SHAFT. INSTALL NEW COTTER PIN (SUPPLIED IN MOUNTING KIT).
 6. NOTE HAS BEEN REMOVED.
 7. NOTE HAS BEEN REMOVED.
 8. TIGHTEN #4-40 SCREWS USED TO ATTACH STOP BRACKET TO 8 ± 1 IN-LBS.
 9. STOP BRACKET SHOULD NOT BE USED AS THE PRIMARY MEANS OF LIMITING MOTION. THE AIRFRAME'S STOP SHOULD LIMIT MOTION BEFORE THE SERVO CRANK ARM CONTACTS THE STOP BRACKET.
 10. THREAD ENGAGEMENT BETWEEN ROD END BEARINGS (ITEM 16) AND ALUMINUM PUSH ROD (ITEM 18) MUST NOT BE LESS THAN 0.375".
 11. 11. ATTACHES PUSH ROD TO CONTROL STICK. SEE SHEET 2 FOR DETAILS.
 12. 12. PUSH ROD DIMENSIONS SHOWN IS APPROXIMATE.
 13. 13.

ITEM	GARMIN P/N	QTY	DESCRIPTION
1	231-00037-04	1	COTTER PIN, MS24665-208
2	115-01738-01	1	GSA28 CRANK ARM, LONG
3	211-00090-05	1	AN3-7A BOLT
4	211-00090-16	1	AN3-21A BOLT
5	212-00080-03	2	AN970-3 WASHER
6	212-00035-10	10	AN960-10 WASHER
7	211-00090-01	4	AN3-5A BOLT
8	115-01854-01	1	RV-6 ROLL BRACKET
9	213-00093-02	1	SPACER, .192" X .375" X .600" LING
10	115-01854-02	1	RV-6 ROLL SUPPORT PLATE
11	211-A0102-02	4	NA3517-2-2 FLAT HEAD SCREW
12	212-00035-08	4	AN960-8 WASHER
13	212-00043-10	1	AN960-10 (THIN) WASHER
14	210-00117-03	6	AN365-1032A LOCK NUT
15	210-00117-02	4	AN365-832A LOCK NUT
16	382-00019-12	2	MALE ROD END BEARING
17	210-00016-03	2	AN315-3R JAW NUT
18	117-00042-06	1	PUSH ROD, 3/8" DIA, 7.50" LING, TAPPED

Figure E-9.1 GSA 28 RV-6 Roll Mounting Kit 011-02952-10 (page 1 of 3)

NOTES:
 1. PUSH ROD CONNECTS DIRECTLY TO CONTROL STICK. REFACE BUSHING BOLT WITH ANS BOLT PROVIDED. TIGHTEN PER AIRFRAME MANUFACTURER'S SPECIFICATION.

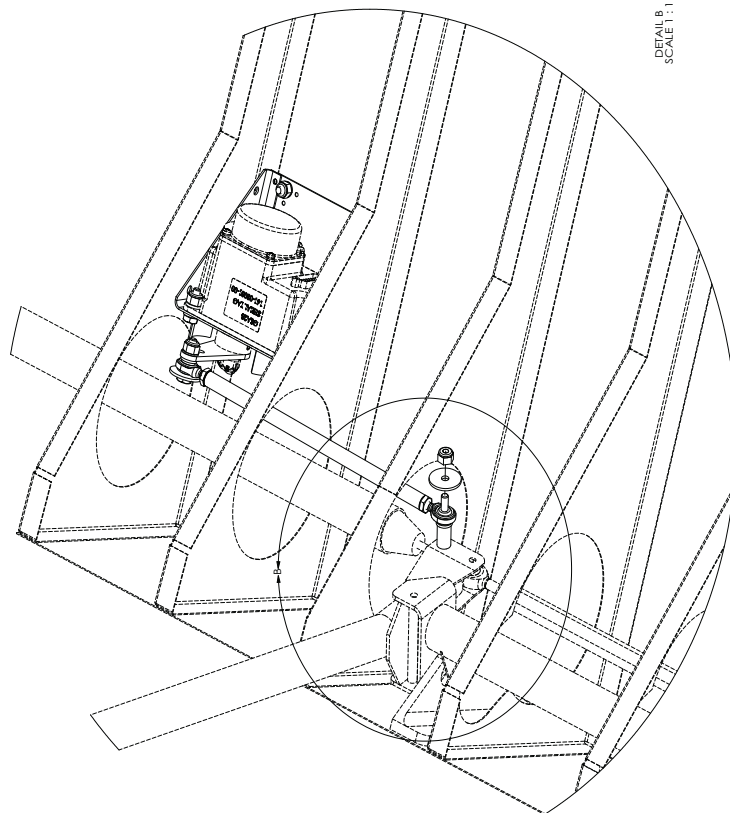
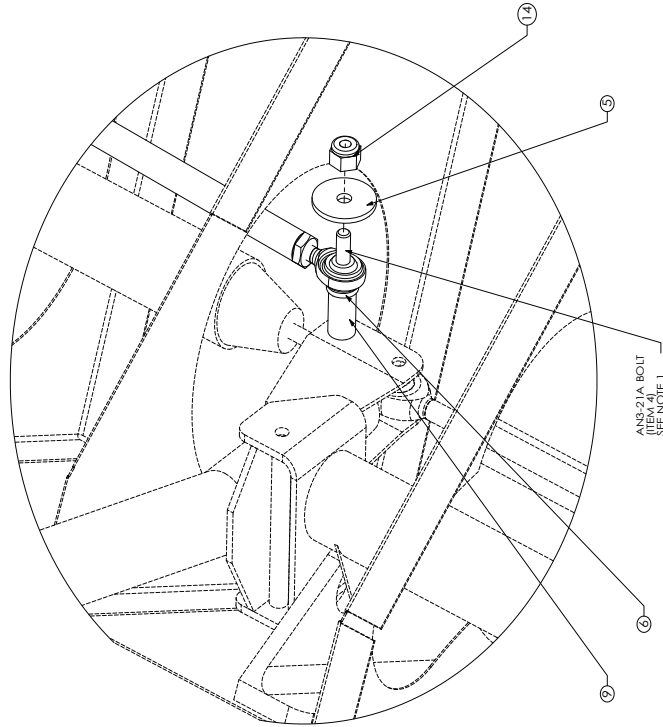

Figure E-9.1 GSA 28 RV-6 Roll Mounting Kit 011-02952-10 (page 2 of 3)

- NOTES:
1. ATTACH MOUNTING BRACKET TO FLOOR AS SHOWN USING SUPPORT PLATE WITH #8 FLAT HEAD SCREWS, WASHERS, AND NUTS PROVIDED OR USE MS21055 CORNER NUT PLATES (NOT INCLUDED). MATCH DRILL THROUGH FLOOR FOR #8 SCREWS ONCE BRACKET LOCATION HAS BEEN DETERMINED.
 2. DIMENSION SHOWN IS APPROXIMATE. IT IS HIGHLY RECOMMENDED SERVO WITH BRACKET AND PUSH ROD BE TESTED FOR PROPER FIT AND FREEDOM OF MOTION ARE VERIFIED PRIOR TO DRILLING MOUNTING HOLES THROUGH FLOOR.
 3. PUSH TUBE CLEARANCE HOLES IN FLOOR RIBS MAY NEED TO BE TRIMMED TO CREATE MORE CLEARANCE FOR SERVO PUSH ROD.

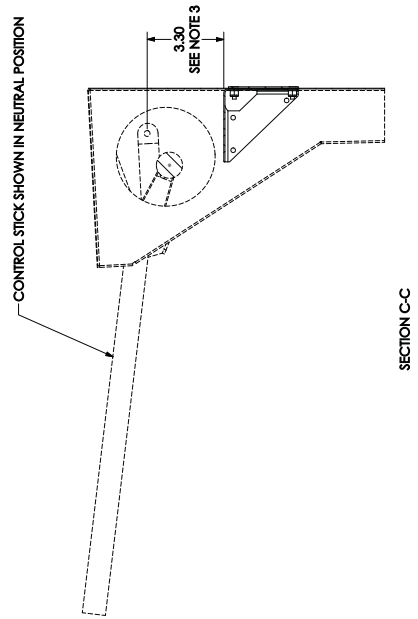
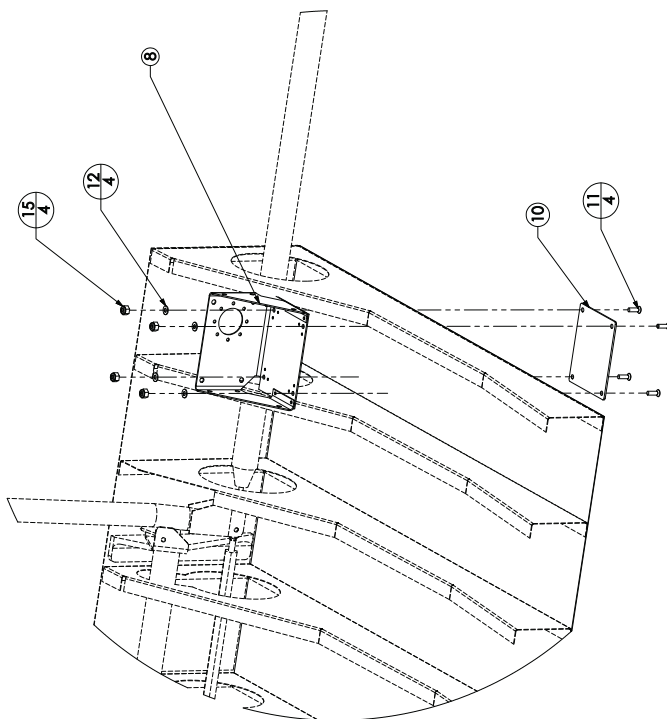

Figure E-9.1 GSA 28 RV-6 Roll Mounting Kit 011-02952-10 (page 3 of 3)

ITEM	GARMIN P/N	QTY	DESCRIPTION	RV-4 & PRE-SEPT 2006 RV-8	POST-SEPT 2006 RV-8
1	210-00117-03	4	AN365-1032A LOCK NUT	X	X
2	212-00035-10	10	AN960-10 WASHER	X	X
3	211-00090-05	1	AN3-7A BOLT	X	X
4	115-01854-03	1	RV-4/8 PITCH BRACKET, LEFT	X	X
5	211-00090-07	1	AN3-11A BOLT	X	X
6	213-00093-03	1	SPACER, 1.92x.375x.75 LING	X	X
7	211-00090-01	1	AN3-5A BOLT	X	X
8	212-00080-03	2	AN970-3 WASHER	X	X
9	115-01854-04	1	RV-4/8 PITCH BRACKET, RIGHT	X	X
10	211-00090-08	1	AN3-14A BOLT	X	X
11	211-00090-09	1	AN3-15A BOLT	X	X
12	382-00019-02	2	MALE ROD END BEARING	X	X
13	210-00116-03	2	AN315-3R JAM NUT	X	X
14	117-00542-00	1	PUSH ROD, 3/8 DIA, 2.25" LING, TAPPED	X	X
15	212-00043-10	1	AN960-10L (PHIN) WASHER	X	X

- NOTES:
1. DIMENSIONS ARE NOMINAL AND TOLERANCES ARE NOT IMPLIED UNLESS SPECIFICALLY STATED.
 2. SPECIFICALLY STATED THROUGH THE BELL CRANK TO ATTACH PUSH ROD. SEE SHEET 7 FOR HOLE SIZE AND LOCATION.
 3. SINGLE AN960-10 WASHER (ITEM 2) MUST BE PLACED IN BETWEEN BELL CRANK AND AIRFRAME KIT. SEE SHEET 7 FOR HOLE SIZE AND LOCATION.
 4. MAIN PUSH ROD PROVIDERS TO BE USED WITH POST-SEPT 2006 RV-8 AIRFRAME KIT. WASHERS FOR AN4 BOLT ARE NOT PROVIDED IN GSA28 MOUNTING KIT. USE PARTS PROVIDED WITH AIRFRAME KIT. TIGHTEN PER AIRFRAME MANUFACTURER'S SPECIFICATION.
 5. THE MAIN PUSH ROD PROVIDER MUST BE REMOVED. NOTE HAS BEEN REMOVED.
 6. THE MAIN PUSH ROD PROVIDER MUST BE REMOVED. NOTE HAS BEEN REMOVED.
 7. THREAD ENGAGEMENT BETWEEN ROD END BEARINGS (ITEM 12) AND ALUMINUM PUSH ROD (ITEM 14) MUST NOT BE LESS THAN 0.375".

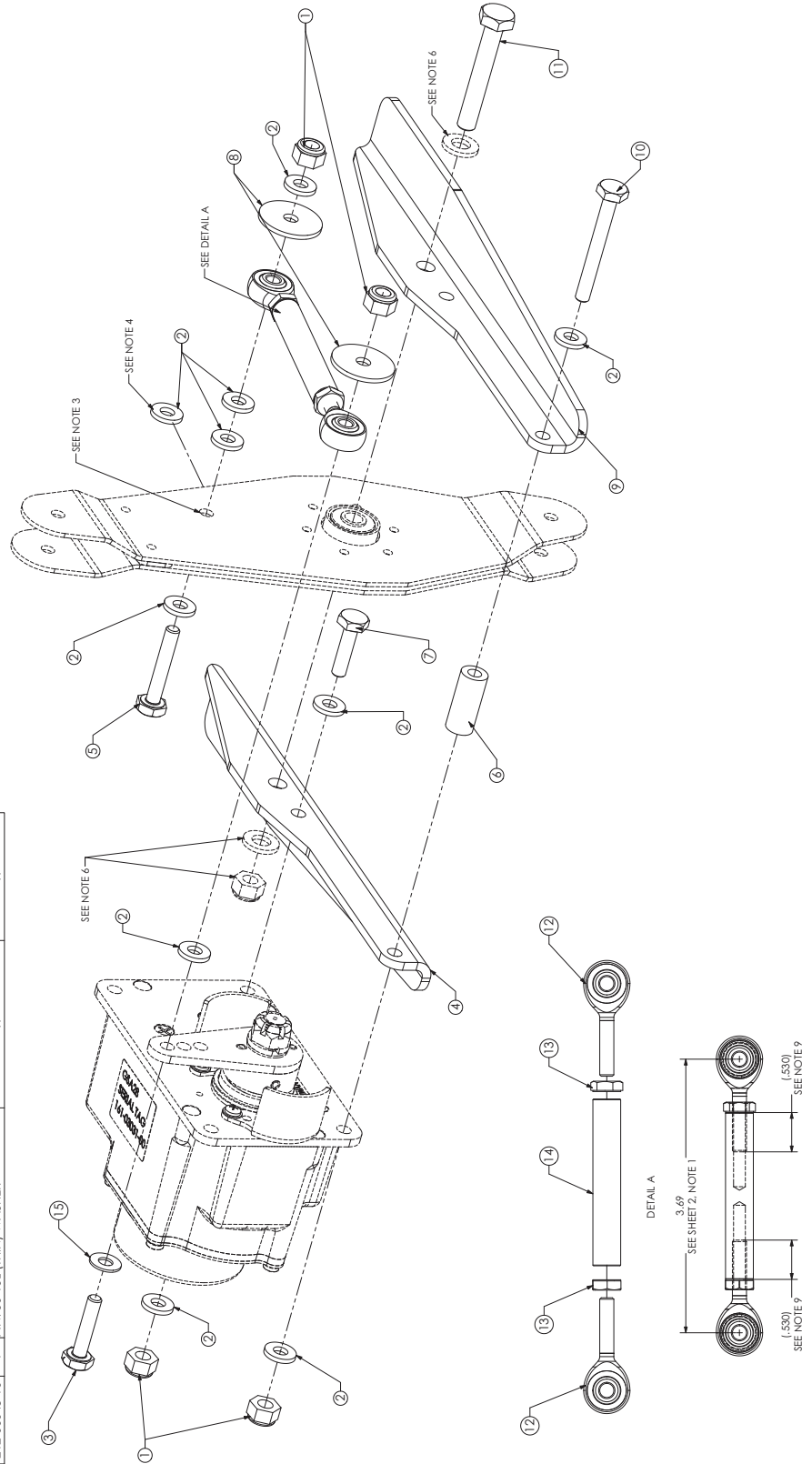
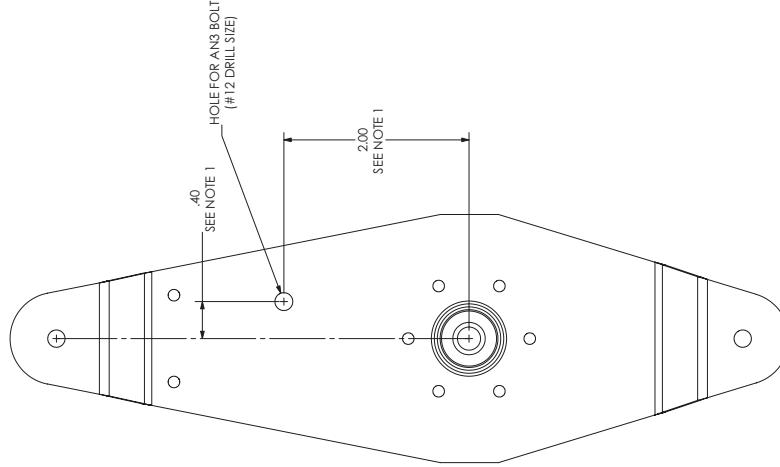
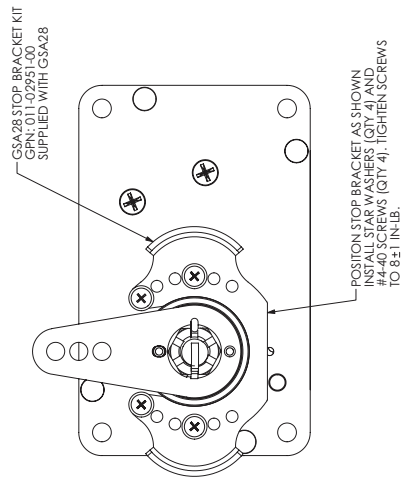

Figure E-10.1 GSA 28 RV-4/8 Pitch Mounting Kit 011-02952-11 (page 1 of 4)

BELL CRANK MODIFICATION, RV-4/8
(ALL VERSIONS)



GSA28 STOP BRACKET POSITION, RV-4/8
(ALL VERSIONS)



NOTES:
1. FOR BEST AUTOPILOT PERFORMANCE, ANGULAR TRAVEL OF THE GSA28 SHOULD BE MAXIMIZED. ARC RADIUS AT ATTACHMENT POINT, SERVO ATTACHMENT POINT, AND PUSH ROD LENGTH ARE SHOWN FOR GUIDANCE ONLY. DEVIATING FROM THIS GUIDANCE IN EFFORT TO INCREASE SERVO TRAVEL IS PERMISSIBLE PROVIDED IT DOES NOT RESULT IN AN OVER-CENTER CONDITION. TO REDUCE THE RISK OF AN OVER-CENTER CONDITION, THE GSA28 SHOULD BE POSITIONED AS SHOWN IN THE INSTALLATION DRAWING. GSA28 STOP BRACKET SHOULD BE POSITIONED AS SHOWN IN THE INSTALLATION DRAWING. CRANK ARM STOPS JUST SHORT OF HITTING THE STOP BRACKET AT FULL TRAVEL IN BOTH DIRECTIONS. BEST CASE SCENARIO WOULD BE TO ACCOMPLISH THIS WITH THE PUSH ROD ATTACHED TO THE OUTERMOST HOLE IN SERVO. IF ANGULAR SERVO TRAVEL CANNOT BE MAXIMIZED USING THE OUTERMOST HOLE, USING THE MIDDLE HOLE IS RECOMMENDED PROVIDED THERE IS NO RISK OF CREATING AN OVER-CENTER CONDITION.

Figure E-10.1 GSA 28 RV-4/8 Pitch Mounting Kit 011-02952-11 (page 2 of 4)

RV-4 AND PRE-SEPTEMBER 2006 RV-8 INSTALLATION

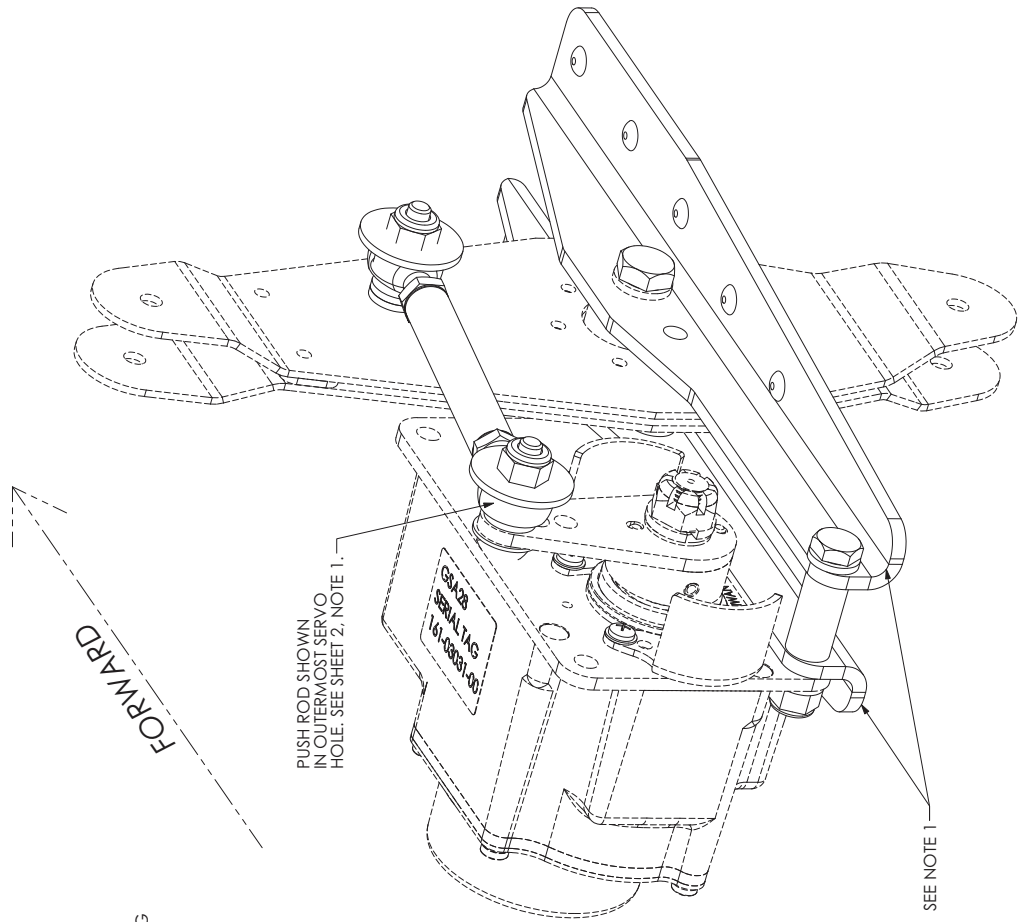

NOTES:
 1. REMOVE EXISTING PITCH BELL CRANK BRACKETS AND REPLACE WITH SERVO MOUNTING BRACKETS (ITEMS 4 AND 9). MATCH-DRILL NEW BRACKETS TO MATCH HOLE PATTERN ON ORIGINAL BRACKET. FASTEN TO AIRFRAME USING ORIGINAL RIVET HOLES. FASTENERS USE FOR MOUNTING THE BRACKETS TO THE AIRFRAME ARE NOT INCLUDED IN MOUNTING KIT.

Figure E-10.1 GSA 28 RV-4/8 Pitch Mounting Kit 011-02952-11 (page 3 of 4)

POST-SEPTEMBER 2006 RV-8 INSTALLATION

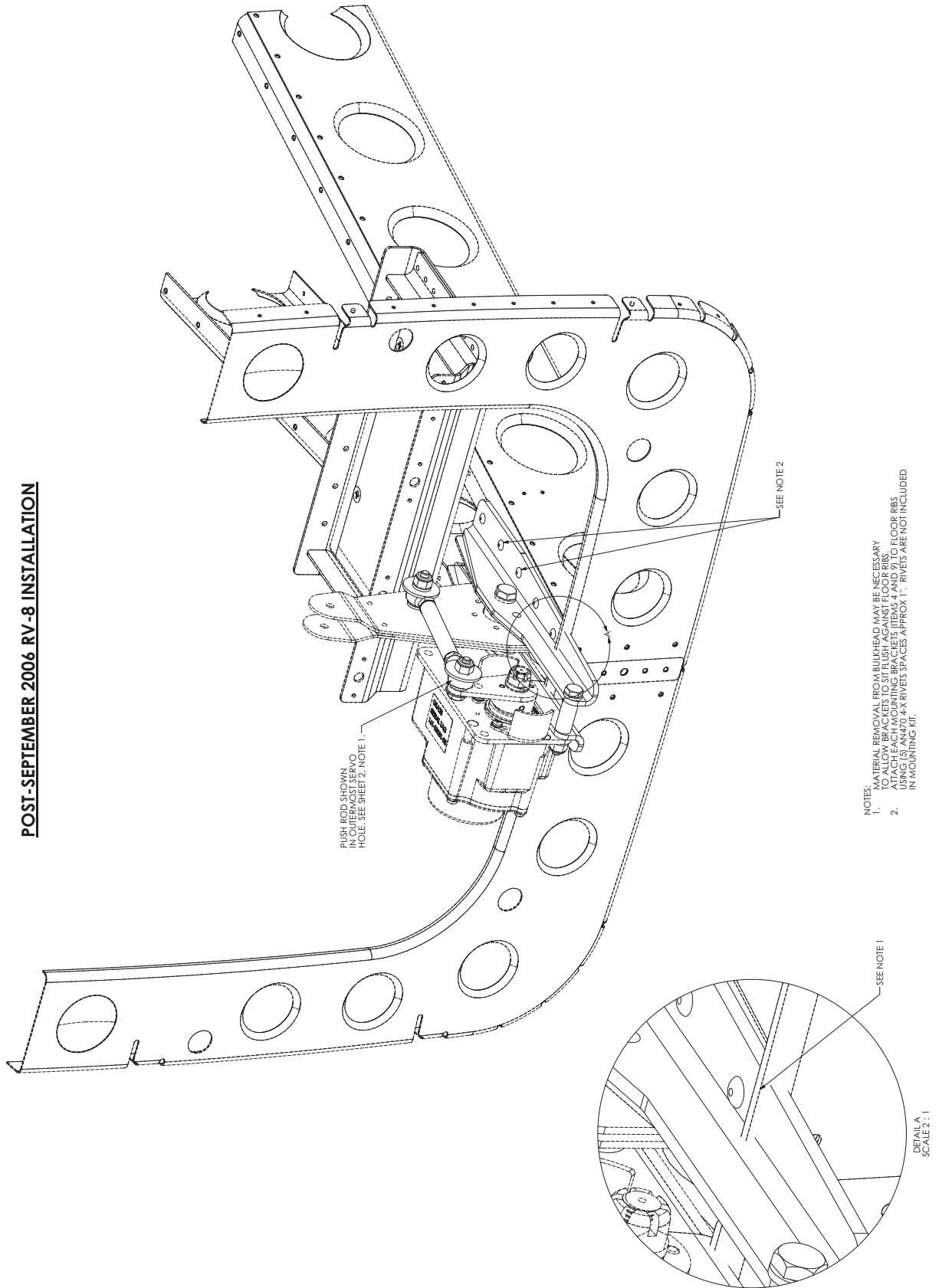
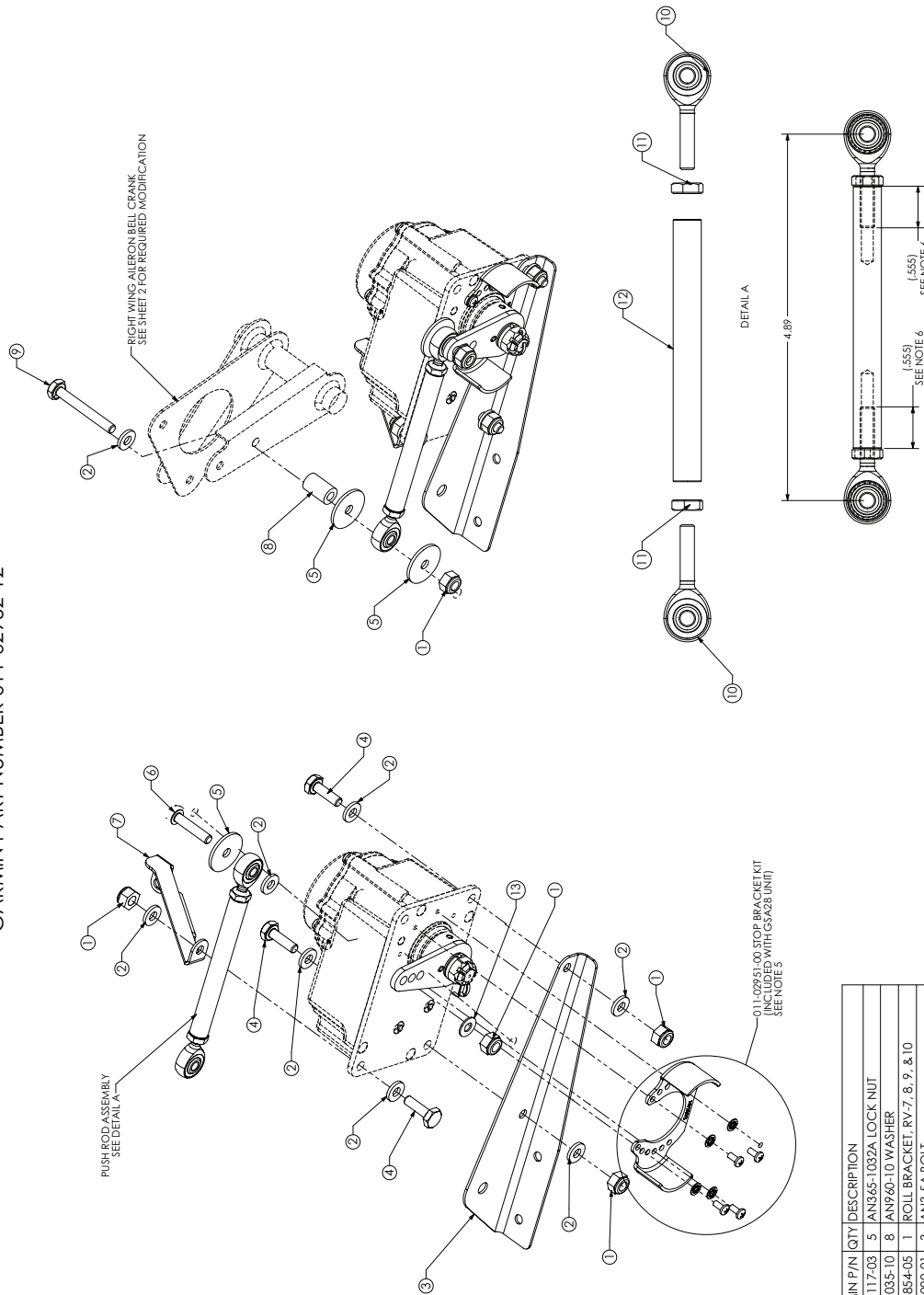

Figure E-10.1 GSA 28 RV-4/8 Pitch Mounting Kit 011-02952-11 (page 4 of 4)

RV-7/8/10 RIGHT WING ROLL MOUNTING KIT FOR GSA28
GARMIN PART NUMBER 011-02952-12



- NOTES:
1. DIMENSIONS IN INCHES. DIMENSIONAL AND TOLERANCES ARE NOT IMPLIED.
 2. DIMENSIONS ARE APPROXIMATE UNLESS SPECIFICALLY STATED.
 3. NOTE HAS BEEN REMOVED.
 4. NOTE HAS BEEN REMOVED.
 5. TIGHTEN #4-40 SCREWS FOR STOP BRACKET TO 8 ± 1 IN.-LBS.
 6. THREAD ENGAGEMENT BETWEEN ROD END (ITEM 10) AND ALUMINUM PUSH ROD (ITEM 12) MUST NOT BE LESS THAN .375".

ITEM	GARMIN P/N	QTY	DESCRIPTION
1	210-00117-03	5	AN365-1032A LOCK NUT
2	212-00035-10	8	AN960-10 WASHER
3	115-01854-05	1	ROLL BRACKET, RV-7, 8, 9, & 10
4	211-00090-01	3	AN3-5A BOLT
5	212-00080-03	3	AN970-3 WASHER
6	211-00090-05	1	AN3-7A BOLT
7	115-01854-06	1	ROLL SUPPORT, RV-7, 8, 9, & 10
8	213-00093-02	1	SPACER, .192" x .375" x .600" LRG
9	211-00090-08	1	AN3-14A BOLT
10	382-00019-02	2	MALE ROD END BEARING
11	210-00116-03	2	AN315-3R JAM NUT
12	117-00542-09	1	PUSH ROD, 3/8" DIA, 3.50" LRG, TAPPED
13	212-00043-10	1	AN960-10L (THIN) WASHER

Figure E-11.1 GSA 28 RV-7/8/10 Roll Mounting Kit 011-02952-12 (page 1 of 2)

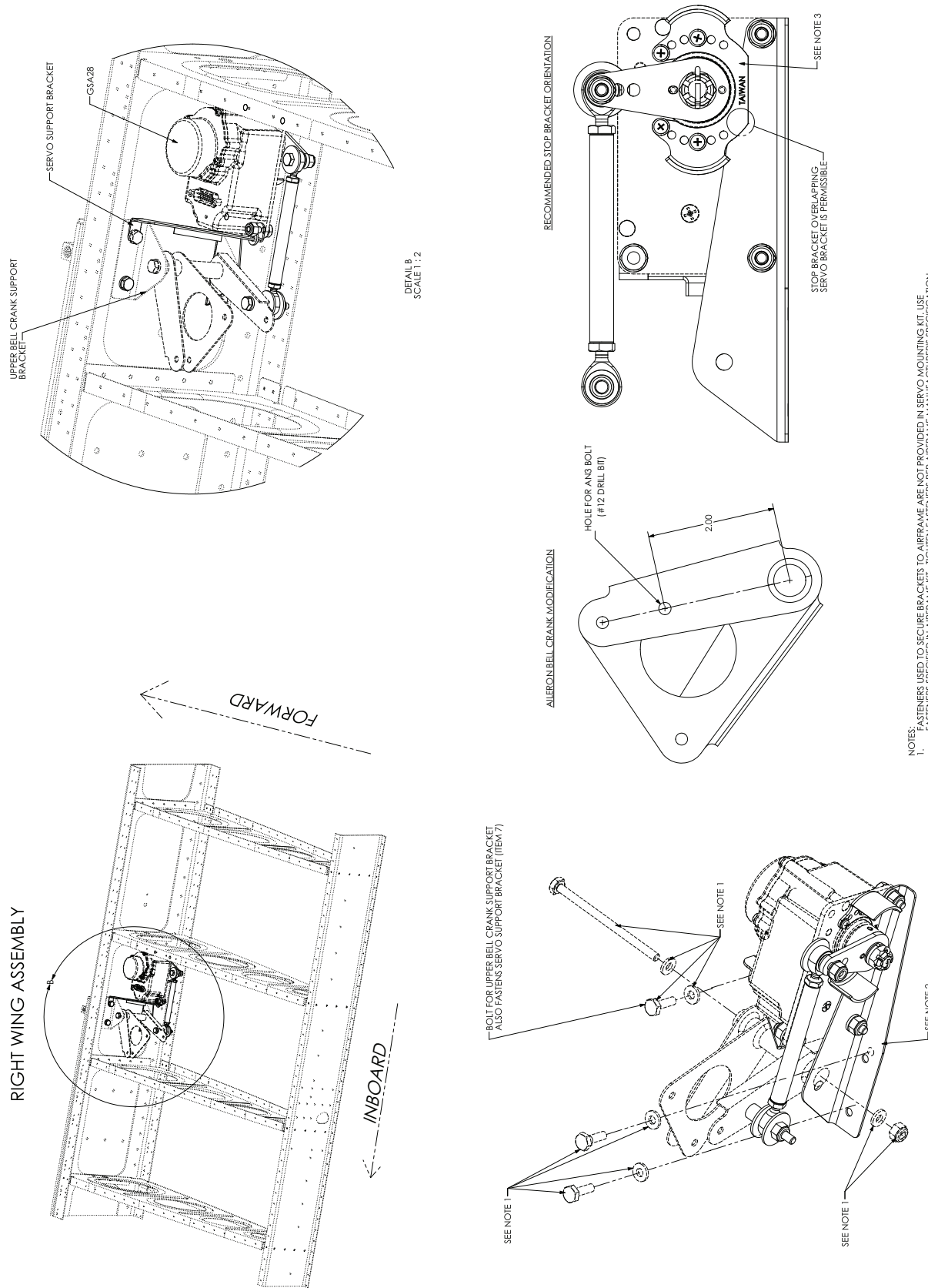
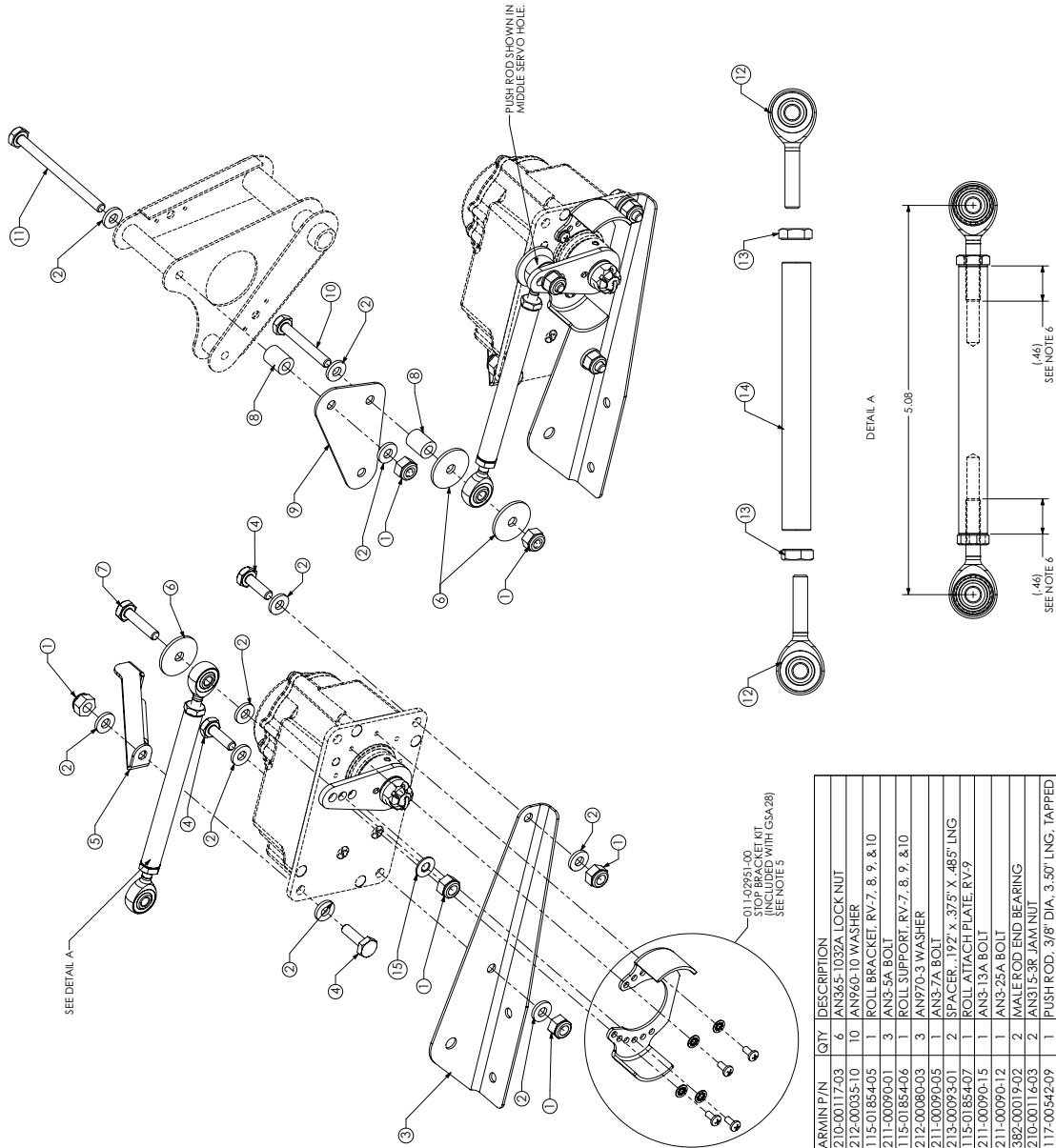

Figure E-11.1 GSA 28 RV-7/8/10 Roll Mounting Kit 011-02952-12 (page 2 of 2)

RV-9 RIGHT WING ROLL MOUNTING KIT
GARMIN PART NUMBER 011-02952-13



- NOTES:
1. DIMENSIONS: INCHES
 2. DIMENSIONS ARE NOMINAL AND TOLERANCES ARE NOT IMPLIED UNLESS SPECIFICALLY STATED.
 3. NOTE DELETED.
 4. NOTE DELETED.
 5. TIGHTEN #4-40 SCREWS FOR STOP BRACKET TO 8 ±1 IN.LBS.
 6. THREAD ENGAGEMENT BETWEEN ROD END (ITEM 12) AND ALUMINUM PUSH ROD (ITEM 14) MUST NOT BE LESS THAN .375".

ITEM	GARMIN P/N	QTY	DESCRIPTION
1	210-00117-03	6	AN365-1032A LOCK NUT
2	212-00035-10	10	AN960-10 WASHER
3	115-01854-05	1	ROLL BRACKET, RV-7, 8, 9, & 10
4	211-00090-01	3	AN3-5A BOLT
5	115-01854-06	1	ROLL SUPPORT, RV-7, 8, 9, & 10
6	212-00080-03	3	AN970-3 WASHER
7	211-00090-05	1	AN3-7A BOLT
8	213-00093-01	2	SPACER, .192" X .375" X .485" LING
9	115-01854-07	1	ROLL ATTACH PLATE, RV-9
10	211-00090-15	1	AN3-13A BOLT
11	211-00090-12	1	AN3-25A BOLT
12	382-00019-02	2	MALE ROD END BEARING
13	210-00114-03	2	AN315-38 JAM NUT
14	117-00542-09	1	PUSH ROD, 3/8" DIA, 3.50" LING, TAPPED
15	212-00043-10	1	AN960-10L (THIN) WASHER

Figure E-12.1 GSA 28 RV-9 Roll Mounting Kit 011-02952-13 (page 1 of 2)

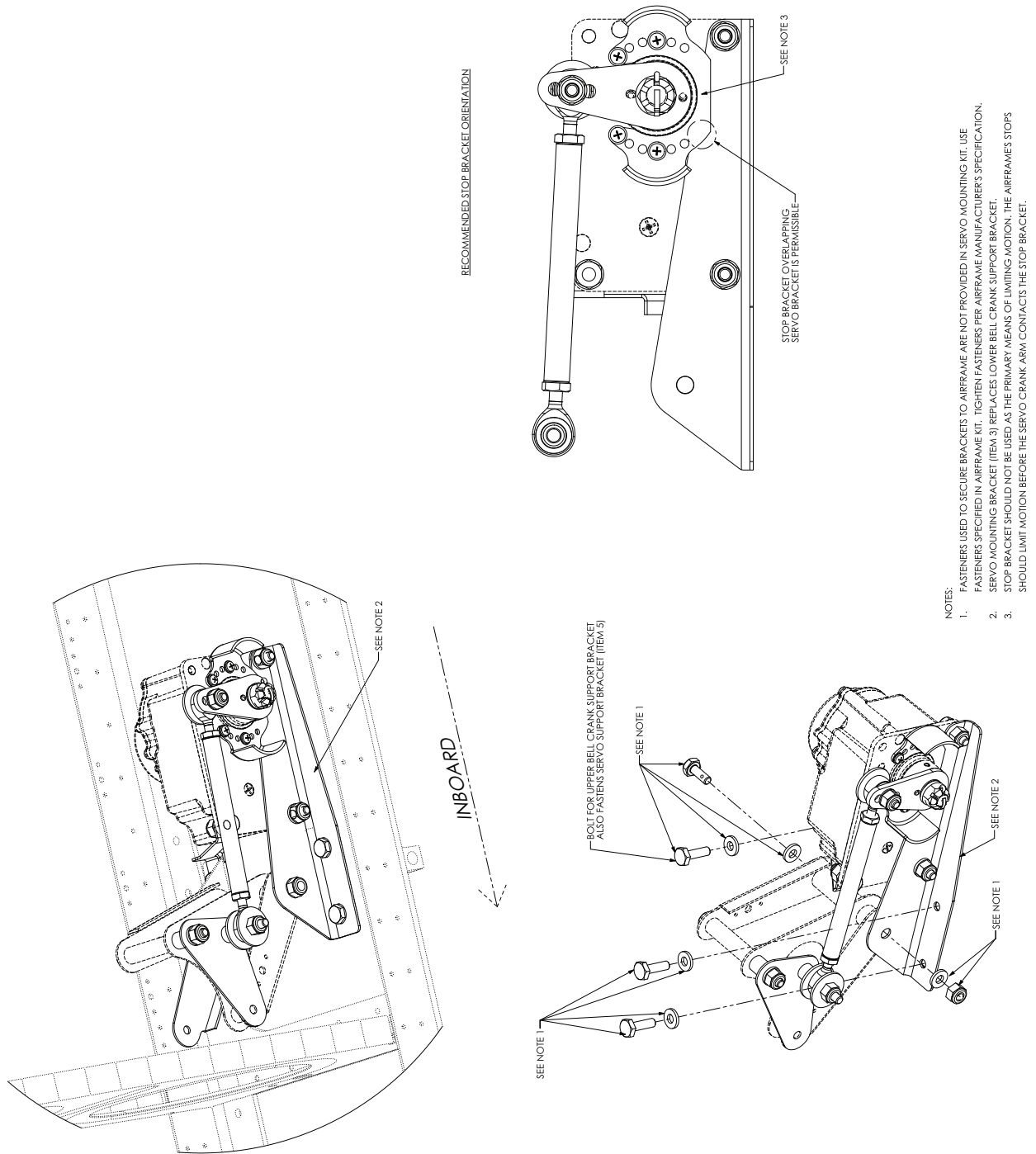
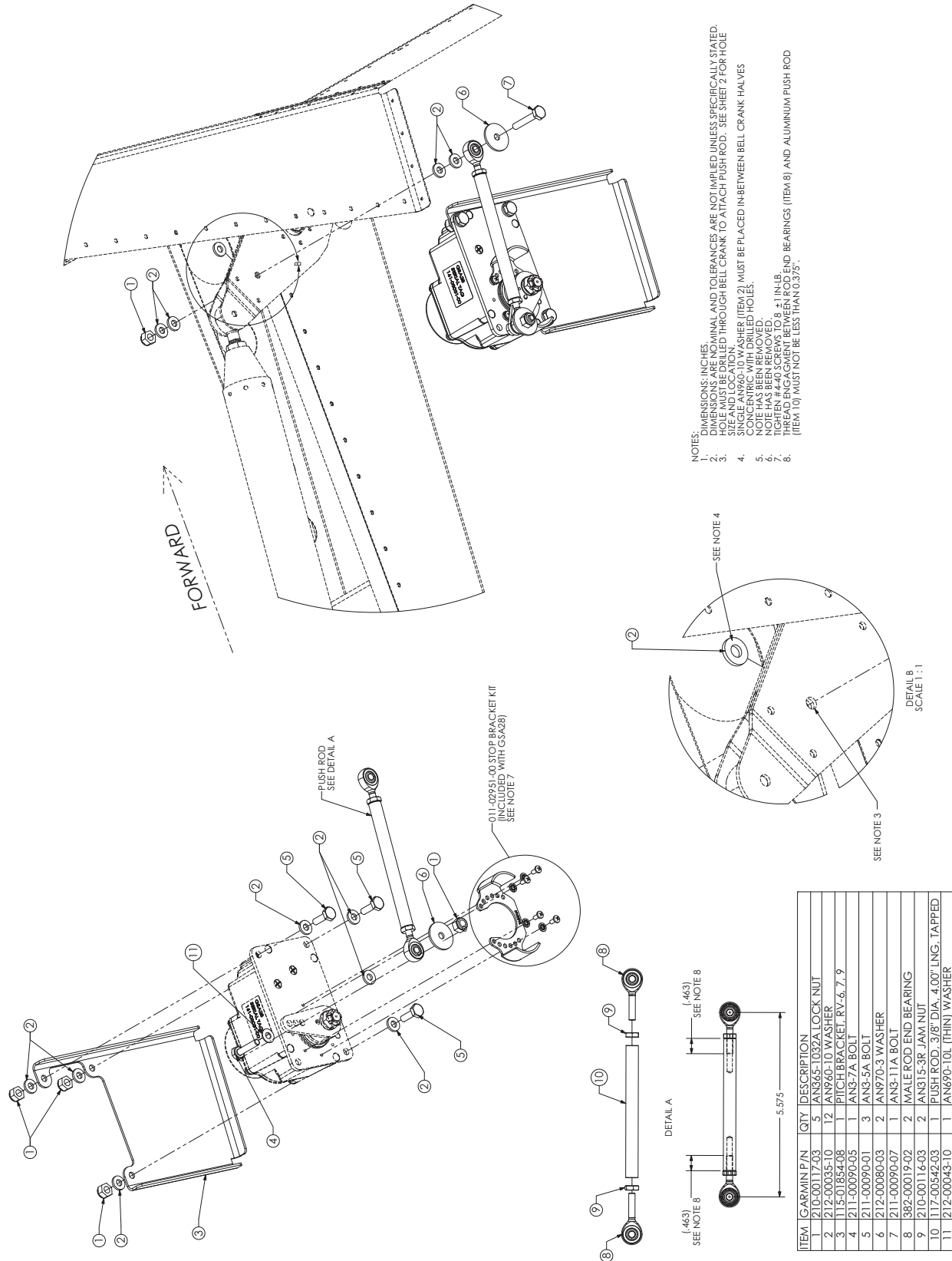
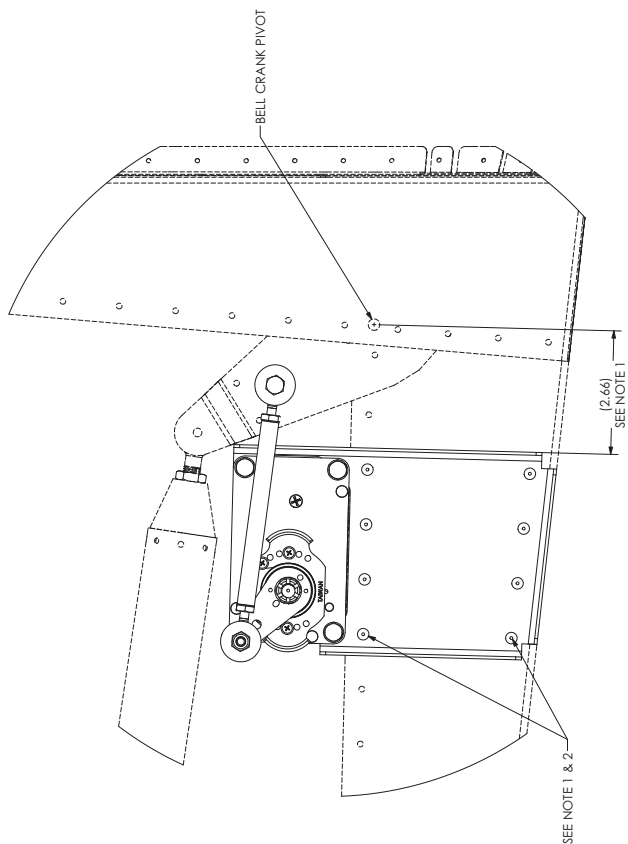
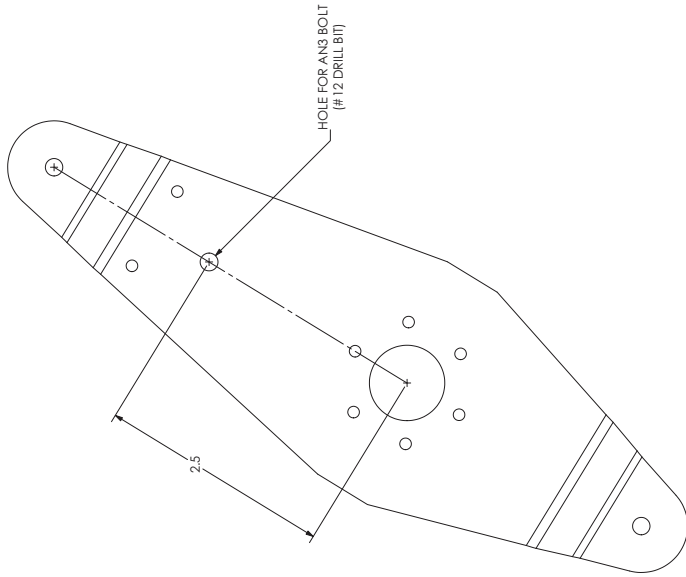

Figure E-12.1 GSA 28 RV-9 Roll Mounting Kit 011-02952-13 (page 2 of 2)



NOTES:
 1. DIMENSIONS IN INCHES.
 2. DIMENSIONS ARE NOMINAL AND TOLERANCES ARE NOT IMPLIED UNLESS SPECIFICALLY STATED.
 3. HOLE MUST BE DRILLED THROUGH BELL CRANK TO ATTACH PUSH ROD. SEE SHEET 2 FOR HOLE SIZE AND LOCATION.
 4. SEE DETAIL A FOR BELL CRANK (ITEM 2) MUST BE PLACED IN BETWEEN BELL CRANK HALVES CONCENTRIC WITH DRILLED HOLE.
 5. NOTE HAS BEEN REMOVED.
 6. NOTE HAS BEEN REMOVED.
 7. THE CLEARANCE BETWEEN ROD END BEARINGS (ITEM 8) AND ALUMINUM PUSH ROD (ITEM 10) MUST NOT BE LESS THAN 0.375".

Figure E-13.1 GSA 28 RV-6/7/9 Mounting Kit 011-02952-14 (page 1 of 2)



SCALE 1:1

RECOMMENDED STOP BRACKET ORIENTATION

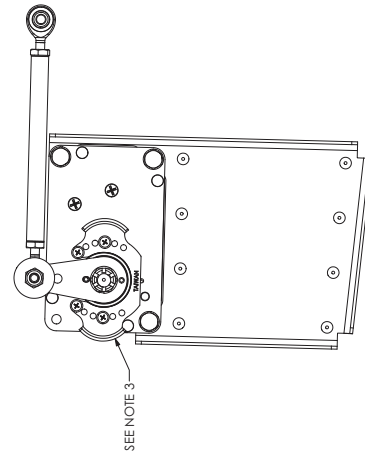

- NOTES:
1. BRACKET LOCATION IS SHOWN CENTERED OVER 3, 4, 5, & 6 PRE-PUNCHED RIVET HOLES AFT OF THE BELL CRANK PIVOT. THIS IS THE RECOMMENDED BRACKET LOCATION. DIMENSION IS SHOWN FOR REFERENCE ONLY.
 2. ATTACH MOUNTING BRACKET TO AIRFRAME FLOOR RIB USING A MINIMUM RIVET OR BOLT. DO NOT USE PRE-PUNCHED RIVETS OR BOLT.
 3. STOP BRACKET SHOULD NOT BE USED AS THE PRIMARY MEANS OF LIMITING MOTION. THE AIRFRAME'S STOPS SHOULD LIMIT MOTION BEFORE THE SERVO CRANK ARM CONTACTS THE STOP BRACKET.

Figure E-13.1 GSA 28 RV-6/7/9 Pitch Mounting Kit 011-02952-14 (page 2 of 2)

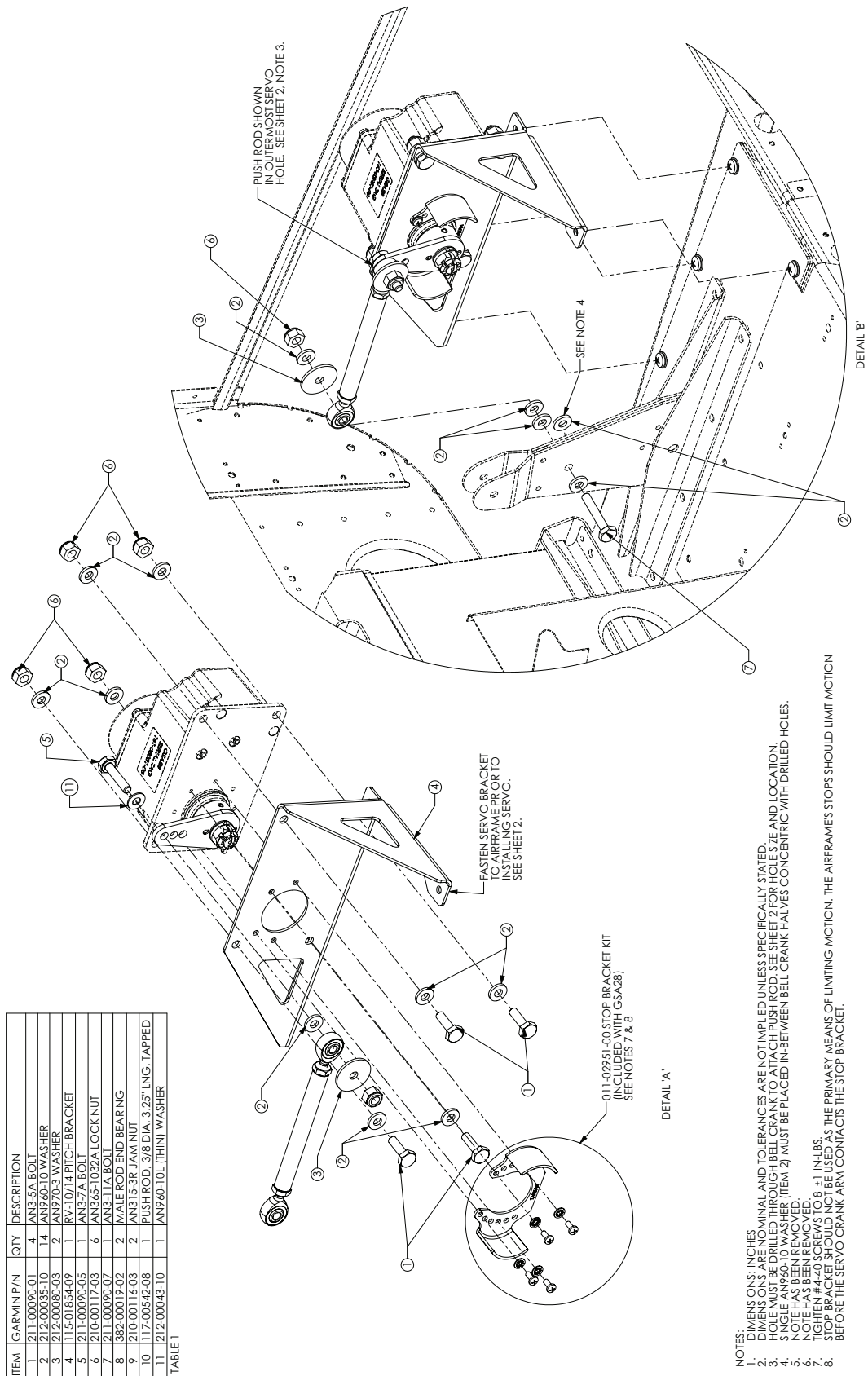
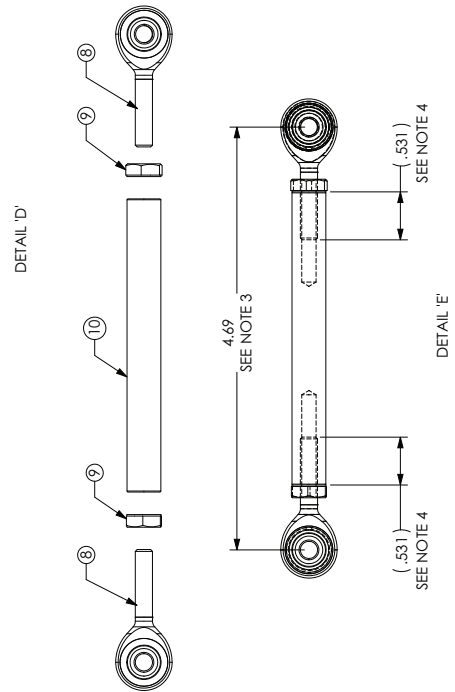
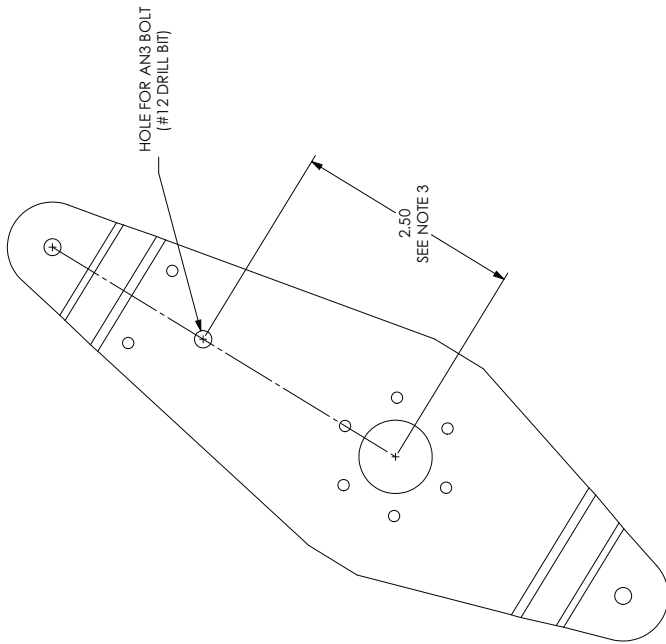
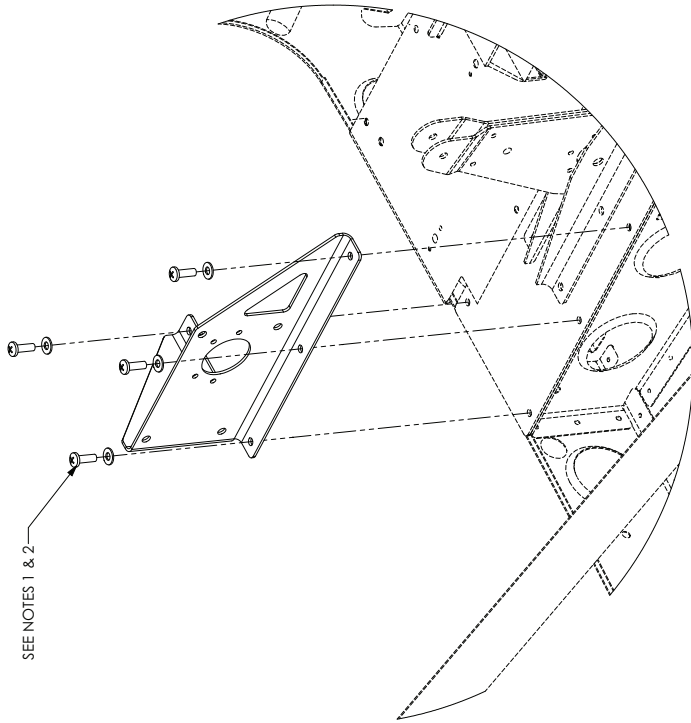
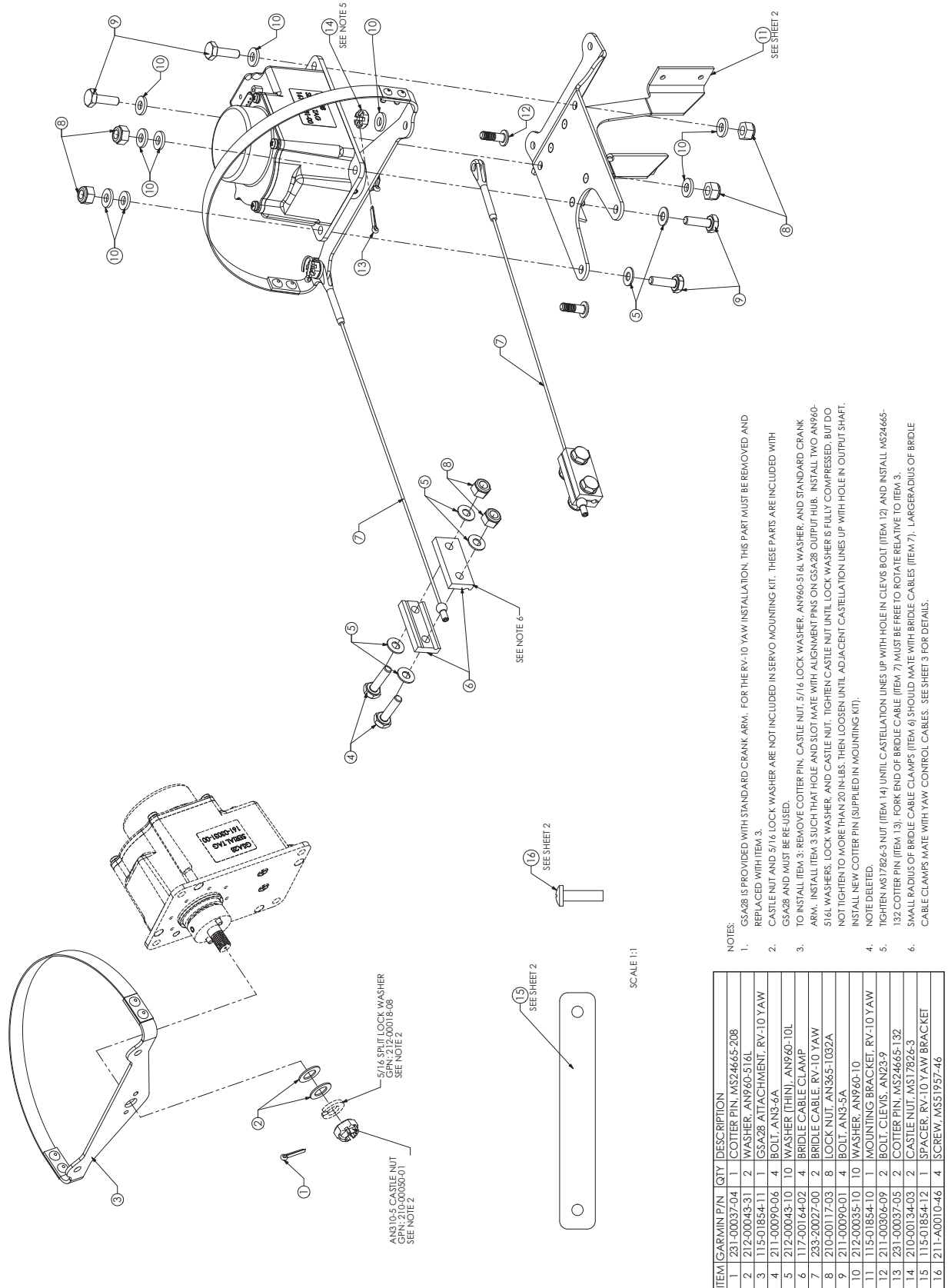

Figure E-14.1 GSA 28 RV-10 Pitch Mounting Kit 011-02952-15 (page 1 of 2)



- NOTE:
1. MOUNTING BRACKET SHOULD BE FASTENED TO AIRFRAME PRIOR TO INSTALLING SERVO.
 2. HOLES IN SERVO MOUNTING BRACKET ALIGN WITH EXISTING HOLES IN AIRFRAME. REMOVE FASTENERS FROM THESE HOLES TO MOUNT BRACKET TO AIRFRAME. RE-USE THESE FASTENERS TO ATTACH SERVO BRACKET. TIGHTEN PER AIRFRAME MANUFACTURER'S SPECIFICATION.
 3. FOR BEST AUTOPILOT PERFORMANCE, ANGULAR TRAVEL OF THE GSA28 SHOULD BE MAXIMIZED. IT IS HIGHLY RECOMMENDED THE GSA28 STOP BRACKET BE USED TO AVOID AN OVER-CENTER CONDITION. WITH THE GSA28 STOP BRACKET INSTALLED, IT IS RECOMMENDED THE SERVO CRANK ARM STOPS JUST SHORT OF HITTING THE STOP BRACKET AT FULL TRAVEL IN BOTH DIRECTIONS. BEST CASE SCENARIO WOULD BE TO ACCOMPLISH THIS WITH THE PUSH ROD ATTACHED TO THE OUTERMOST HOLE. AIRCRAFT ATTACHMENT POINTS AND PUSH ROD LENGTH SHOWN IN DETAIL 'C' AND 'E' ARE FOR GUIDANCE ONLY. DEVIATE AS NECESSARY TO INCREASE SERVO TRAVEL. IF ANGULAR SERVO TRAVEL CANNOT BE MAXIMIZED USING THE OUTERMOST HOLE IN SERVO, USING THE MIDDLE HOLE IS RECOMMENDED PROVIDED THERE IS NO RISK OF CREATING AN OVER-CENTER CONDITION.
 4. THREAD ENGAGEMENT BETWEEN ROD END BEARINGS (ITEM 8) AND ALUMINUM PUSH ROD (ITEM 10) MUST NOT BE LESS THAN 0.375".

Figure E-14.1 GSA 28 RV-10 Pitch Mounting Kit 011-02952-15 (page 2 of 2)



- NOTES:
1. GSA28 IS PROVIDED WITH STANDARD CRANK ARM. FOR THE RV-10 YAW INSTALLATION, THIS PART MUST BE REMOVED AND REPLACED WITH ITEM 3.
 2. CASTLE NUT AND 5/16\"/>

ITEM	GARMIN P/N	QTY	DESCRIPTION
1	231-00037-04	1	COTTER PIN, MS24665-208
2	212-00043-31	2	WASHER, AN960-516L
3	115-01854-11	1	GSA28 ATTACHMENT, RV-10 YAW
4	211-00090-06	4	BOLT, AN3-6A
5	212-00043-10	10	WASHER (THIN), AN960-10L
6	117-00164-02	4	BRIDLE CABLE CLAMP
7	233-20027-00	2	BRIDLE CABLE, RV-10 YAW
8	210-00117-03	8	LOCK NUT, AN365-1032A
9	211-00090-01	4	BOLT, AN3-5A
10	212-00035-10	10	WASHER, AN960-10
11	115-01854-10	1	MOUNTING BRACKET, RV-10 YAW
12	211-00306-09	2	BOLT, CLEVIS, AN23-9
13	231-00037-05	2	COTTER PIN, MS24665-132
14	210-00134-03	2	CASTLE NUT, MS17826-3
15	115-01854-12	1	SPACER, RV-10 YAW BRACKET
16	211-A0010-46	4	SCREW, MS51957-46

Figure E-15.1 GSA 28 RV-10 Yaw Mounting Kit 011-02952-16 (page 1 of 3)

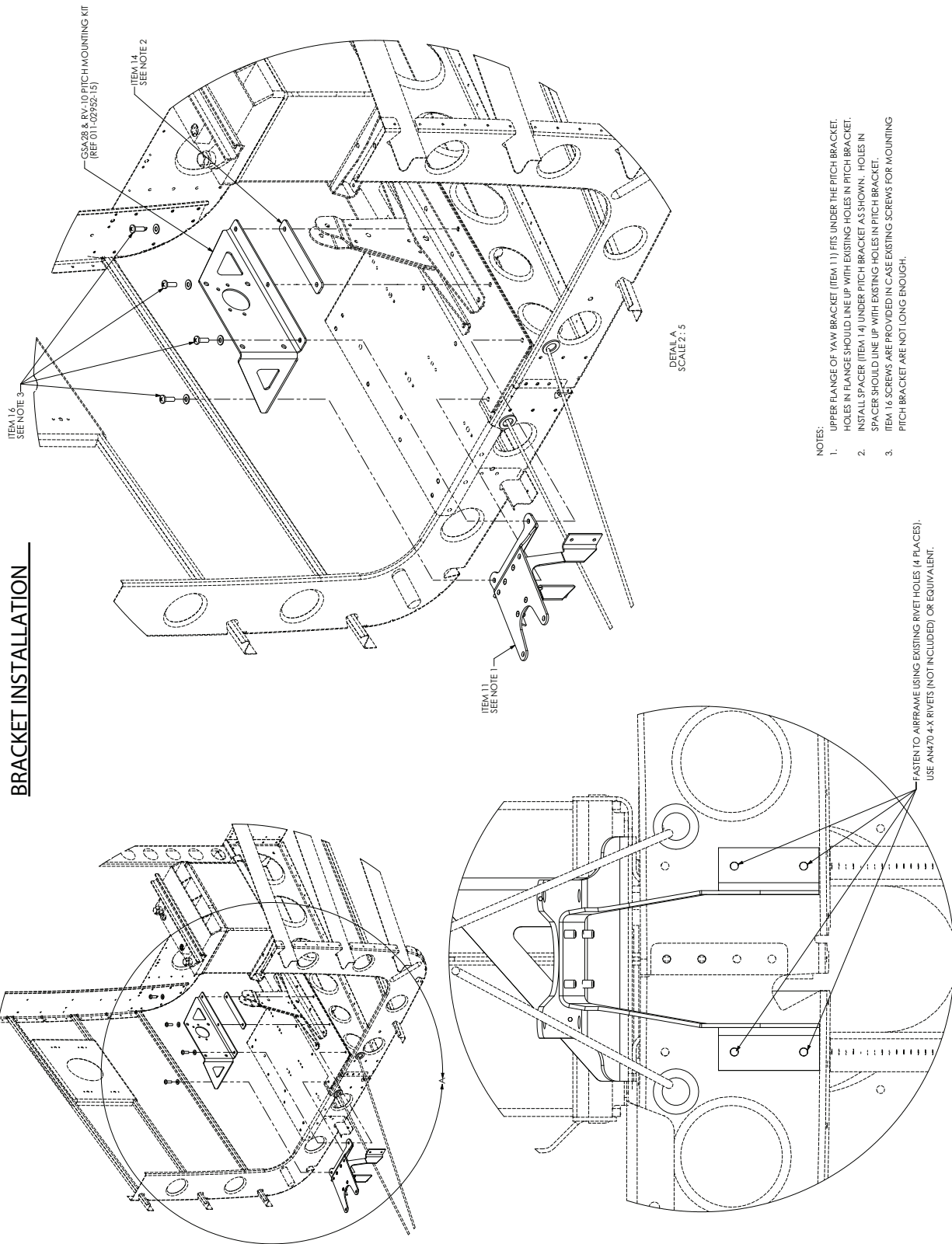

BRACKET INSTALLATION

- NOTES:
1. UPPER FLANGE OF YAW BRACKET (ITEM 11) FITS UNDER THE PITCH BRACKET. HOLES IN FLANGE SHOULD LINE UP WITH EXISTING HOLES IN PITCH BRACKET.
 2. INSTALL SPACER (ITEM 14) UNDER PITCH BRACKET AS SHOWN. HOLES IN SPACER SHOULD LINE UP WITH EXISTING HOLES IN PITCH BRACKET.
 3. ITEM 16 SCREWS ARE PROVIDED IN CASE EXISTING SCREWS FOR MOUNTING PITCH BRACKET ARE NOT LONG ENOUGH.

Figure E-15.1 GSA 28 RV-10 Yaw Mounting Kit 011-02952-16 (page 2 of 3)

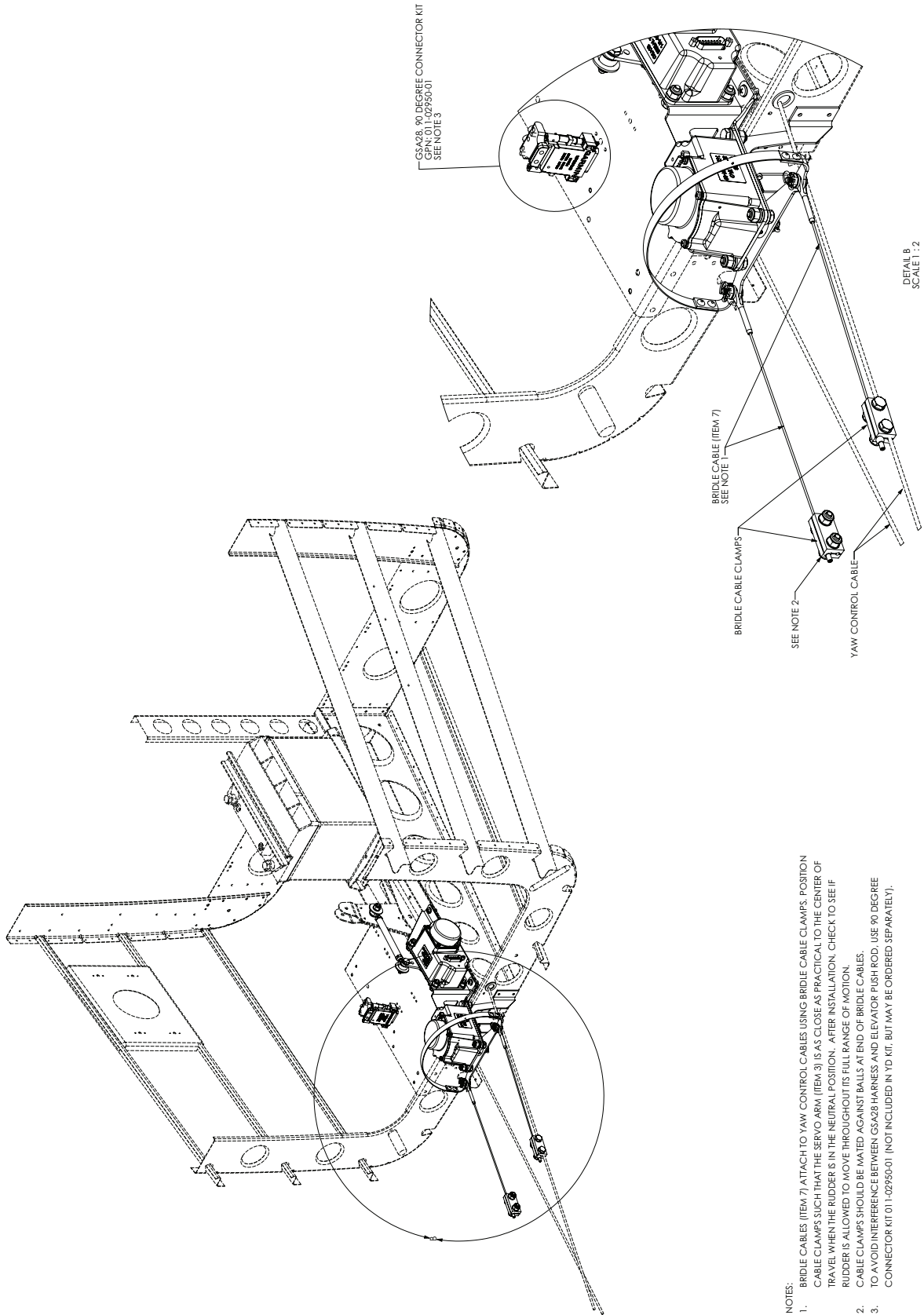

- NOTES:
1. BRIDLE CABLES (ITEM 7) ATTACH TO YAW CONTROL CABLES USING BRIDLE CABLE CLAMPS. POSITION CABLE CLAMPS SUCH THAT THE SERVO ARM (ITEM 3) IS AS CLOSE AS PRACTICAL TO THE CENTER OF TRAVEL WHEN THE RUDDER IS IN THE NEUTRAL POSITION. AFTER INSTALLATION, CHECK TO SEE IF RUDDER IS ALLOWED TO MOVE THROUGHOUT ITS FULL RANGE OF MOTION.
 2. CABLE CLAMPS SHOULD BE MATED AGAINST BALLS AT END OF BRIDLE CABLES.
 3. TO AVOID INTERFERENCE BETWEEN GSA28 HARNESS AND ELEVATOR PUSH ROD, USE 90 DEGREE CONNECTOR KIT 011-02950-01 (NOT INCLUDED IN YD KIT, BUT MAY BE ORDERED SEPARATELY).

Figure E-15.1 GSA 28 RV-10 Yaw Mounting Kit 011-02952-16 (page 3 of 3)

E.8 Connector Pins

E.8.1 J281 Connector

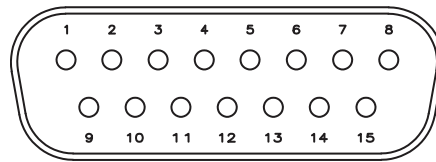

Figure E-16 J281 on GSA 28, as viewed looking at connector on unit

Pin	Pin Name	I/O
1	CAN_H	I/O
2	CAN_L	I/O
3	CAN_TERM_1	--
4	CAN_TERM_2	--
5	ID_STRAP_1	In
6	ID_STRAP_2	In
7	ID_STRAP_3/(RS-232 TX for Roll Servo Only)	In
8	ID_STRAP_4/(RS-232 RX for Roll Servo Only)	In
9	AIRCRAFT GROUND	--
10	AIRCRAFT POWER	In
11	TRIM_IN_1	In
12	TRIM_IN_2	In
13	TRIM_OUT_1	Out
14	TRIM_OUT_2	Out
15	CWS/DISCONNECT	In

E.8.2 Power Function

Supply voltage (14/28Vdc) inputs.

Pin Name	Connector	Pin	I/O
AIRCRAFT POWER	J281	10	In
AIRCRAFT GROUND	J281	9	--

E.8.3 CWS/Disconnect

CWS/Disconnect should be connected to an active low push-button switch that disengages the autopilot, and optionally engages it, if configured. Press and hold the switch to allow for control wheel steering by disengaging the clutch and servo motor. The CWS/Disconnect input must be connected to both the pitch and the roll servos, and can optionally be connected to the yaw damper servo.

Pin Name	Connector	Pin	I/O
CWS/DISCONNECT	J281	15	In

E.8.4 CAN Bus

This data bus conforms to the BOSCH standard for Controller Area Network 2.0-B. This bus complies with ISO 11898. See [Section 2.2.3](#) for CAN Bus details.

Pin Name	Connector	Pin	I/O
CAN_H	J281	1	I/O
CAN_L	J281	2	I/O
CAN_TERM_1	J281	3	--
CAN_TERM_2	J281	4	--

E.8.5 ID STRAP

The ID Strap inputs are used to configure the GSA 28 as a roll, roll trim, pitch, pitch trim, or yaw servo by installing a jumper wire or not installing a jumper wire per the following:

Roll Servo: No jumper wire installed

Pitch Servo: Jumper wire installed from pin 5 to pin 8

Yaw Servo: Jumper wire installed from pin 6 to pin 7

Roll Trim: Jumper wire installed from pin 5 to pin 8 and from pin 6 to 7

Pitch Trim: Jumper wire installed from pin 7 to pin 8

Pin Name	Connector	Pin	I/O
ID_STRAP_1	J281	5	In
ID_STRAP_2	J281	6	In
ID_STRAP_3/(RS-232 TX for Roll Servo Only)	J281	7	In
ID_STRAP_4/(RS-232 RX for Roll Servo Only)	J281	8	In

E.8.6 RS-232

Pins 7 and 8 (TX and RX) connect to the GMC 30X RS232 channel 2 on the ROLL SERVO ONLY.

Pin Name	Connector	Pin	I/O
ID_STRAP_3/(RS-232 TX for Roll Servo Only)	J281	7	Out
ID_STRAP_4/(RS-232 RX for Roll Servo Only)	J281	8	In

E.8.7 Trim

The trim inputs should connect to the panel trim switch or pilot/copilot trim switch mixer. The trim outputs should connect to the trim motor. Maximum output current of the trim outputs is 1A for 12V trim motors and 0.5A for 24V trim motors.

If the GSA 28 is not powered, a fail-safe feature causes the trim inputs to connect directly to the trim outputs. If trim motor control is disabled for a GSA 28 servo that is powered (the fail safe relay is open), the trim motor output is driven by the servo at full output level (12V or 24V) with no speed scheduling. If the GSA 28 servo is powered, trim motor control is enabled and configured for speed scheduling, the servo drives the trim outputs based on the trim inputs and aircraft speed. If the servo is powered with the autopilot engaged and trim motor control is enabled, the servo has full control (auto-trim) of the trim outputs.

A removal adapter (GPN 011-03158-00) is provided (with each GSA 28 connector kit) that can be used when a GSA 28 is removed. The adapter keeps that node on the CAN bus in the same state as when the servo was connected (either terminated or un-terminated). The adapter also allows trim signals to pass through when the servo is removed.

Pn Name	Connector	Pin	I/O
TRIM_IN_1	J281	11	In
TRIM_IN_2	J281	12	In
TRIM_OUT_1	J281	13	Out
TRIM_OUT_2	J281	14	Out

GARMIN  **®**