

Figure 2 Mono installation of the headset

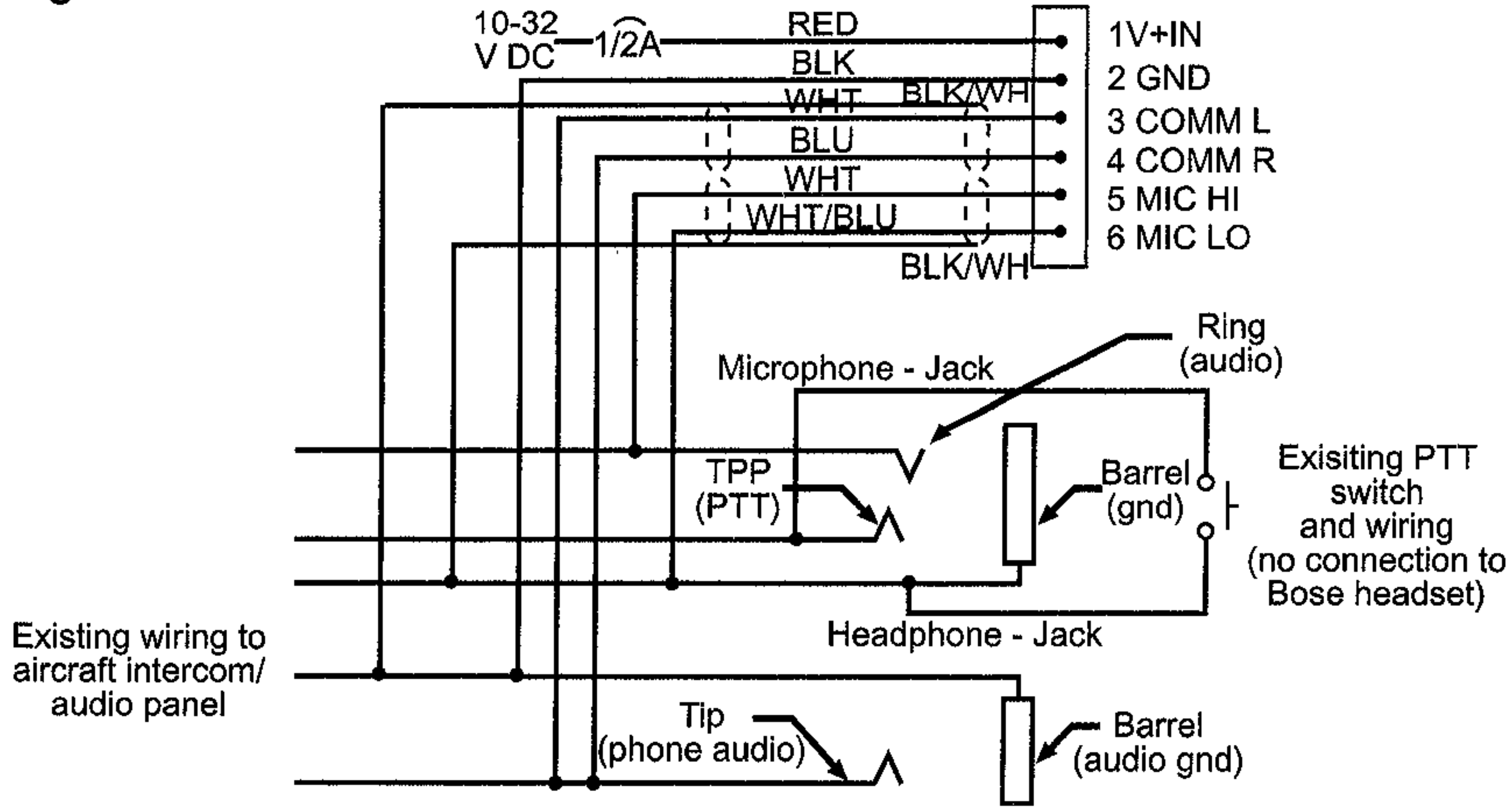

Figure 3 Installation to existing aircraft stereo jacks

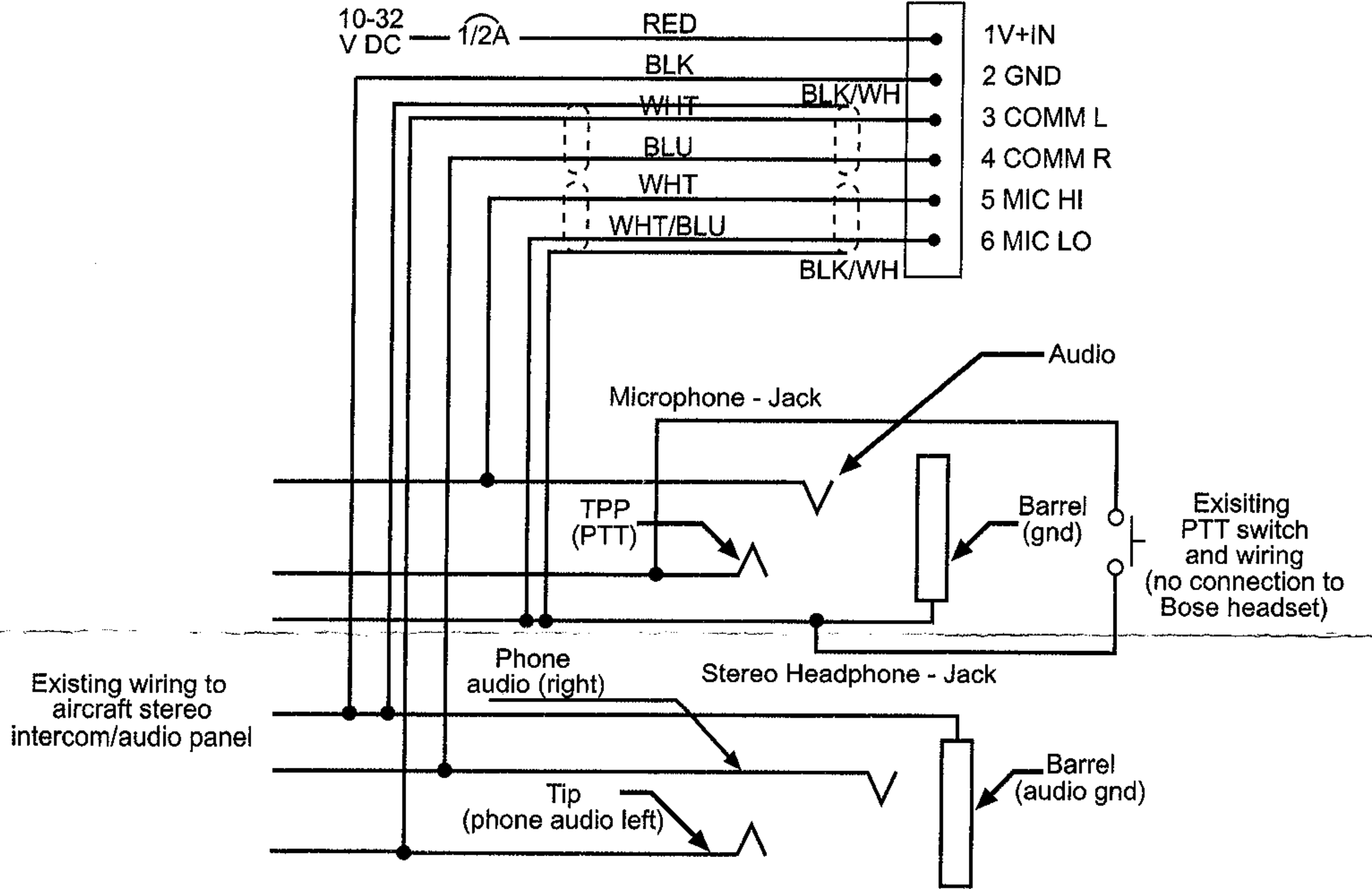
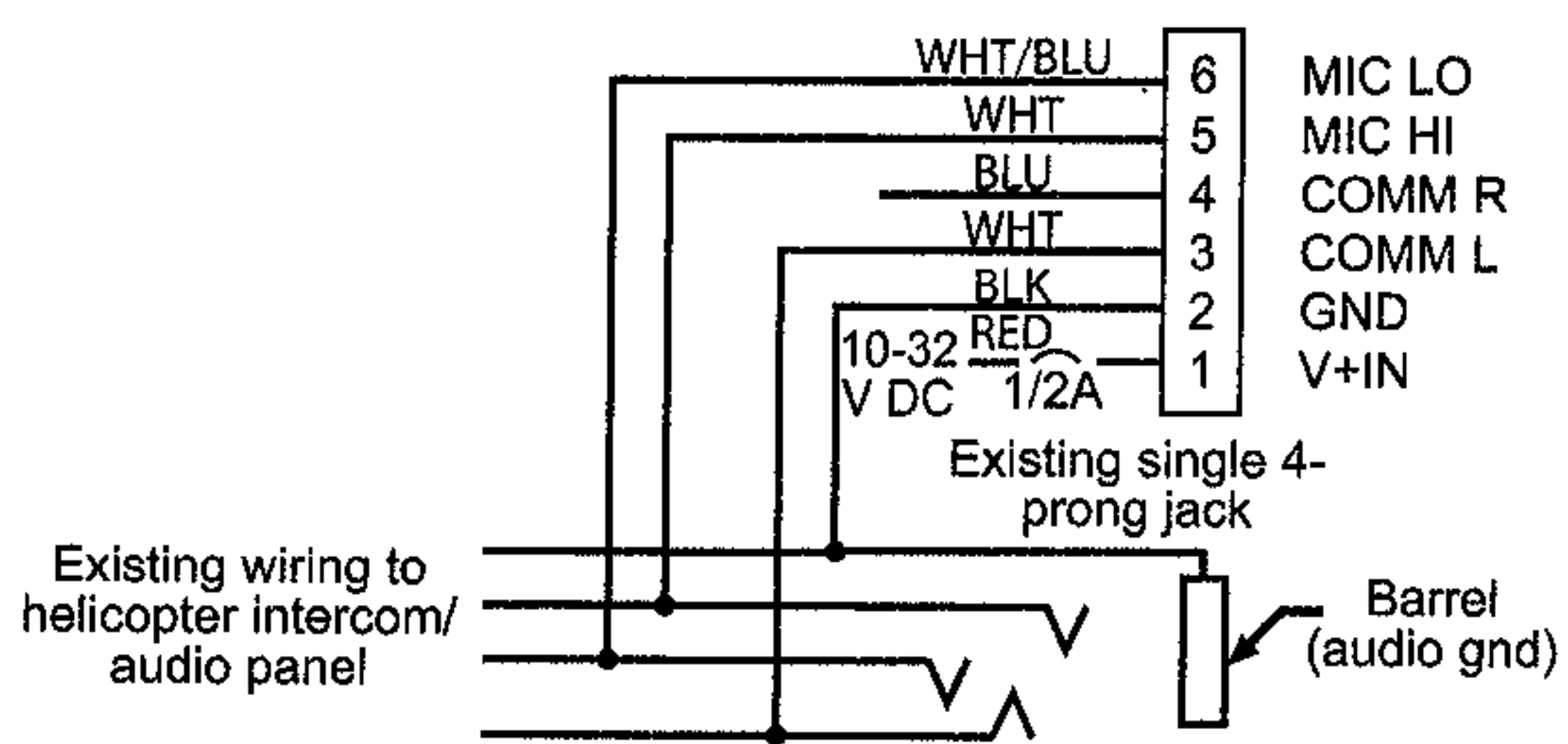

Figure 4 Installation to existing helicopter single jack



Instructions for continued airworthiness

Bose recommends following the General Care and Maintenance instructions in the Owner's Guide. With normal use, items such as windscreens and ear cushions will require periodic replacement. If cleaning or replacement of these items is needed, follow the recommendations in the Owner's Guide. All other care and maintenance in and out of the warranty period must be performed by Bose or an authorized dealer.

For Bose Series I users who are upgrading, a cover plate is available to seamlessly install this wire harness. Ask customer service for Bose material number 019585.

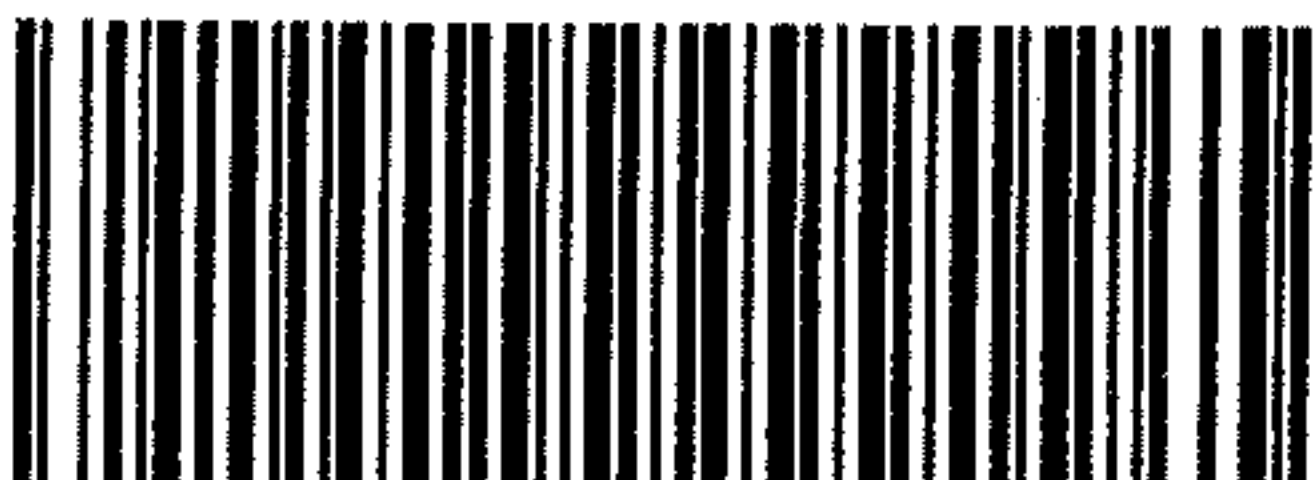

©2015 Bose Corporation, The Mountain, Framingham, MA 01701-9168 USA
AM323160 Rev. 02

Bose® Aviation Headset Aircraft Panel Connector Installation Instructions

For permanent installation of the headset, the harness (material number 323172-0010) is installed into the aircraft. The 3-foot wiring harness includes a self-latching, precision designed, quick-connector for panel mounting in the aircraft. The connector is mechanically keyed to ensure proper mating. To order additional harnesses, call Bose at 1-800-242-9008.

Note: The aircraft panel connector must be installed and documented by personnel qualified to perform this type of avionics installation into the aircraft being used. Consult your local FAA office or aviation authorities to determine the appropriate documentation required.

The Bose connector (material number 323172-0010) is TSO approved (C-57a and C-139) together with the Bose A20™ Aviation Headset, the Bose Series II Aviation Headset, and the Bose Aviation Headset X.

Installing the aircraft panel connector

Audio and microphone wires should be connected to the back of the existing microphone and headphone jacks, leaving existing jacks intact for use with conventional headsets. This is usually the fastest installation method (see Figures 1 – 4 for reference). Audio shields should be connected to ground at the existing jack.

(Caution: Use of two headsets wired in parallel is not advised. This may result in reduced performance.)

FIGURE 1

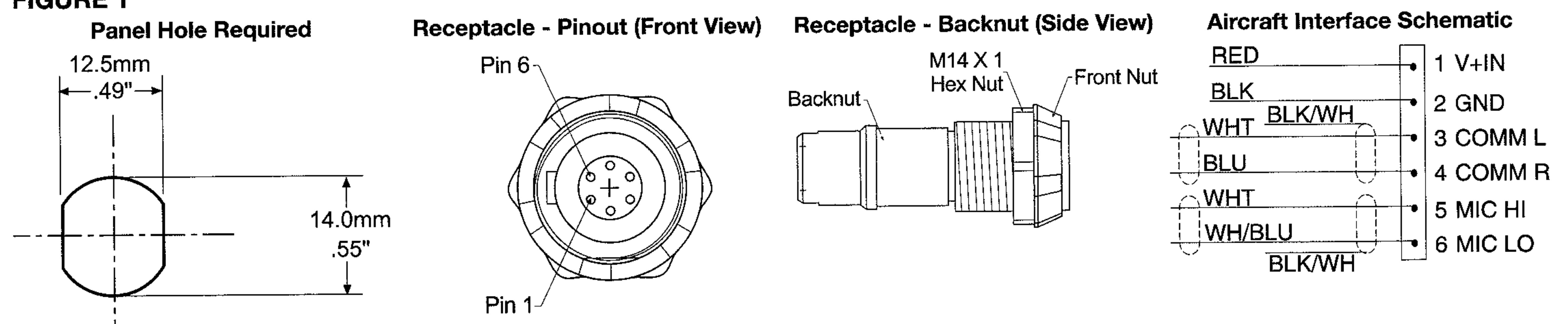

The pinout for the installed connector is:

Pin	Wire color	Description
1	Red	Headset power (10-32 VDC). Use a 1/4 amp fuse or a 1/2 amp circuit breaker.
2	Black	System ground. Connect to the existing audio ground.
3	White	Phone communication – L
4	Blue	Phone communication – R
5	White	Microphone/Hi-audio. Connect to the portion of the existing microphone jack that corresponds to the ring position of a headset microphone plug. Do not connect to the tip (PTT) segment.
6	White/Blue	Microphone/Lo-audio. Connect to the portion of the existing microphone jack that corresponds to the barrel position of a headset microphone plug.
Comm Shield	Black/White	Shield from Comm 1 and Comm 2 wire pair.
Mic Shield	Black/White	Shield from Mic Hi and Mic Lo wire pair.

Notes

- For use with a stereo intercom, connect the left and right channels to their respective positions. If your intercom provides a monaural audio signal, connect pins 3 & 4 together to the tip of the existing phone jack.
- Do not use excessive force or bend the installed connector. This may damage or break internal solder joints.
- If the boom microphone works on radio transmit but not through the intercom, check pin 6. It may be incorrectly wired to the PTT segment of the microphone jack.
- The wires connecting pins 3 & 4 and pins 5 & 6 are shielded, twisted pairs with a shield termination exiting with a black/white wire for each pair. Connect shields to existing audio wiring shields or to audio ground, if existing wiring is not shielded.
- The Bose aircraft panel connector cannot be installed to an audio system using transformer-coupled audio outputs. Call the Bose Aviation Headset Department for details: 800-287-0611.
- Connecting power directly to pins 5 or 6 will result in damage to the microphone.
- The wire gauge is 22 AWG.
- If backnut has been removed, make sure a thread lock is applied and torque backnut to 3 in•lbs.

Adhesives approved for use with this connector are:

- VTCS-6 Vibratite (acrylic resin)
- Three Bond 1401 (polyvinyl acetate resin)
- Scotch Weld DP190 (epoxy adhesive)
- Do not let cyanoacrylate-based adhesives, flux remover, or other caustic compounds contact the connector body. These chemicals cause irreparable damage to the connector.
- Acrylic or vinyl thread lock resins will not effect plastic.